

SAFE-T-MANUAL

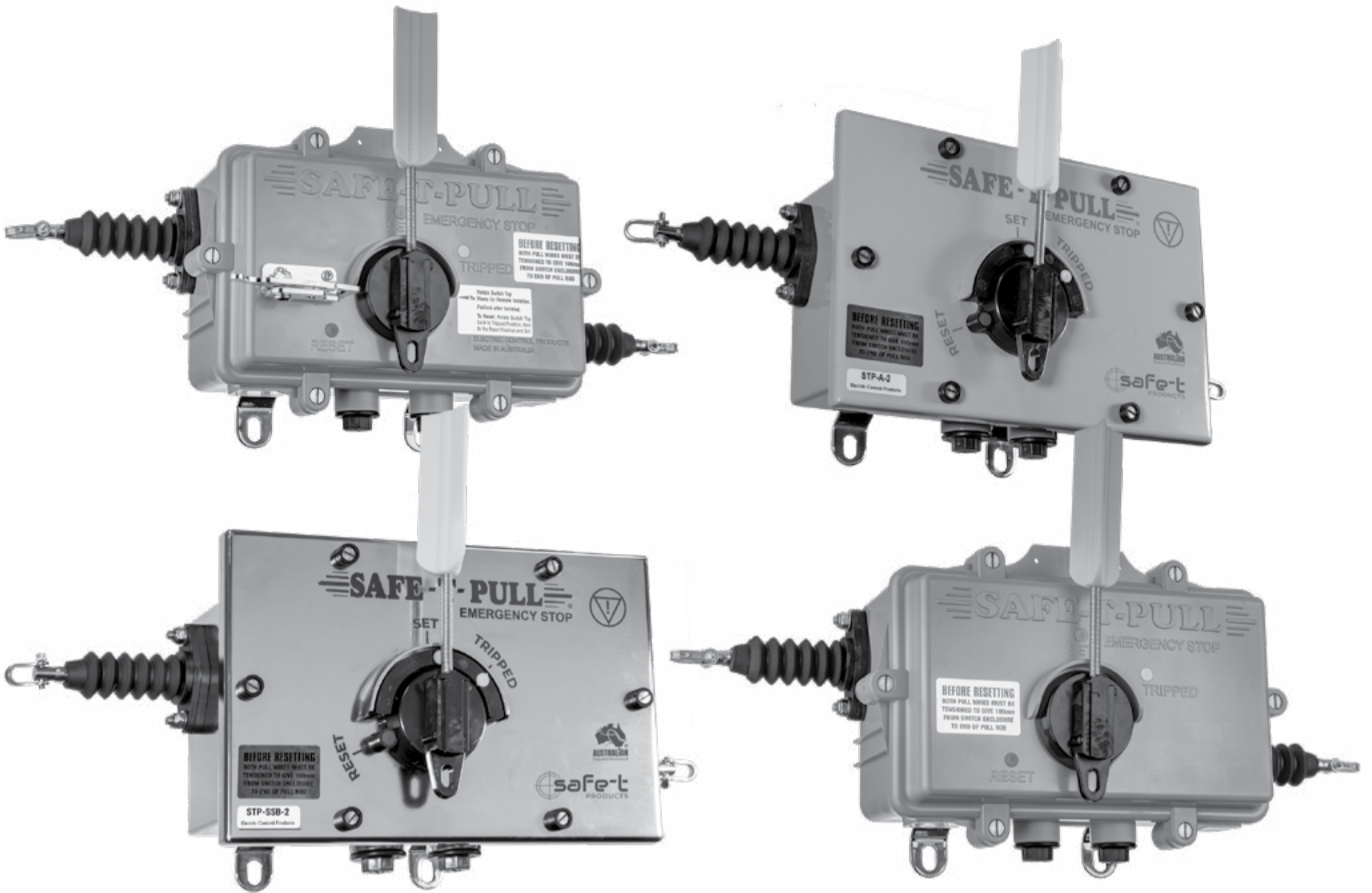

SIL



Scan or tap the QR code to access the full technical documentation on our website.

EMERGENCY STOP SAFETY SYSTEM

INSTALLATION, DESIGN, TESTING, SETTING
INSTRUCTION AND TECHNICAL DOCUMENTATION

PLEASE VISIT OUR YOUTUBE CHANEL OR WEBSITE
FOR MORE INFORMATION



www.safe-t-products.com.au



INDEX

- 3** **PULL CORD TRADITIONAL INSTALLATION (STL-10-SS) 316**
- 4** **STAINLESS STEEL PULL CORD QUICK INSTALLATION (STL-10-SS) 316**
- 5** **VECTRAN PULL CORD QUICK INSTALLATION (STL-10-V)**
- 6** **STP NON TENSION SETUP**
- 7** **RESETTING DIAGRAMS**
- 8** **BULK HANDLING MATERIAL CONVEYORS: LOCATION OF EMERGENCY STOPS**
- 9** **LOCATION OF PULL CORD**
- 10** **STP-AS000 FUNCTIONAL DRAWING DIMENSIONS**
- 11** **STG-FGK FIRST GUIDE SUPPORTS - SAFE-T-PULL**
- 12** **MICRO SWITCH CIRCUIT DIAGRAM (STP-P-2* STP-A-2* STP-SSB-2*)**
- 13** **MICRO SWITCH CIRCUIT DIAGRAM (STP-P-4* STP-A-4* STP-SSB-4*)**
- 14** **MICRO SWITCH CIRCUIT DIAGRAM - STROBE LIGHT (STP-P-2-S* STP-A-2-S* STP-SSB-2-S*)**
- 15** **MICRO SWITCH CIRCUIT DIAGRAM - STROBE LIGHT (STP-P-4-S* STP-A-4-S* STP-SSB-4-S*)**
- 16** **DIRECT OPENING ACTION - MICRO SWITCHES**
- 17** **STANDARDS/POLICY**
 - STANDARD
 - WORKSHOP TESTED
 - MODIFICATION OF DEVICE
 - RETURNS POLICY/RE-STOCKING
 - WARRANTY
 - PRODUCT LIFE EXPECTANCY
 - TECHNICAL SUPPORT
 - OBSOLETE PRODUCTS
 - LOCATION OF EMERGENCY STOPS
 - 6 MONTHLY MAINTENANCE PROCEDURE
 - PRODUCT SURFACE TREATMENT
- 19** **SAFE-T-SPRING**
- 19** **TEST 1**
- 20** **TEST 2**
- 23** **DEVICE OVERLAY DIMENSION DRAWING STP-P, STP-A, STP-SSB**
- 24** **REMOTE ISOLATION DEVICE (STP-P-2-RI)**
- 25** **HOOK POLE ASSEMBLY**
- 26** **MS PULL CORD ASSEMBLY**
- 27** **REPLACEMENT LID ALLOCATION STICKERS SAFE-T-PULL STAINLESS STEEL**
- 27** **REPLACEMENT LID ALLOCATION STICKERS SAFE-T-PULL PC/PBT PLASTIC**
- 28** **REPLACEMENT LID ALLOCATION STICKERS SAFE-T-PULL STAINLESS STEEL REMOTE ISOLATION**
- 28** **REPLACEMENT LID ALLOCATION STICKERS SAFE-T-PULL PC/PBT PLASTIC REMOTE ISOLATION**

SAFE-T-PULL

STP-P-* STP-A-* STP-SSB-*

STAINLESS STEEL PULL CORD QUICK INSTALLATION (STL-10-SS) 316

RECOMMENDED

(FASTER THAN TRADITIONAL INSTALLATION)



Scan the QR Code for further details regarding lanyard and termination installation guidelines.

NOTE: Lanyards are to be fitted in front of removable guards, nip and shear points that are accessible on all bulk handling material conveyors and not to be replacements for guards.

YELLOW INDICATION FLAG: STP-F
The Indication Flag should be fitted when there is more than one device used on the conveyor as noted in AS4024.3610:2015 Clause 2.10.6.2 (e) **NOTE:**

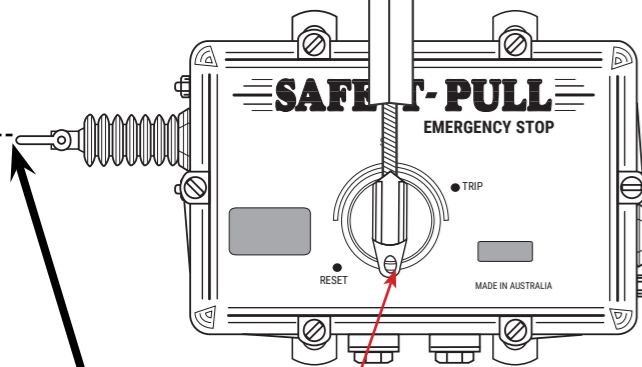

Use the Same Set Up on the Other Side for Dual Direction Device.

To reset the device via the device top only takes approximately 1Nm. If a higher torque is felt, check device set point. IEC 60947-5-5 Clause 7.7.4

FIRST SUPPORT
300mm MINIMUM
1000mm MAXIMUM

ENSURE CLEARANCE FOR PULL CORD FIXINGS TO FIRST PULL CORD SUPPORT WHEN PULL CORD IS FULLY ACTIVATED.
See dimension drawing below for set point

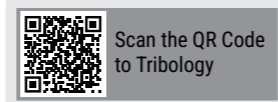

Scan the QR Code to Tribology

NOTE: FIRST SUPPORT MUST BE ON CENTRE LINE OF DEVICE PULL ROD
PULL CORD SUPPORT
STG-200-SS or STG-350-SS
Guide (Polypropylene) (304) M10 Rod (304)
PULL CORD SHOULD BE AS STRAIGHT AS POSSIBLE TO REDUCE FRICTION AND THEY SHALL BE CLEAR OF OBSTRUCTIONS, CLEARLY IDENTIFIABLE, CLEARLY VISIBLE AND READILY ACCESSIBLE.

OTHER SUPPORTS

3000mm RECOMMENDED
3000mm RECOMMENDED

MAX. DISTANCE RECOMMENDATION:
BOTH SIDES OF THE DEVICE 100m - STRAIGHT CONVEYOR
80m - INCLINE CONVEYOR (OVER 5°)

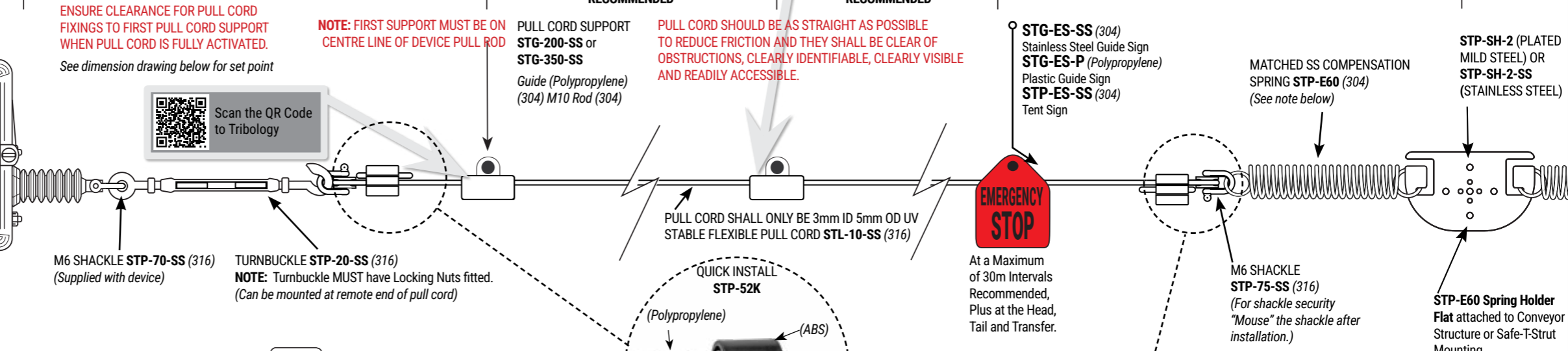

M6 SHACKLE STP-70-SS (316) (Supplied with device)
TURNBUCKLE STP-20-SS (316) **NOTE:** Turnbuckle MUST have Locking Nuts fitted. (Can be mounted at remote end of pull cord)



EMERGENCY STOP
At a Maximum of 30m Intervals Recommended, Plus at the Head, Tail and Transfer.

STG-ES-SS (304) Stainless Steel Guide Sign
STG-ES-P (Polypropylene) Plastic Guide Sign
STP-ES-SS (304) Tent Sign
MATCHED SS COMPENSATION SPRING STP-E60 (304) (See note below)
STP-SH-2 (PLATED MILD STEEL) OR STP-SH-2-SS (STAINLESS STEEL)
STP-E60 Spring Holder Flat attached to Conveyor Structure or Safe-T-Strut Mounting

NOTE: After actuation and before resetting, the machinery shall be inspected along the whole length of the pull cord in order to detect the reason for activation. AS4024.1604 Clause 4.54

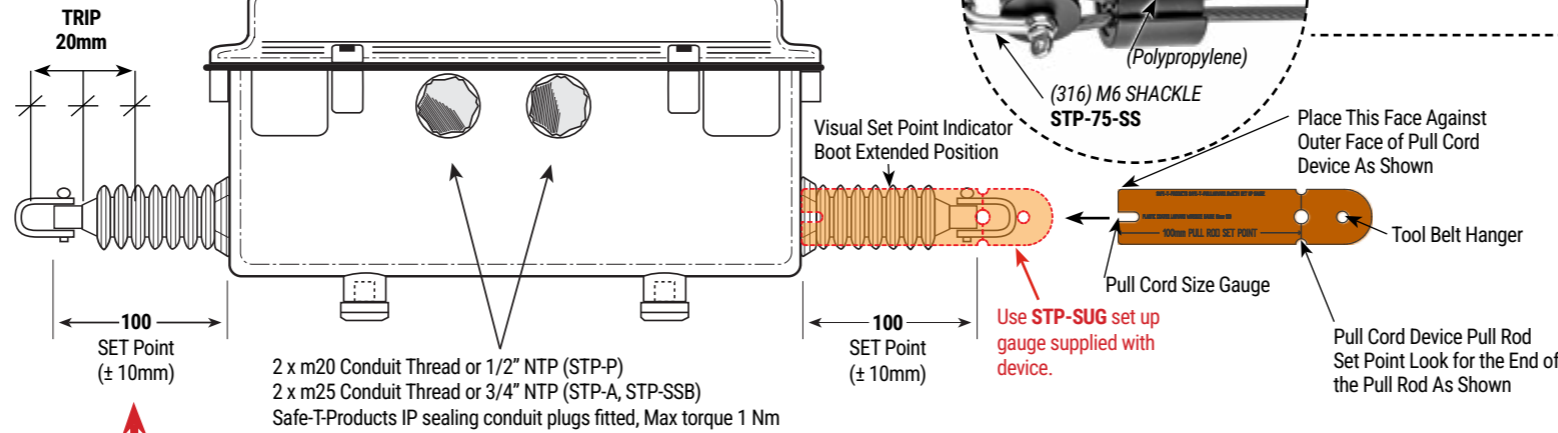

DEVICE CANNOT BE RESET UNTIL BOTH PULL CORDS ARE CORRECTLY TENSIONED TO THE SET POSITION
ie. 100mm from pull rod end to device body.
The 100mm set point on the Safe-T-Pull is the optimal position. At this setting, the device achieved the best balance between sensitivity and reliability during operation, while still reliably resetting when the rods are pulled within the 90mm to 110mm range.

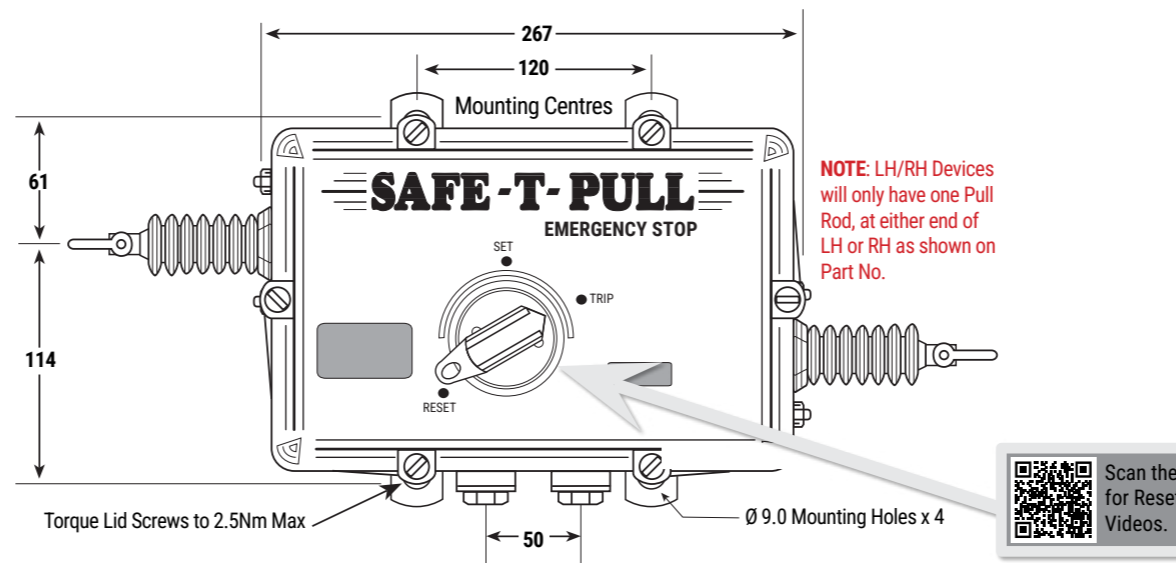

For further installation requirements refer to AS/NZS 4024-1-2014 Series: Safety of Machinery.

NOTE: To comply with the safety critical functions in AS/NZS 4024.3610 - 2015 Section 2.10.5 Emergency Stop. The locations of pull cords, components and elements to achieve the emergency stop function, person - on - conveyor stop, general requirements and pull cord design must all be reviewed before installation. In reviewing this, a balance matched compensation spring must be fitted to the remote ends of the taut pull cord system so that the system may work in all directions correctly. The Safe-T-Pull device has its own balance matched compensation spring that will only work on this Safe-T-Products device.

NOTE: These springs are tagged with a stainless steel label noting the compliance. Other branded devices must have their own compensation spring used. They should be balance matched to the internal spring system so the pull cord system is still functioning as a safety critical system and meets the requirements of the standards.

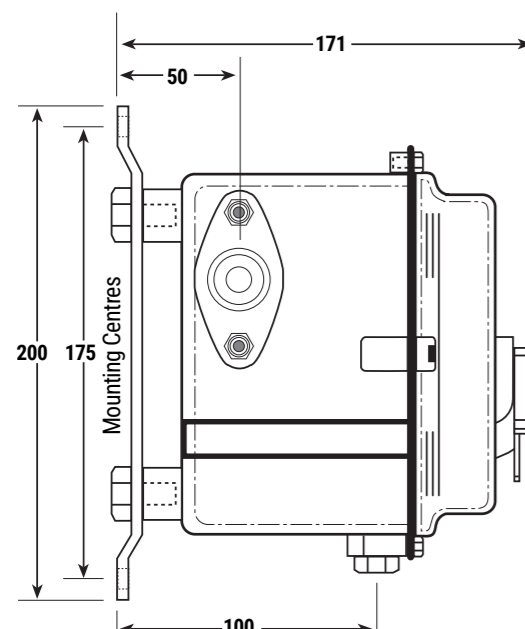

TRIP 20mm
SET Point (± 10mm)
100
171
50
200
175
Mounting Centres
100

2 x m20 Conduit Thread or 1/2" NTP (STP-P)
2 x m25 Conduit Thread or 3/4" NTP (STP-A, STP-SSB)
Safe-T-Products IP sealing conduit plugs fitted, Max torque 1 Nm

NOTE: LH/RH Devices will only have one Pull Rod, at either end of LH or RH as shown on Part No.

Torque Lid Screws to 2.5Nm Max
50
Ø 9.0 Mounting Holes x 4

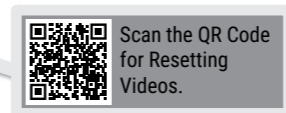

Scan the QR Code for Resetting Videos.



SAFE-T-PULL

STP-P-2-NT & STP-P-4-NT

STP NON TENSION SETUP

(MUST USE ELECTRIC COMMUNICATION CABLE - DEVICE TO DEVICE)

NOTE: Lanyards are to be fitted in front of removable guards, nip and shear points that are accessible on all bulk handling material conveyors and not to be replacements for guards.

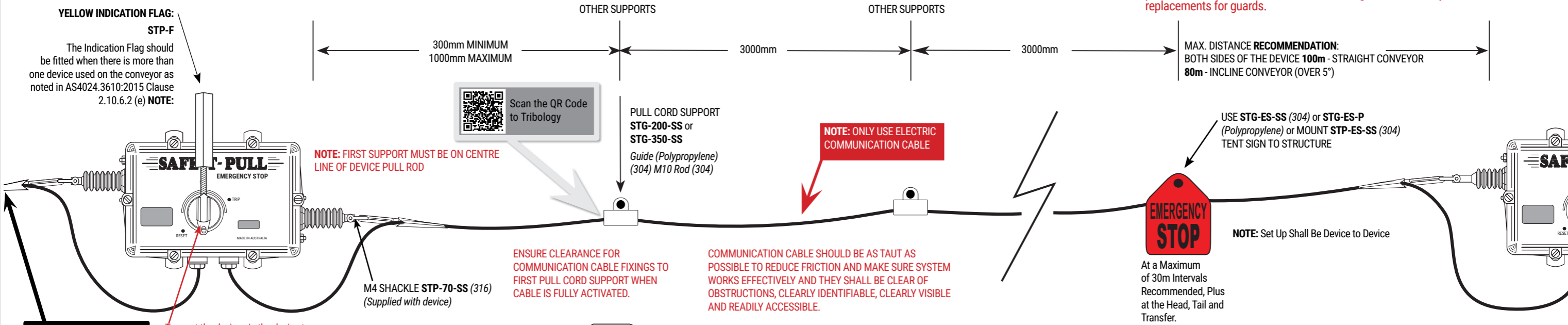

Use the Same Set Up on the Other Side for Dual Direction Device.

To reset the device via the device top only takes approximately 1Nm. If a higher torque is felt, check device set point. IEC 60947-5-5 Clause 7.7.4

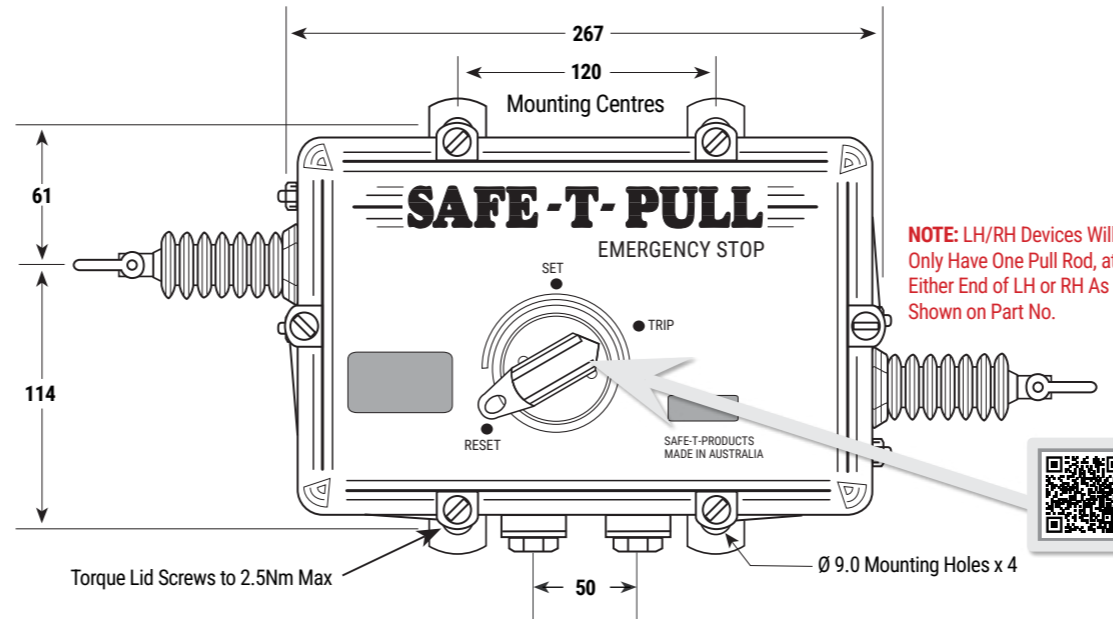
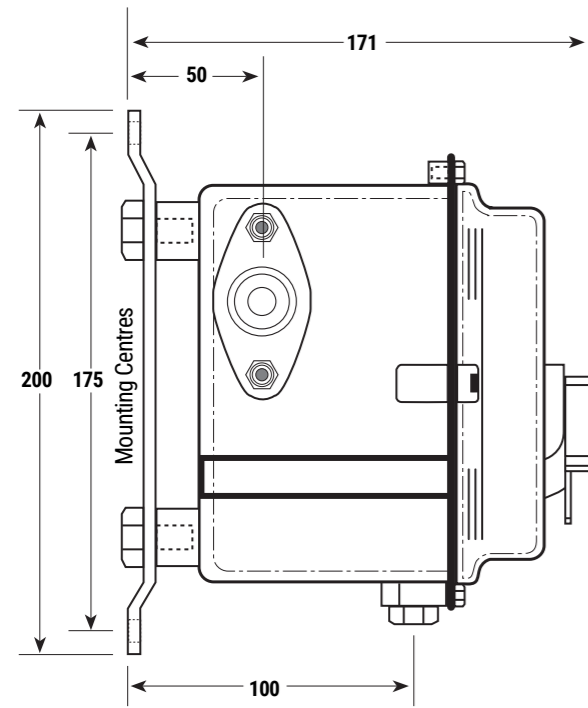
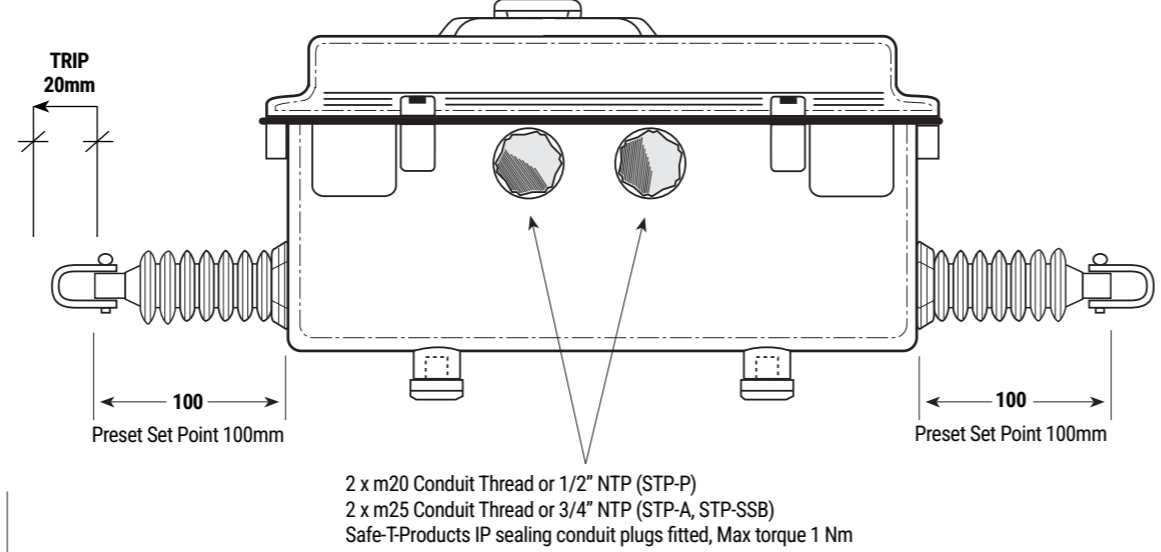

For further installation requirements refer to AS/NZS 4024-1-2014 Series: Safety of Machinery.

NOTE: To comply with the safety critical functions in AS/NZS 4024.3610 - 2015 Section 2.10.5 Emergency Stop. The locations of pull cords, components and elements to achieve the emergency stop function, person - on - conveyor stop, general requirements and pull cord design must all be reviewed before installation.

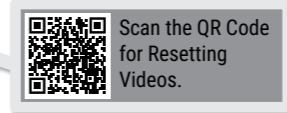

RESETTING DIAGRAMS

TENSION DEVICE RESETTING

TENSION DEVICE DUAL
MUST USE PULL CORD
DUAL SIDED OPERATION TYPE

PULL OUT RODS & KEEP AT 100mm, THEN RESET VIA DIAL. ECPGS-027

Scan QR Code for reset & trip details ↑

STP-P, -A, -SSB

TENSION DEVICE RIGHT HAND
MUST USE PULL CORD
SINGLE SIDED OPERATION TYPE

PULL OUT ROD & KEEP AT 100mm, THEN RESET VIA DIAL. ECPGS-027-A

Scan QR Code for reset & trip details ↑

STP-P-RH, -RH, -A-RH, -SSB-RH

TENSION DEVICE LEFT HAND
MUST USE PULL CORD
SINGLE SIDED OPERATION TYPE

PULL OUT ROD & KEEP AT 100mm, THEN RESET VIA DIAL. ECPGS-027-B

Scan QR Code for reset & trip details ↑

STP-P-LH, -LH, -A-LH, -SSB-LH

SLACK/NON TENSION DEVICE RESETTING

SLACK/NON TENSION DEVICE DUAL
MUST USE COMMUNICATION CABLE
DUAL SIDED OPERATION TYPE

RODS IN PRESET POSITION ECPGS-028

Scan QR Code for reset & trip details ↑

STP-P-NT, -NT, -A-NT, -SSB-NT

SLACK/NON TENSION DEVICE RIGHT
MUST USE COMMUNICATION CABLE
RIGHT HAND OPERATION TYPE

ROD IN PRESET POSITION ECPGS-028-A

Scan QR Code for reset & trip details ↑

STP-P-NT-RH, -NT-RH, -A-NT-RH, -SSB-NT-RH

SLACK/NON TENSION DEVICE LEFT
MUST USE COMMUNICATION CABLE
LEFT HAND OPERATION TYPE

ROD IN PRESET POSITION ECPGS-028-B

Scan QR Code for reset & trip details ↑

STP-P-NT-LH, -NT-LH, -A-NT-LH, -SSB-NT-LH

SAFE-T-PULL LID INSTALLATION OR REPLACEMENT DETAILS

SAFE-T-PULL LID

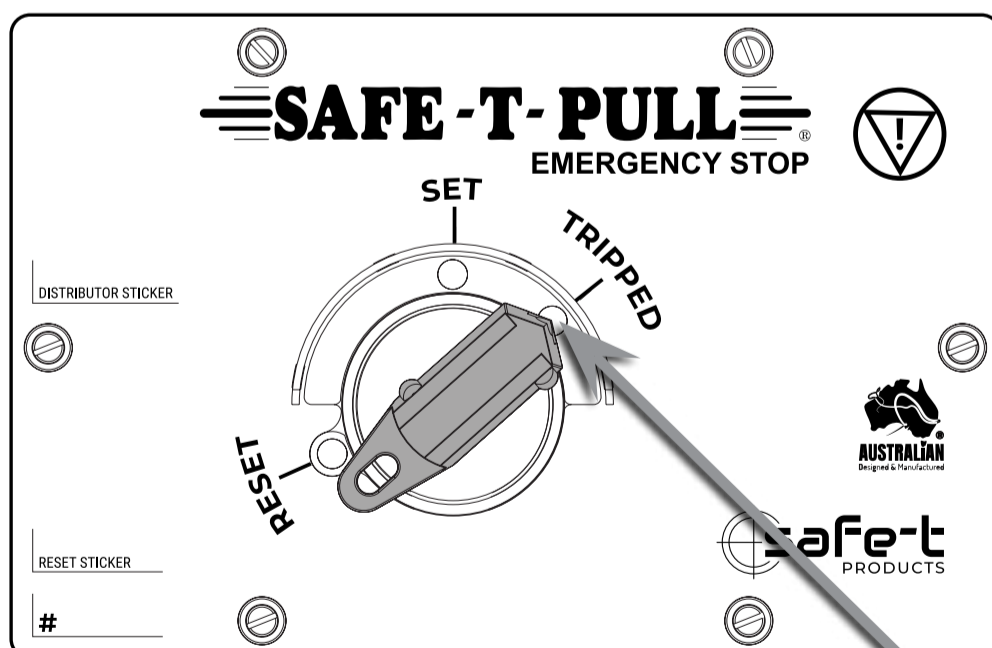

SAFE-T-PULL UNDERNEATH SWITCH PLATE

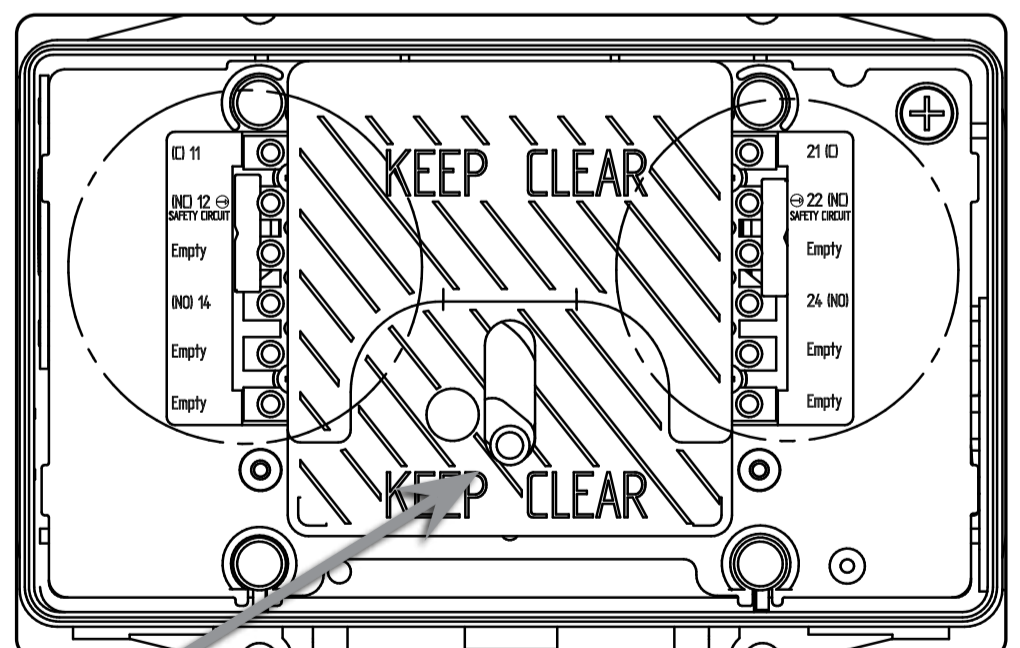

The Safe-T-Pull device must be in the tripped position before installing the lid. The lid is designed to serve as both an indicator and a safety function mode. It is engineered so that if the lid fails or is installed incorrectly, it will not affect the overall safety function of the device.

BULK HANDLING MATERIAL CONVEYORS: LOCATION OF EMERGENCY STOPS

AS/NZS 4024.3611

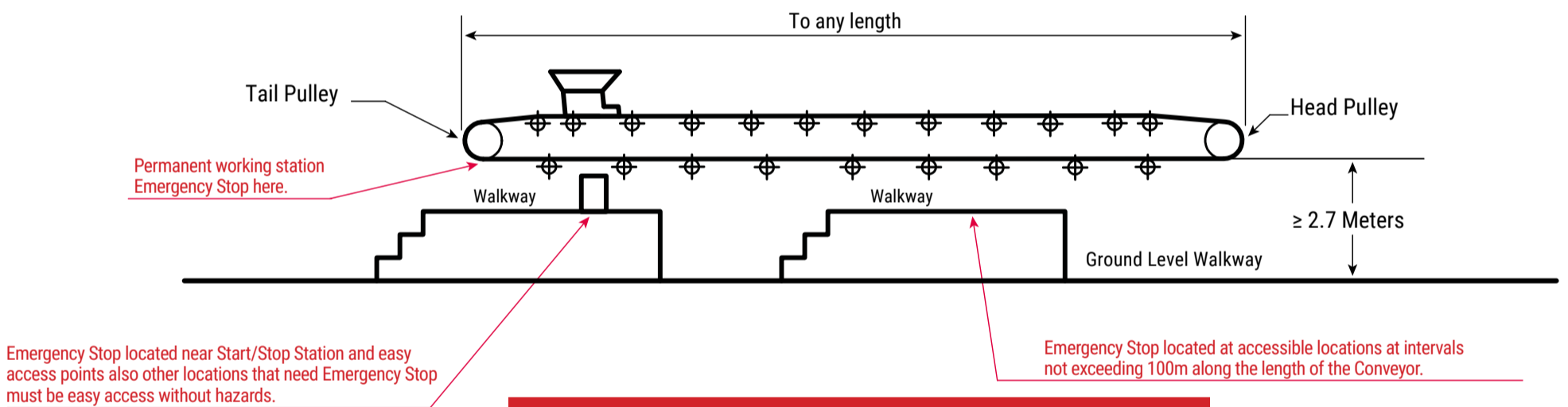
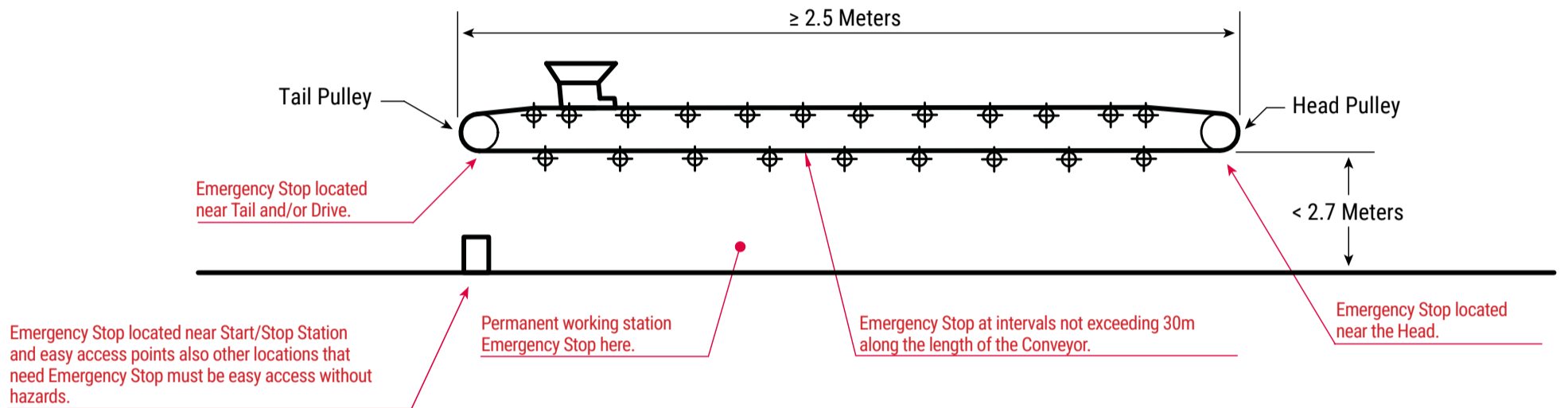
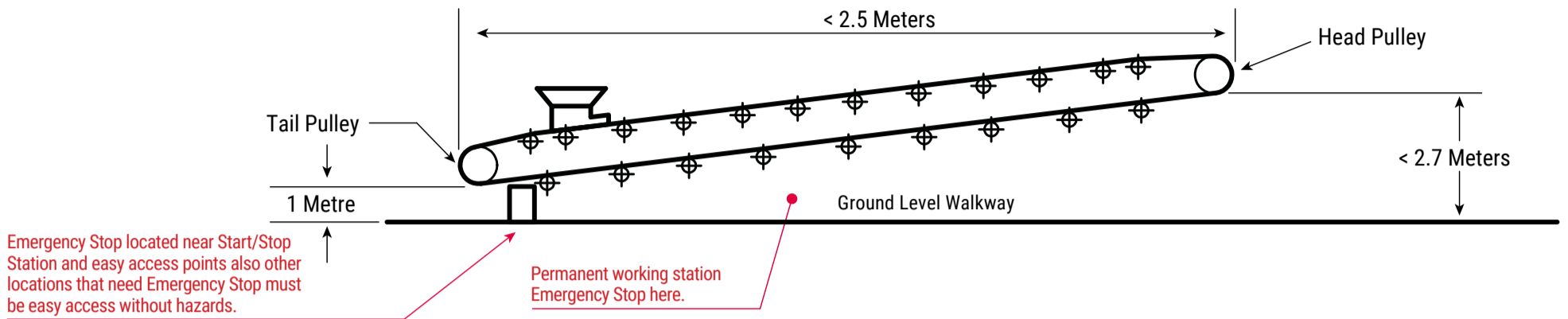

NOTE: Consideration shall be given for the provision of an emergency stop at the take-up where the take-up is on another level or remote from the main drive.

DEFLECTIONS - PULL CORD SETUP

NOTE: Keep deflections to a minimum angle and as least as possible.

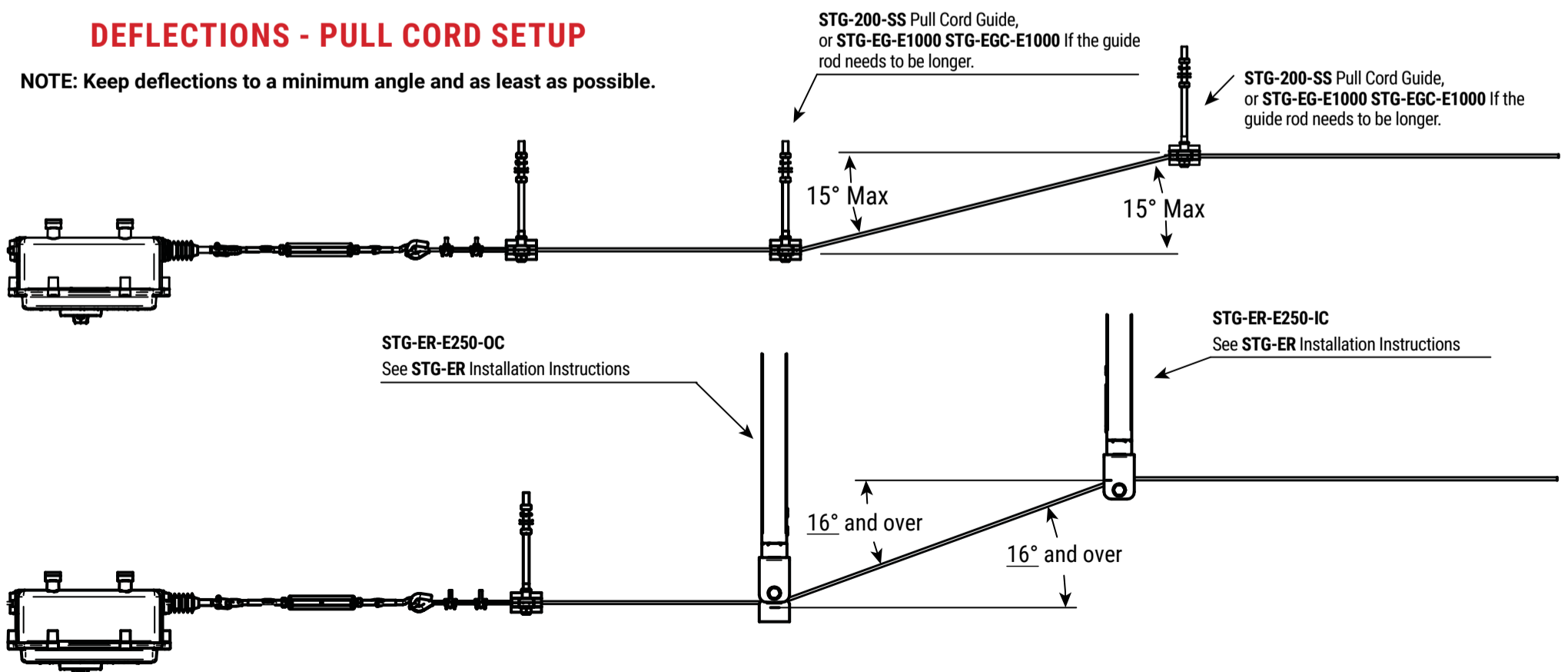

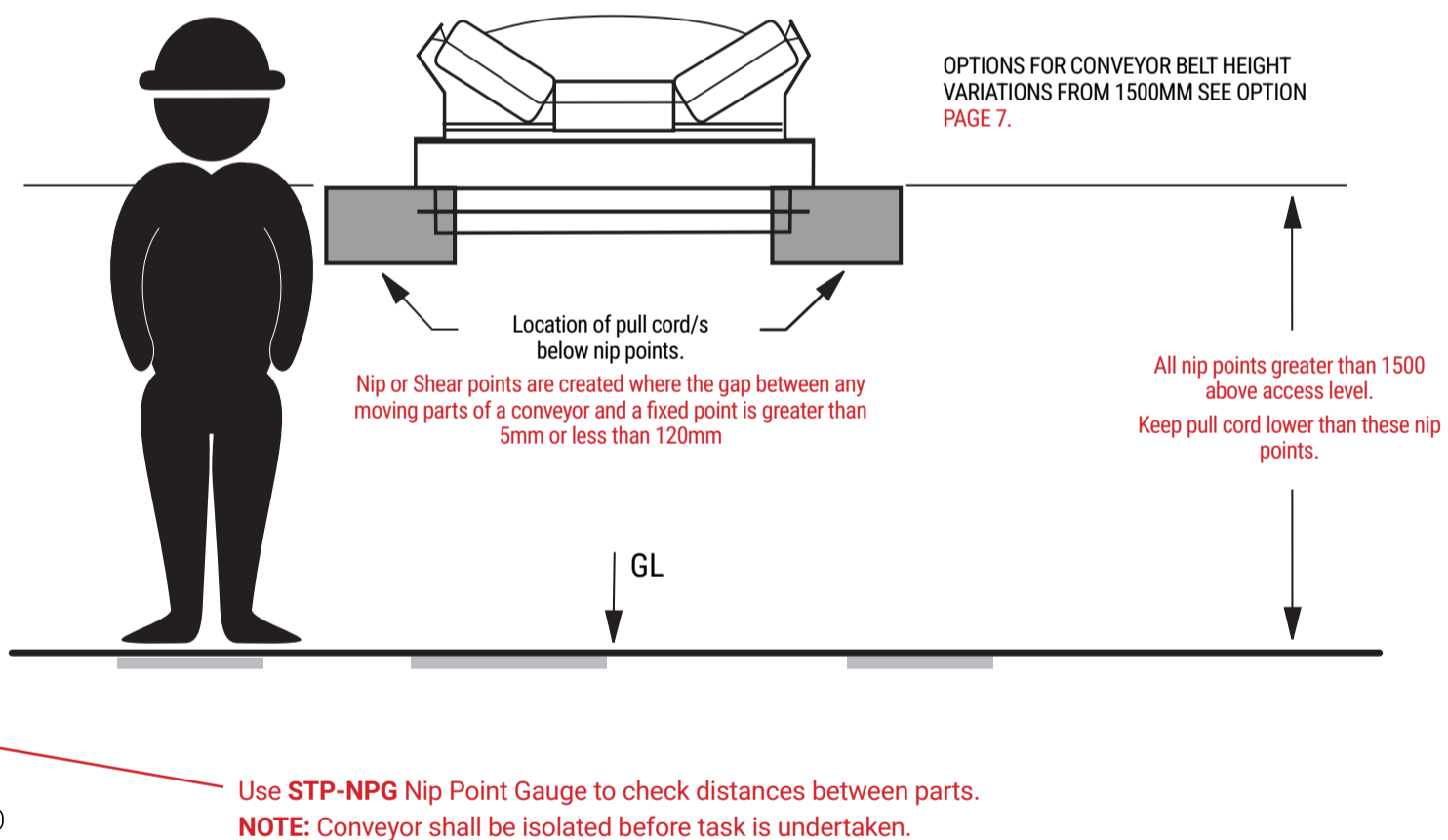
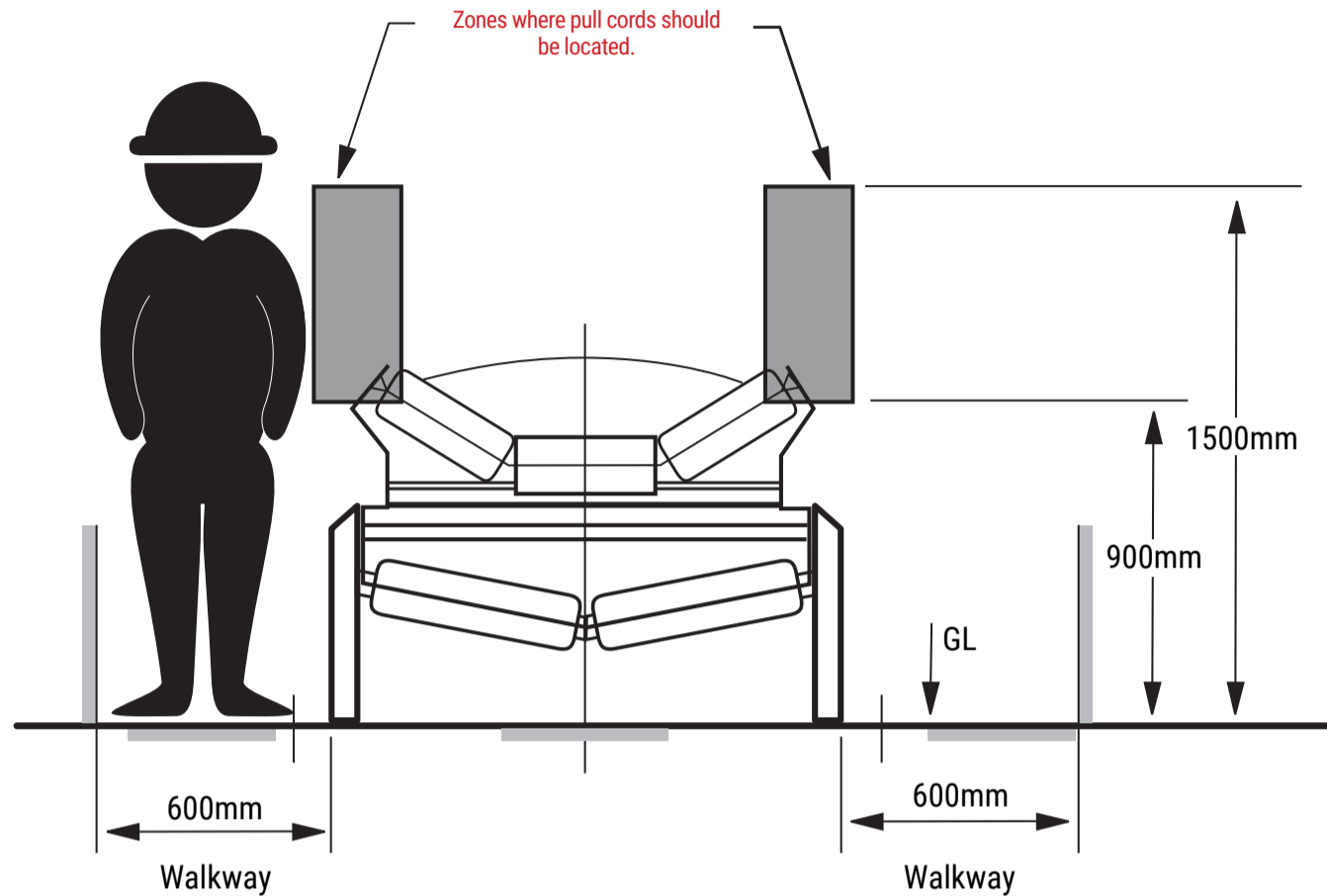

LOCATIONS OF PULL CORDS

The design risk assessment shall determine the most favourable location for the pull cord systems location.

Where practicable, pull cords should be in such a manner that they are, clearly visible, adding signs or colour of pull cords can help. Readily accessible for any personnel that potentially may become trapped in a danger area or any personnel that may be nearby. Outside any readily removable guard and external to the vertical line of any nip or shear point. They should be no further than 1m from the nip or shear point.

At least 900mm above the access floor. Should be no more than 1500mm above the access floor. Where required to be higher than 1500mm, the pull cord system should be located lower than the nip or shear points.

Also, the consideration of the potential for a person to inadvertently be on a moving conveyor, the severity of injury to a person due to this event and whether a risk control needs to be in place.

Safe-T-Products recommends the "Collide-Safe" Man-On-Belt device for this application.

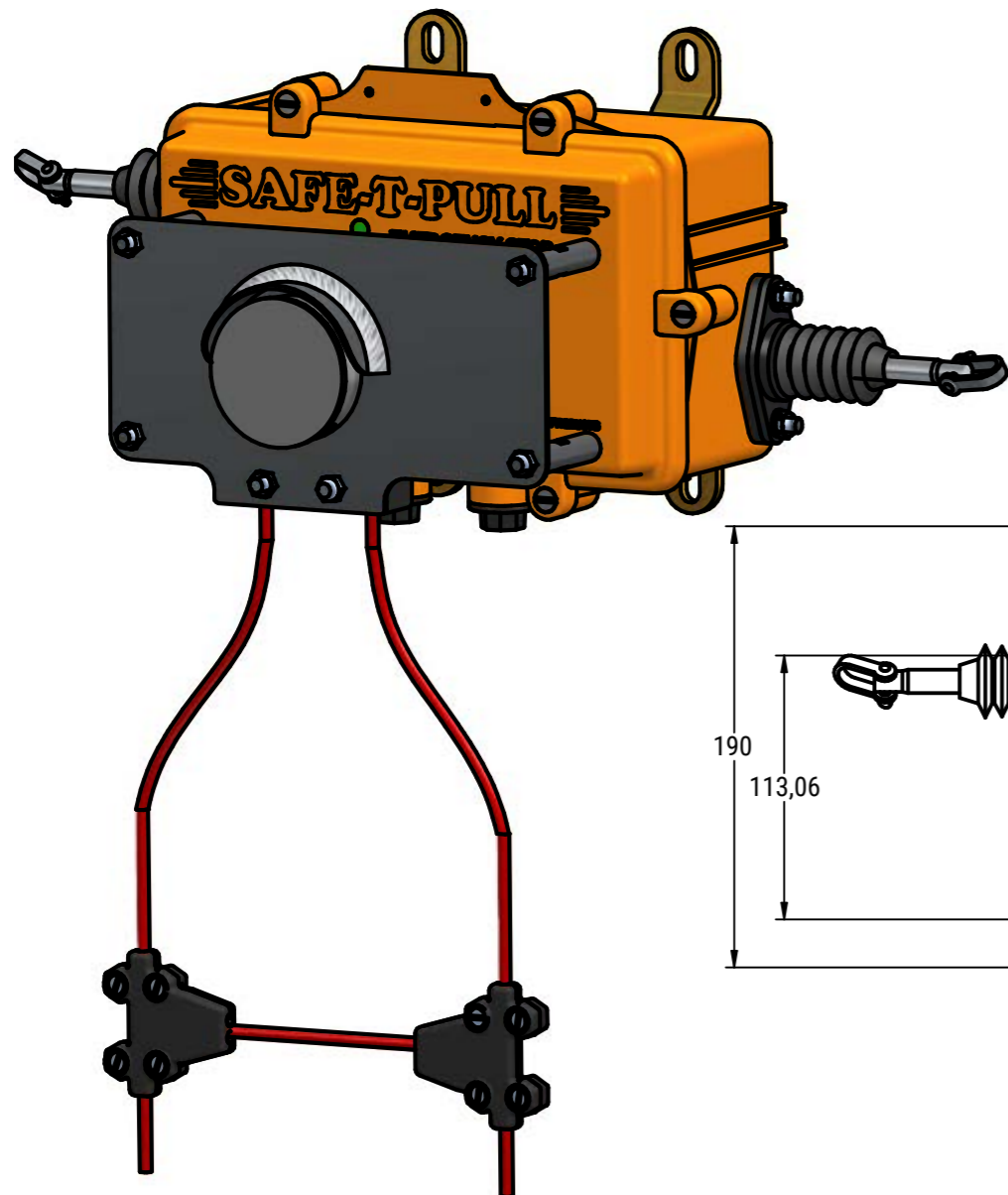

ADJUSTABLE LENGTH PULL CORDS

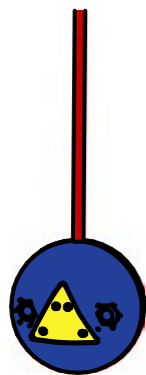

RESET BALL

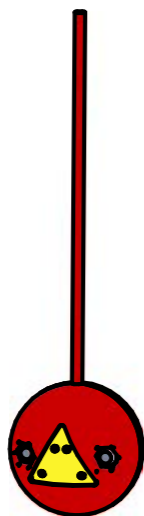

TRIP BALL

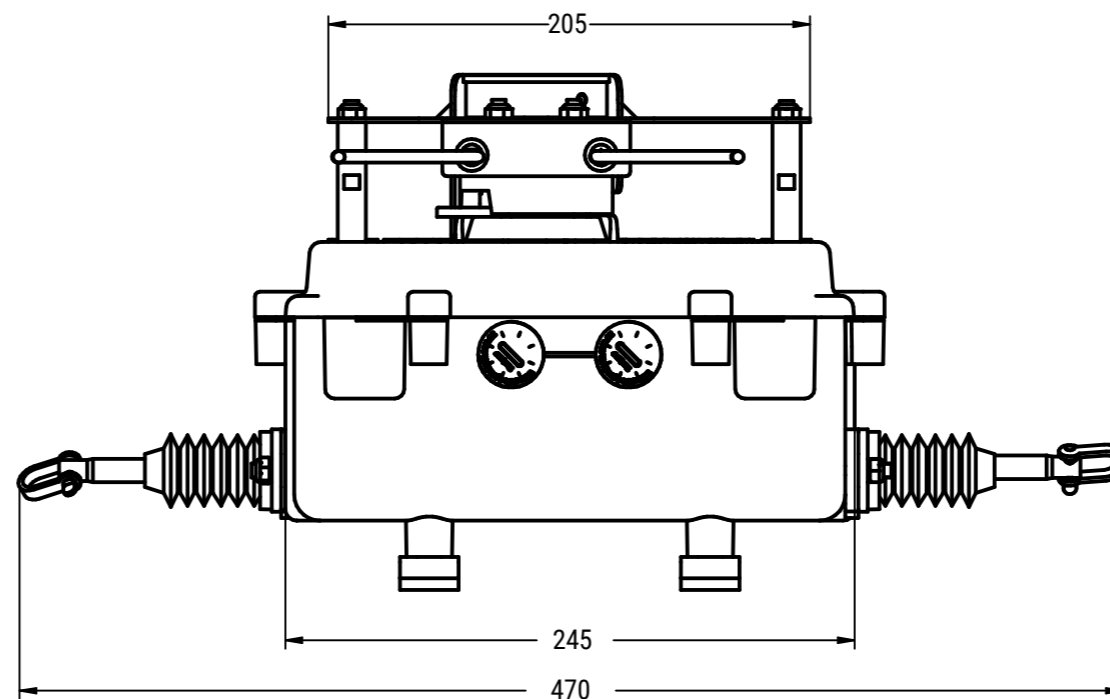
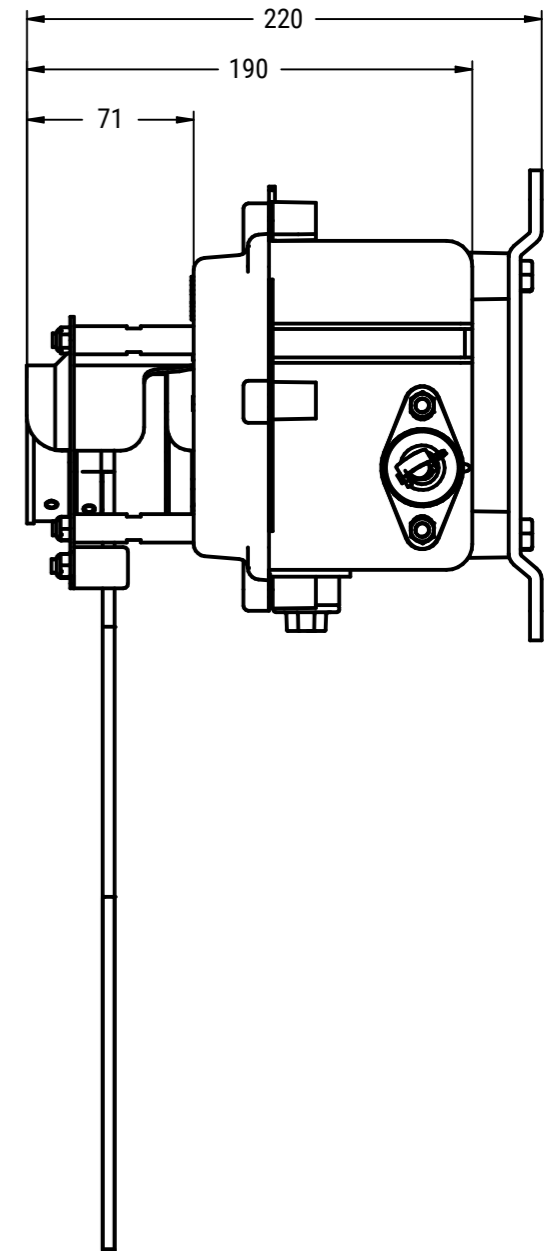
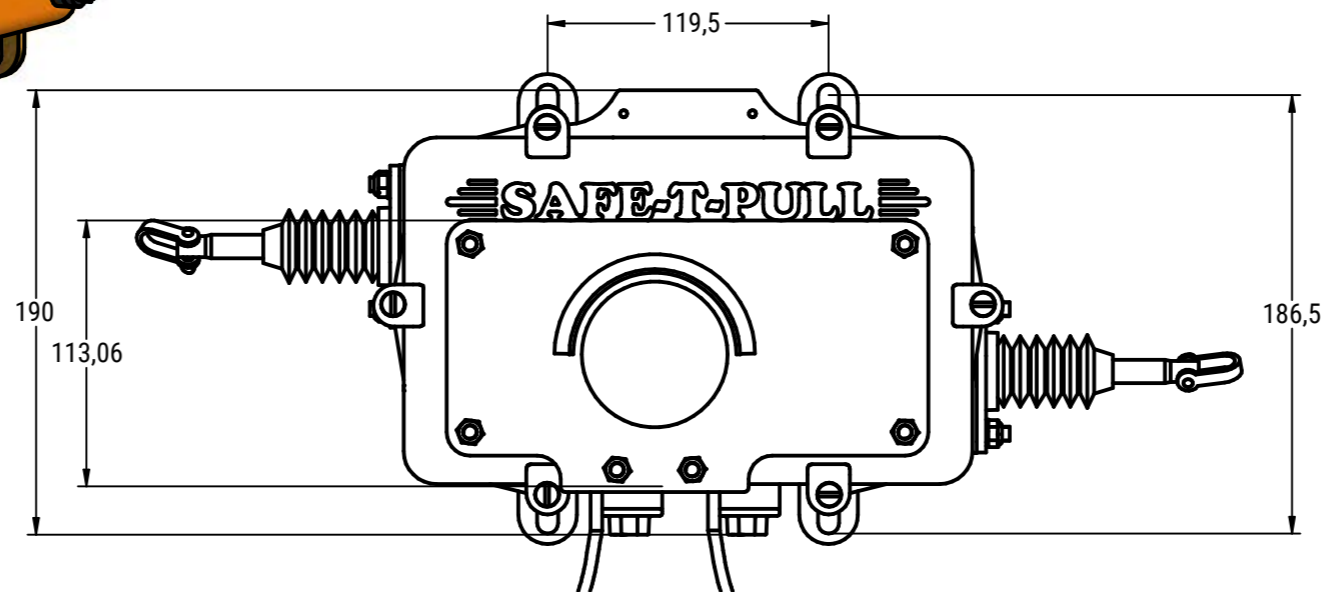

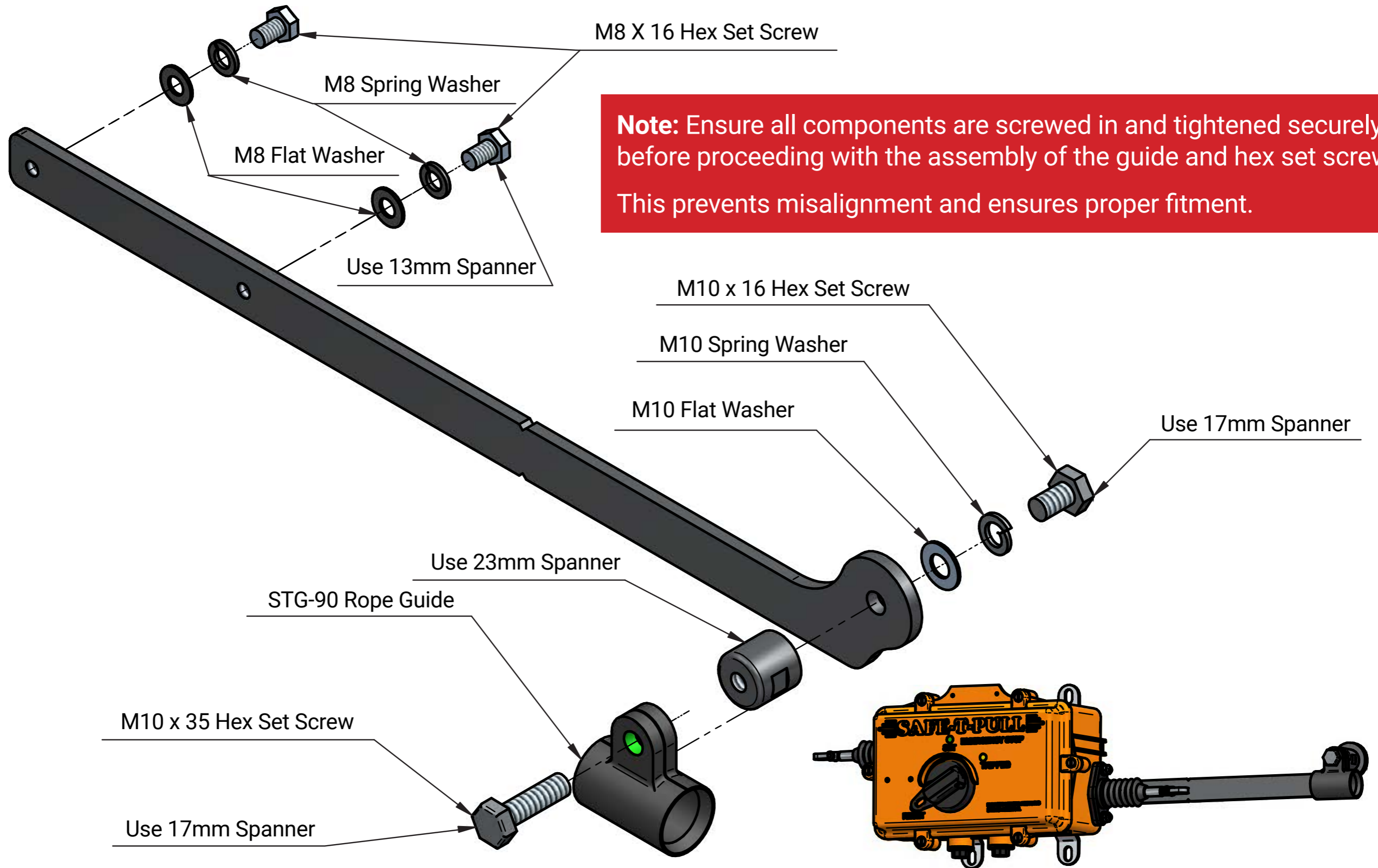

Note: After tightening, ensure that the rope guide remains loose and is not under tension.

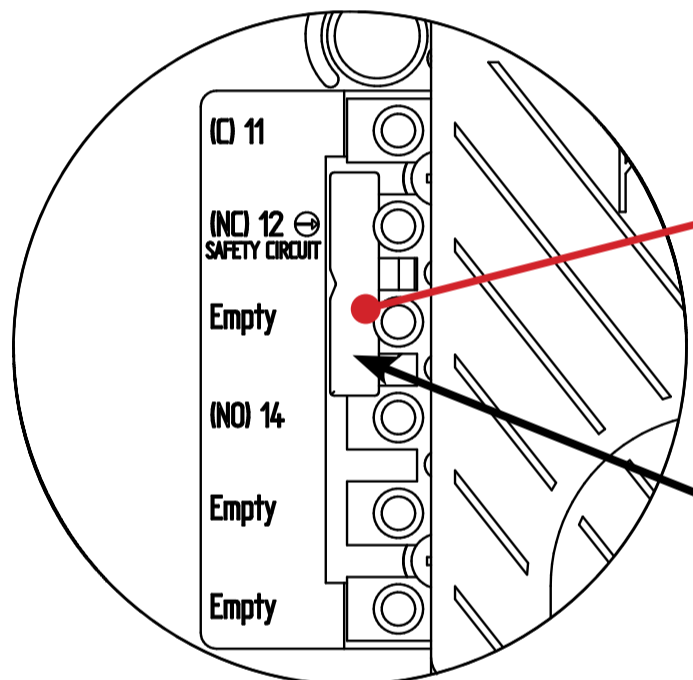
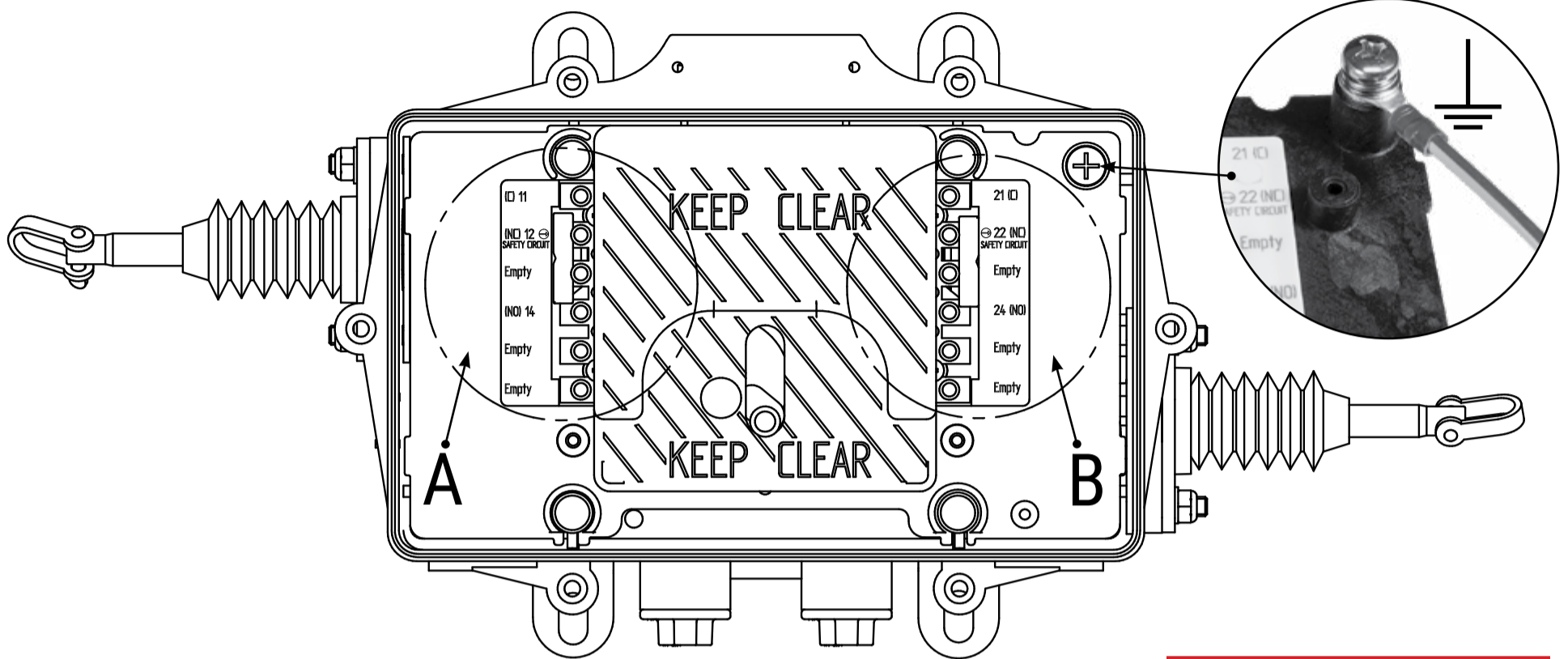

DETAIL A

SLIDE

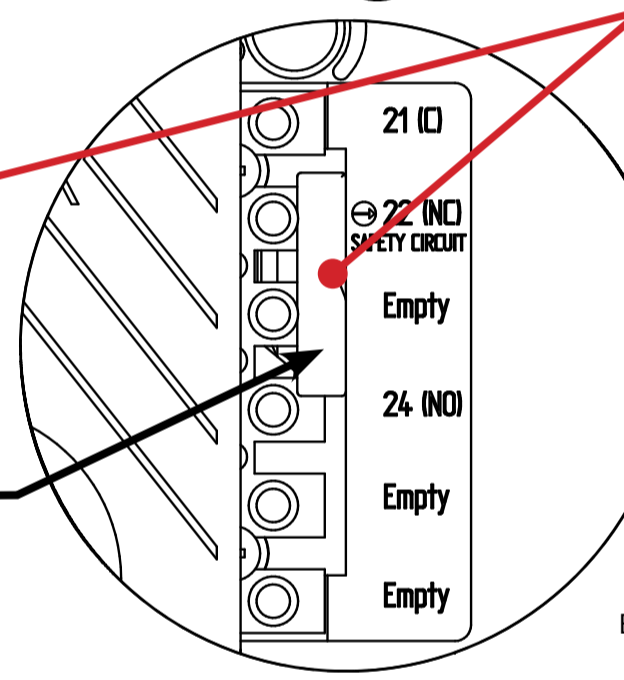

DETAIL B

TERMINAL BLOCKER
IMPORTANT NOTE:
 IEC 60947-5-1 2016
 AS 60947-5-1 2015 Clause K.7.1.4.6.1
 Form C or Form Za change over contact elements. Only one contact element (Make or Break) in each switch shall be used.
 The blocker moves to block off the unused contact.

AS SHOWN IN DETAIL A

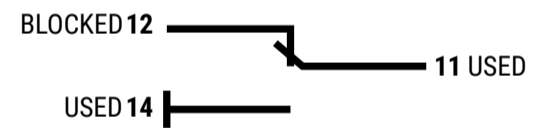

GENERAL CHARACTERISTICS

| Safety Micro Switch with Direct Opening Action Specifications | | |
|---|---------------------------------------|---|
| IEC 60947-5-1 Annex K classification | Type 1 <input type="checkbox"/> | <input checked="" type="checkbox"/> Type 2 Direct Opening |
| Change-over contact element | <input checked="" type="checkbox"/> C | <input type="checkbox"/> Za <input type="checkbox"/> Zb |
| Contact material | Ag-Ni | |
| Utilization category | AC-15 | DC-13 |
| Operational voltage | 250 V | 60 V DC |
| Operational current | 1,5 A | 0.5 Amp DC |
| Frequency | 50/60 Hz | -- |
| Number of electrical cycles | 6050 (6 min-1) | |
| Number of mechanical cycles | 6050 (6 min-1) | |
| Conventional free air thermal current | 10A | |
| Conventional enclosed thermal current | -- | |
| IP Rating | 67 | |
| Service Temperature | -30° C No Icing | +80° C |

| Specifications (short-circuit with standability) | | |
|--|---------------------------|---------------------------|
| Rated conditional short-circuit current | 3 00 A | 1 000 A |
| Short circuit protective device | Fuse 6 A gG (IEC 60269-2) | Fuse 6 A gR (IEC 60269-4) |

CIRCUIT INFORMATION

2 X FORM C SAFETY SWITCHES FITTED WITH DIRECT OPENING ACTION IP66/67

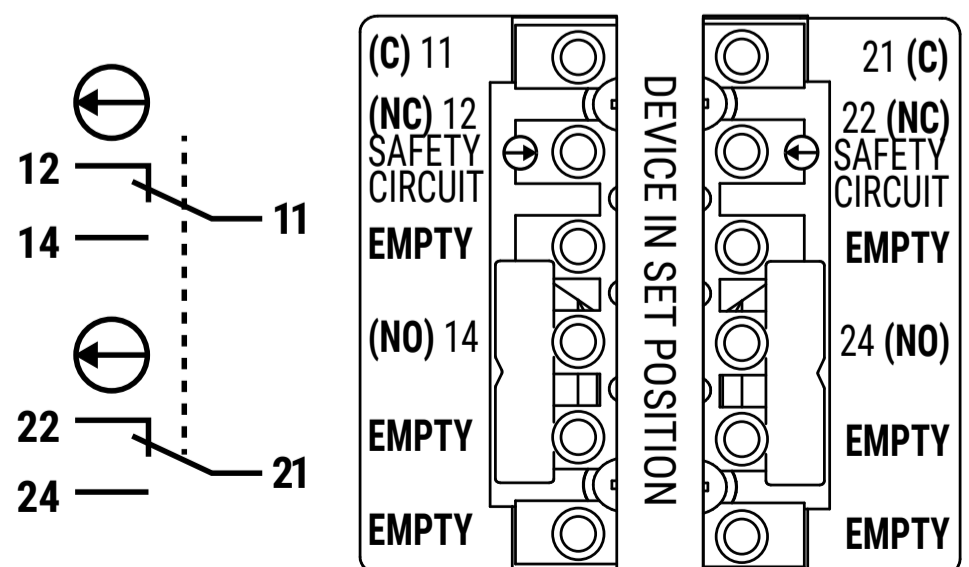

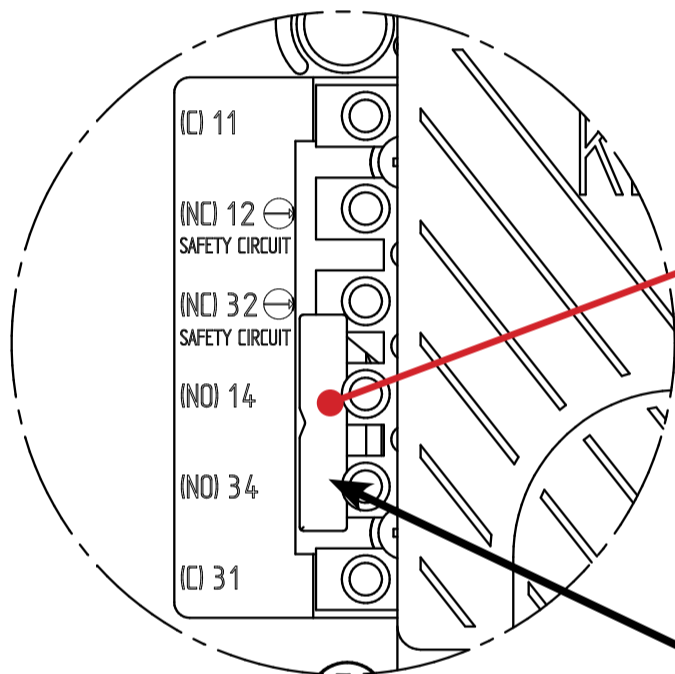
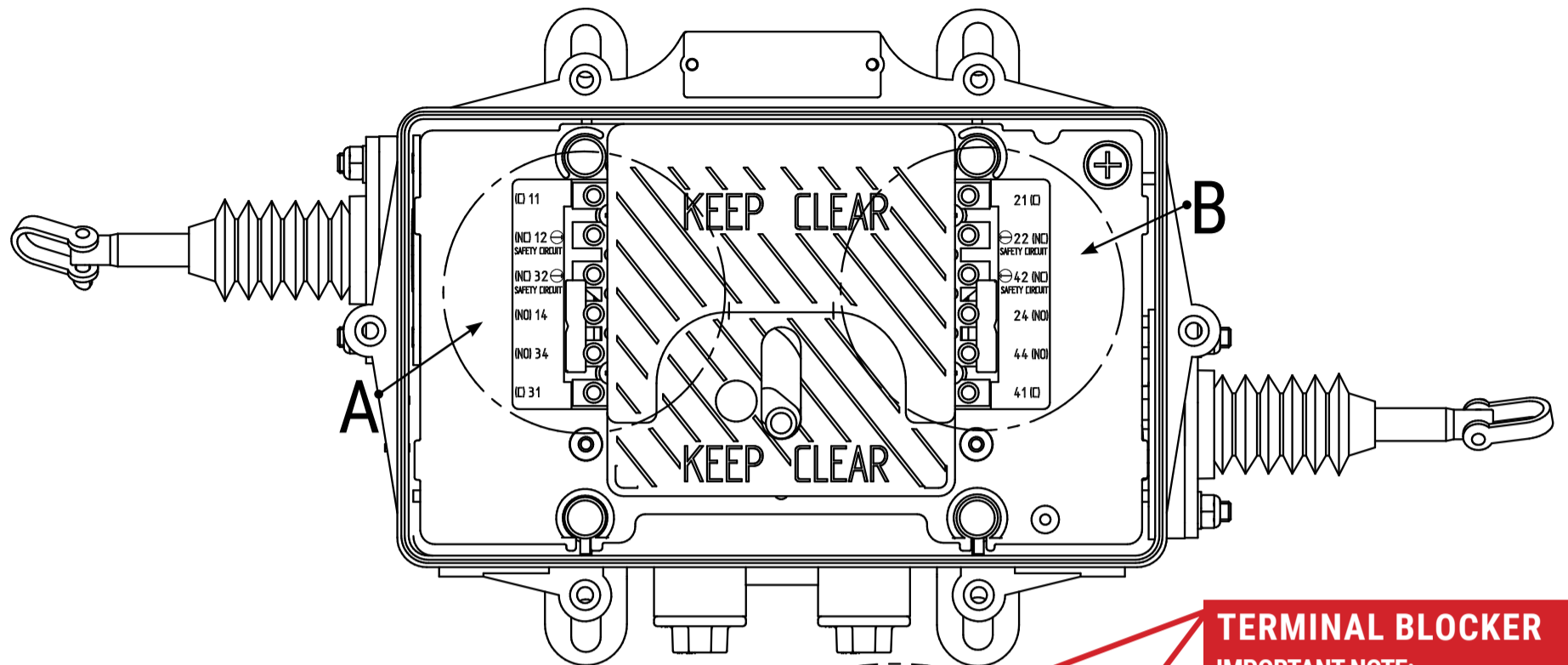

DETAIL A

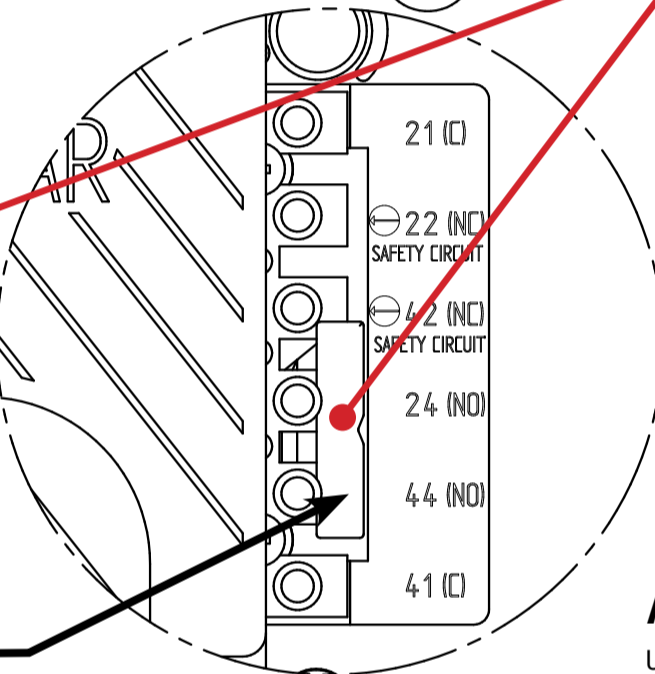

DETAIL B

TERMINAL BLOCKER

IMPORTANT NOTE:

IEC 60947-5-1 2016
AS 60947-5-1 2015 Clause K.7.1.4.6.1

Form C or Form Za change over contact elements. Only one contact element (Make or Break) in each switch shall be used.

The blocker moves to block off the unused contact.

AS SHOWN IN DETAIL A



GENERAL CHARACTERISTICS

Safety Micro Switch with Direct Opening Action Specifications

| | | |
|---------------------------------------|---------------------------------------|---|
| IEC 60947-5-1 Annex K classification | <input type="checkbox"/> Type 1 | <input checked="" type="checkbox"/> Type 2 Direct Opening |
| Change-over contact element | <input checked="" type="checkbox"/> C | <input type="checkbox"/> Za <input type="checkbox"/> Zb |
| Contact material | Ag-Ni | |
| Utilization category | AC-15 | DC-13 |
| Operational voltage | 250 V | 60 V DC |
| Operational current | 1,5 A | 0.5 Amp DC |
| Frequency | 50/60 Hz | -- |
| Number of electrical cycles | 6050 (6 min-1) | |
| Number of mechanical cycles | 6050 (6 min-1) | |
| Conventional free air thermal current | 10A | |
| Conventional enclosed thermal current | -- | |
| IP Rating | 67 | |
| Service Temperature | -30° C No Icing | +80° C |

Specifications (short-circuit with standability)

| | | |
|---|---------------------------|---------------------------|
| Rated conditional short-circuit current | 3 00 A | 1 000 A |
| Short circuit protective device | Fuse 6 A gG (IEC 60269-2) | Fuse 6 A gR (IEC 60269-4) |

CIRCUIT INFORMATION

4 X FORM C SAFETY SWITCHES FITTED WITH DIRECT OPENING ACTION IP66/67

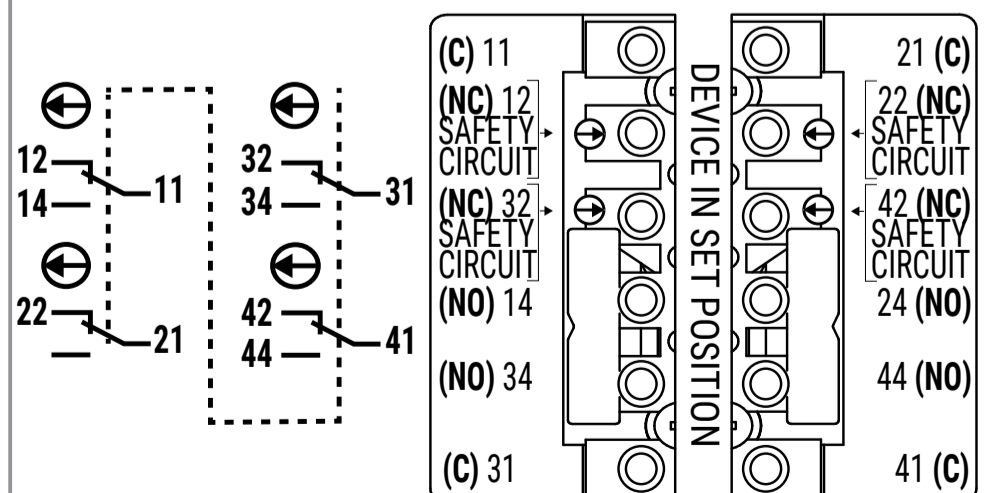

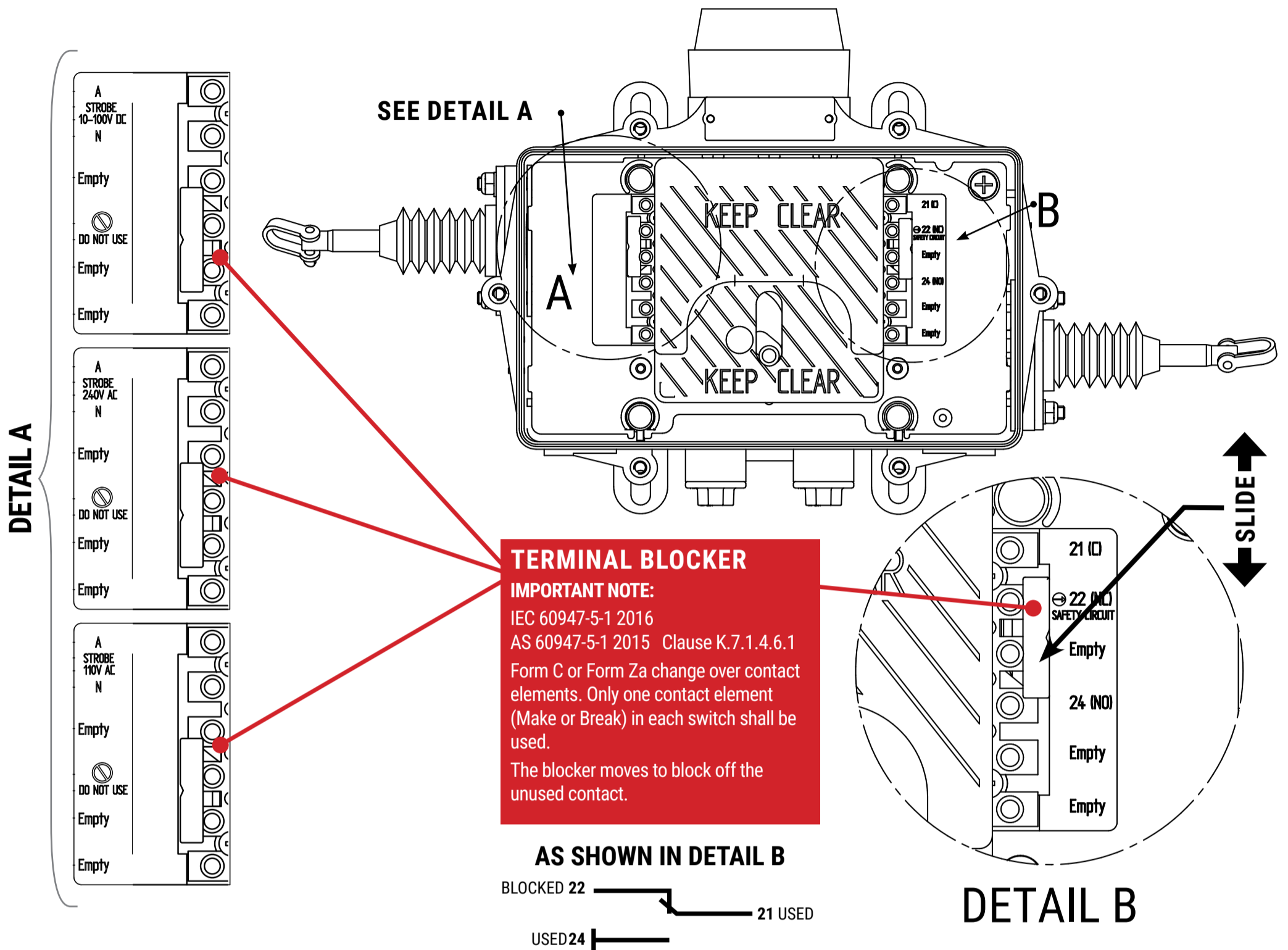

| RED STROBE | |
|------------|------------|
| -S2 | 10-100V DC |
| -S3 | 110V AC |
| -S4 | 240V AC |

| AMBER STROBE | |
|--------------|------------|
| -S6 | 10-100V DC |
| -S7 | 110V AC |
| -S8 | 240V AC |

GENERAL CHARACTERISTICS

Safety Micro Switch with Direct Opening Action Specifications

| | | |
|---------------------------------------|---------------------------------------|---|
| IEC 60947-5-1 Annex K classification | <input type="checkbox"/> Type 1 | <input checked="" type="checkbox"/> Type 2 Direct Opening |
| Change-over contact element | <input checked="" type="checkbox"/> C | <input type="checkbox"/> Za <input type="checkbox"/> Zb |
| Contact material | Ag-Ni | |
| Utilization category | AC-15 | DC-13 |
| Operational voltage | 250 V | 60 V DC |
| Operational current | 1,5 A | 0.5 Amp DC |
| Frequency | 50/60 Hz | -- |
| Number of electrical cycles | 6050 (6 min-1) | |
| Number of mechanical cycles | 6050 (6 min-1) | |
| Conventional free air thermal current | 10A | |
| Conventional enclosed thermal current | -- | |
| IP Rating | 67 | |
| Service Temperature | -30° C No Icing | +80° C |

CIRCUIT INFORMATION

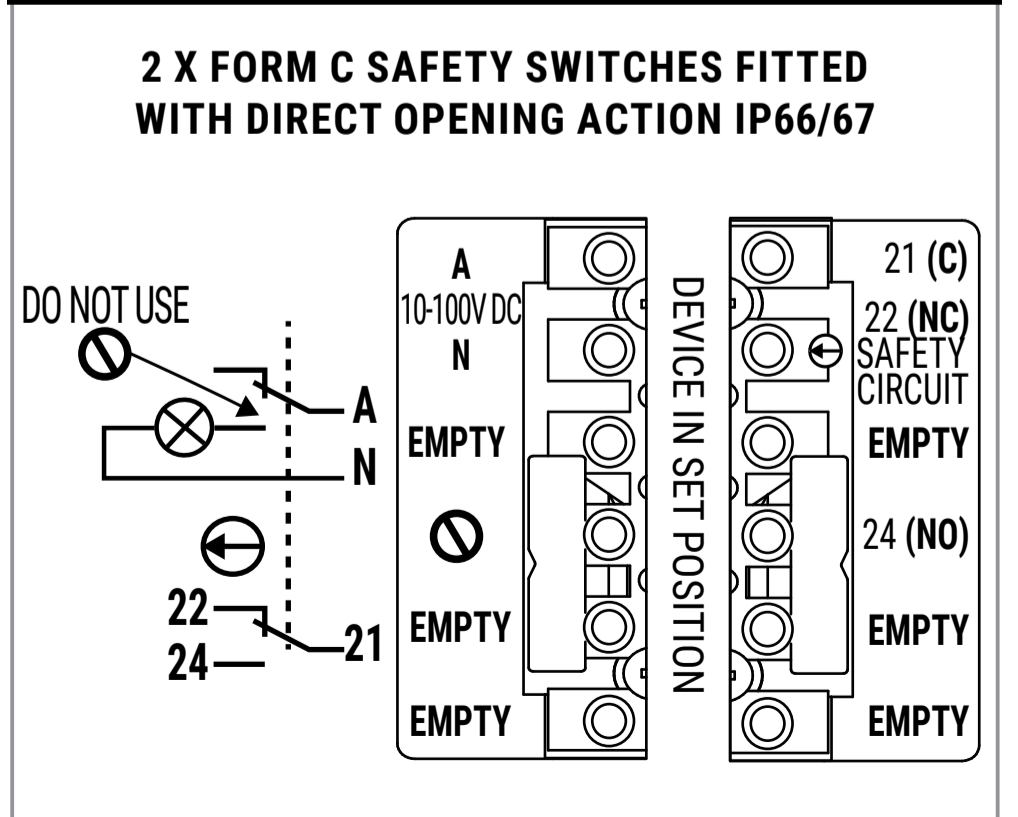

Specifications (short-circuit with standability)

| | | |
|---|---------------------------|---------------------------|
| Rated conditional short-circuit current | 3 00 A | 1 000 A |
| Short circuit protective device | Fuse 6 A gG (IEC 60269-2) | Fuse 6 A gR (IEC 60269-4) |

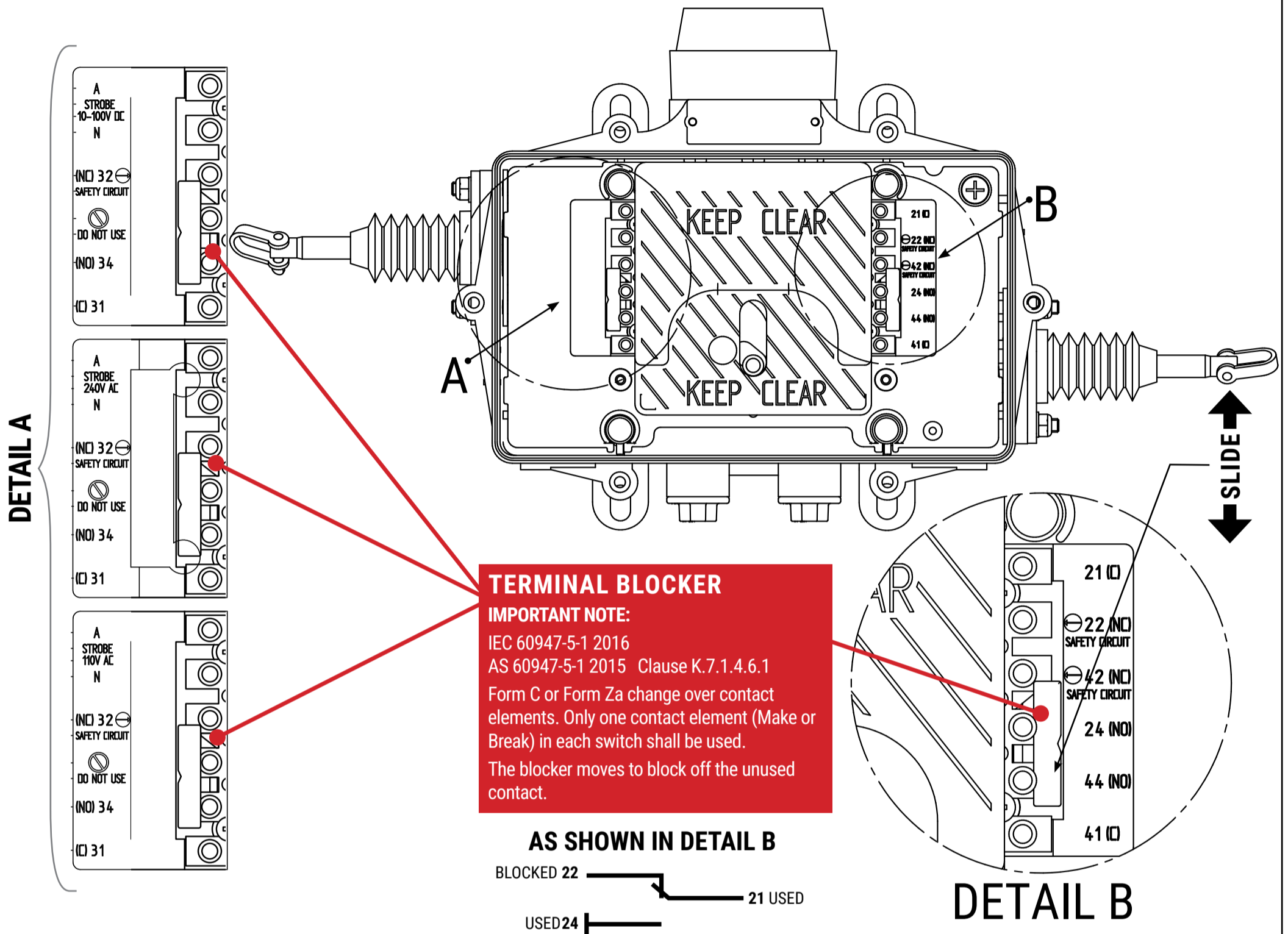

| RED STROBE | |
|------------|------------|
| -S2 | 10-100V DC |
| -S3 | 110V AC |
| -S4 | 240V AC |

| AMBER STROBE | |
|--------------|------------|
| -S6 | 10-100V DC |
| -S7 | 110V AC |
| -S8 | 240V AC |

GENERAL CHARACTERISTICS

Safety Micro Switch with Direct Opening Action Specifications

| | | |
|---------------------------------------|---------------------------------------|---|
| IEC 60947-5-1 Annex K classification | <input type="checkbox"/> Type 1 | <input checked="" type="checkbox"/> Type 2 Direct Opening |
| Change-over contact element | <input checked="" type="checkbox"/> C | <input type="checkbox"/> Za <input type="checkbox"/> Zb |
| Contact material | Ag-Ni | |
| Utilization category | AC-15 | DC-13 |
| Operational voltage | 250 V | 60 V DC |
| Operational current | 1,5 A | 0.5 Amp DC |
| Frequency | 50/60 Hz | -- |
| Number of electrical cycles | 6050 (6 min-1) | |
| Number of mechanical cycles | 6050 (6 min-1) | |
| Conventional free air thermal current | 10A | |
| Conventional enclosed thermal current | -- | |
| IP Rating | 67 | |
| Service Temperature | -30° C No Icing | +80° C |

CIRCUIT INFORMATION

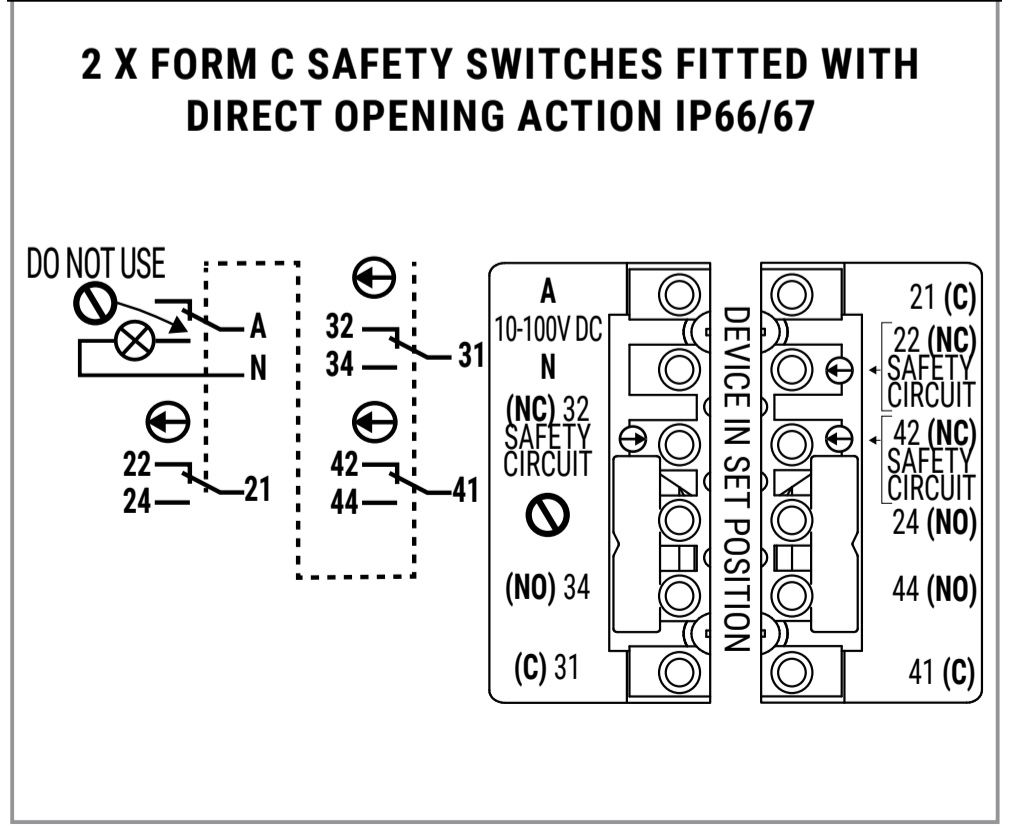

Specifications (short-circuit with standability)

| | | |
|---|---------------------------|---------------------------|
| Rated conditional short-circuit current | 3 00 A | 1 000 A |
| Short circuit protective device | Fuse 6 A gG (IEC 60269-2) | Fuse 6 A gR (IEC 60269-4) |

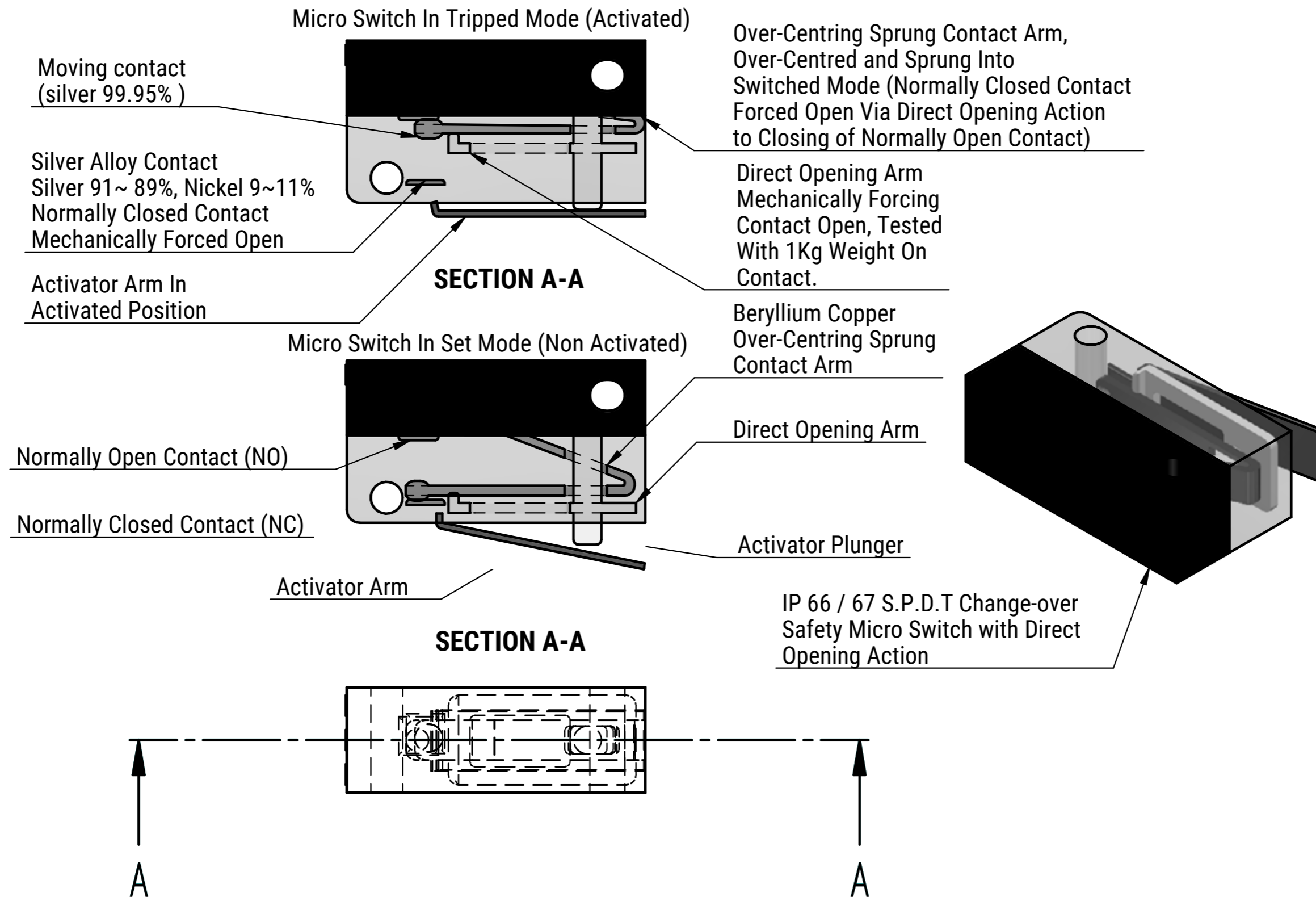

STP-P-* STP-A-* STP-SSB-*

STANDARD

The Safe-T-Pull complies with the relevant parts of these Standards

| | |
|---------------------------|---|
| IEC 60947-5-1 Ed 3.1 | Control circuit devices & switching elements |
| AS/NZS IEC 60947-5-1:2015 | Control circuit devices & switching elements |
| IEC 60947-5-5 Ed 1.1 | Control circuit devices & switching elements-Electrical emergency stop devices with mechanical latching function. |
| AS/NZS IEC 60947.5.5:2015 | Control circuit devices & switching elements-Electrical emergency stop devices with mechanical latching function. |
| AS/NZS 4024.1-2014 | Safety of Machinery. |
| AS/NZS 4024.3610:2015 | Safety of Machinery, conveyors, general requirements. |
| AS/NZS 4024.3611:2015 | Safety of Machinery, conveyors, belt conveyors for bulk materials handling. |

Ce Conformity to:

| | |
|------------|-----------------------|
| 2006/42/EC | Machinery Directive |
| 2014/35/EU | Low Voltage Directive |

WORKSHOP TESTED

All devices are either hand or automation tested by trained technicians before leaving Safe-T-Products and have a date and name label of manufacture inside them. The devices are then packed insuring full working order to our stringent test parameters.

A certification certificate is available on request for full compliance to the relevant standards.

MODIFICATIONS OF DEVICE

Any modifications are ONLY to be made by Safe-T-Products or one of their registered repairers. Any unauthorized modifications may not comply with the relevant standards and may diminish the integrity and workings of the device and the warranty will become void.

Safe-T-Products and their registered repairers or distributors will not be responsible for any damage caused to the altered device or any item in, on, related or near the device, nor any injury incurred, nor actions resulting from the unauthorized alterations.

RETURNS POLICY/RE-STOCKING

Please return any defective device to place of purchase for assessment. If they are deemed to be warranty repairs or not. Return warranty devices as per warranty clause. Restocking returns will only be accepted if received by Safe-T-Products in their original condition and within thirty (30) days of delivery date stated on delivery documentation. A restocking fee applies (contact place of purchase for costs).

WARRANTY

Safe-T-Products of Perth Western Australia contact info@safe-t-products.com.au warranty period is Twenty Four (24) months from date of purchase or longer if indicated by Safe-T-Products. For warranty to be valid the goods must be received by Safe-T-Products before the end of the Twenty Four (24) month period. Safe-T-Products warrants that if any product is defective, it will, at its option, replace or repair the product. This warranty shall not apply to any defect which arises from improper use, failure to follow the products instruction, or any repair or modification made without the consent of Safe-T-Products.

The customer must contact the Distributor of the product or Safe-T-Products of Perth Western Australia via Email info@safe-t-products.com.au before returning the faulty product. If returned they must be suitably packaged and, where relevant, returned in accordance with any particular instructions which Safe-T-Products or one of its distributors may have notified the customer at the time of contact for warranty. Returned products must be accompanied by an advice note stating the nature of any defect being claimed. Any products or parts which are replaced by Safe-T-Products or one of its distributors shall become the property of Safe-T-Products. Title to replacement products shall pass to the customer on delivery, and the period of the warranty shall be calculated from the date of the defective product.

All warranty returns to Safe-T-Products will be sent by the customer's freight at their cost. All benefits under this warranty are in addition to other rights and remedies of the consumer under a law in relation to the goods or services to which the warranty relates. Our goods come with guarantees that cannot be excluded under the Australian Consumer Law. You are entitled to a replacement or refund for a major failure and for compensation for any other reasonably foreseeable loss or damage. You are also entitled to have the goods repaired or replaced if the goods fail to be of acceptable quality and the failure does not amount to a major failure.

STP-P-* STP-A-* STP-SSB-*

PRODUCT LIFE EXPECTANCY

Safe-T-Products estimate the product life expectancy to 10-15 years. Products should be changed after a maximum of 10 year life.

NOTE: Color fading is not necessarily product failure but a natural progression of any materials through it's life span. This is also dependent on the environment the product is installed in. A shorter or longer product life maybe experienced due to environmental situations. Safe-T-Products can't give a written life expectancy on any of it's products due to the different situations the products are used.

TECHNICAL SUPPORT

Technical advice will be given at any time by Safe-T-Products or Distributor on any of the Safe-T-Product range. Contact Safe-T-Products or your local Distributor for this service.

OBSOLETE PRODUCTS

Notification will be given to Distributors only for the products becoming obsolete and a time frame of when this will occur. Please contact Distributors for this information.

The obsolete product range will have spare parts for 12 months after becoming obsolete or until they run out, complete products may be available for a short time after it has become obsolete.

LOCATION OF EMERGENCY STOPS

Emergency stops shall be located at each operator control station and other locations where emergency stop is required. Conveyors not greater than 2.5m in length and less than 2.7m above the floor, walkway or platform. A single stop control at a location which is easily accessible by the operator is all that is needed.

Conveyors greater than 2.5m in length and less than 2.7m above the floor, walkway or platform. They must have an emergency stop at the head, tail, drive and intervals not exceeding 30m along the length of the conveyor. Overland and long conveyors must have emergency stops every 30m so lanyards are advised to be used for best coverage for safety critical function.

Conveyors greater than 2.7m above the floor, walkway or platform. Locate emergency stops at positions where accessible and at intervals not exceeding 100m along the conveyor. Lanyards or Emergency Stop buttons may be used.

Emergency stop at positions adjacent to the conveyor where it can be started. Emergency stop at every permanent working station.

6 MONTHLY MAINTENANCE PROCEDURE

All devices require minimal maintenance but as in AS 4024.3610-2015 maintenance procedure shall be carried out.

Check that the devices are installed as per installation instructions.

Visual inspection of enclosure to ensure IP66/67 rating and correctly operating device. I.e. Damaged enclosure, bent pull rod, damaged dust boot etc.

Inspect all attachments are tight, free from obstructions and not worn and replace if necessary.

Inspect pull cord supports for wear, deterioration and build up of material, replace if necessary.

Inspect pull cord for wear or deterioration and replace if necessary.

Check that the pull rods are tensioned to the set position as per installation instructions, using either tape measure/ruler or **STP-SUG** gauge supplied with the device. (See page 1 for information)

NOTE: Pigtails and Eyebolts make very high static friction points and cause excessive wear and system disruption. Safe-T-Products recommends the Safe-T-Guide for critical safety function.

PRODUCT SURFACE TREATMENT

STAINLESS STEEL ELECTRO POLISHING

Safe-T-Products' electro-polishing of its 316 stainless steel enclosures ensures product longevity in harsh conditions. By effectively removing all contaminants and iron from the surface of the stainless steel and drawing the chromium to the surface, this process creates a clean, non-rusting, and sterile surface. This level of precision and attention to detail in the treatment process ensures that stainless steel components remain corrosion-resistant and maintain their functionality and appearance over time.

POWDER COATED ALUMINIUM

The powder coat used on the aluminum products is a halogen-free, low-smoke, orange or yellow polyester coating. This coating improves the longevity of the aluminum surface and resists corrosion in harsh environments.

STP-P-* STP-A-* STP-SSB-*

SAFE-T-SPRING

The STP-E60 is the replacement of the STP-H60 compensation spring.

The STP-E60 reduces spring friction and material build up; As a result, the emergency stop system is more reliable with less maintenance needed.

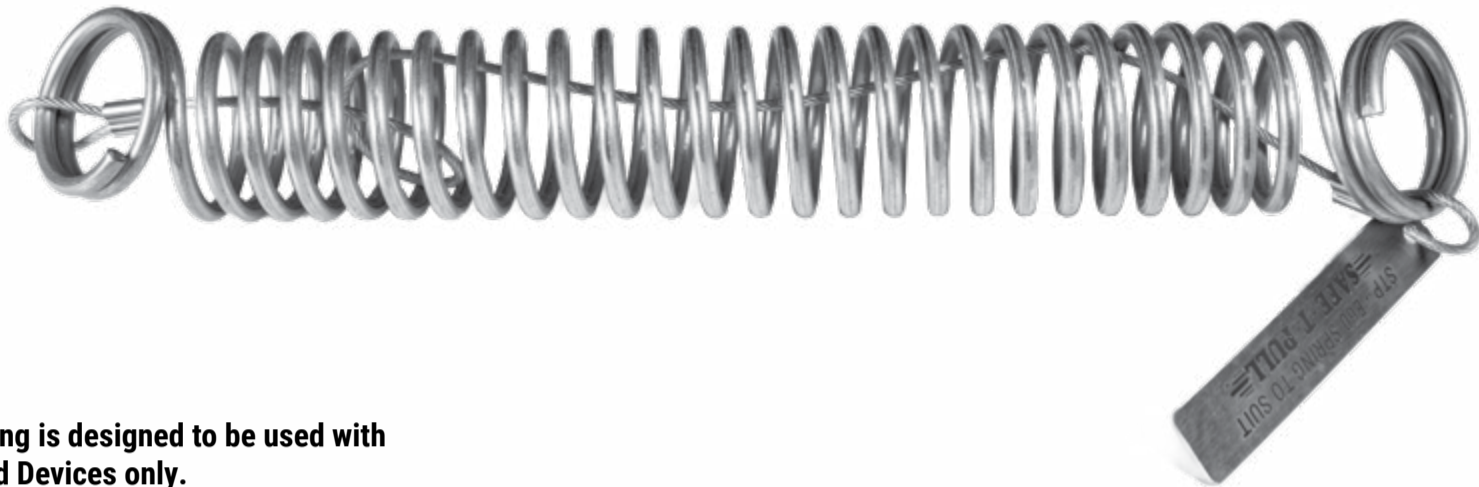

Compensation Spring is designed to be used with Safe-T-Pull Lanyard Devices only.

STP-E60 COMPENSATION SPRING REFERENCE

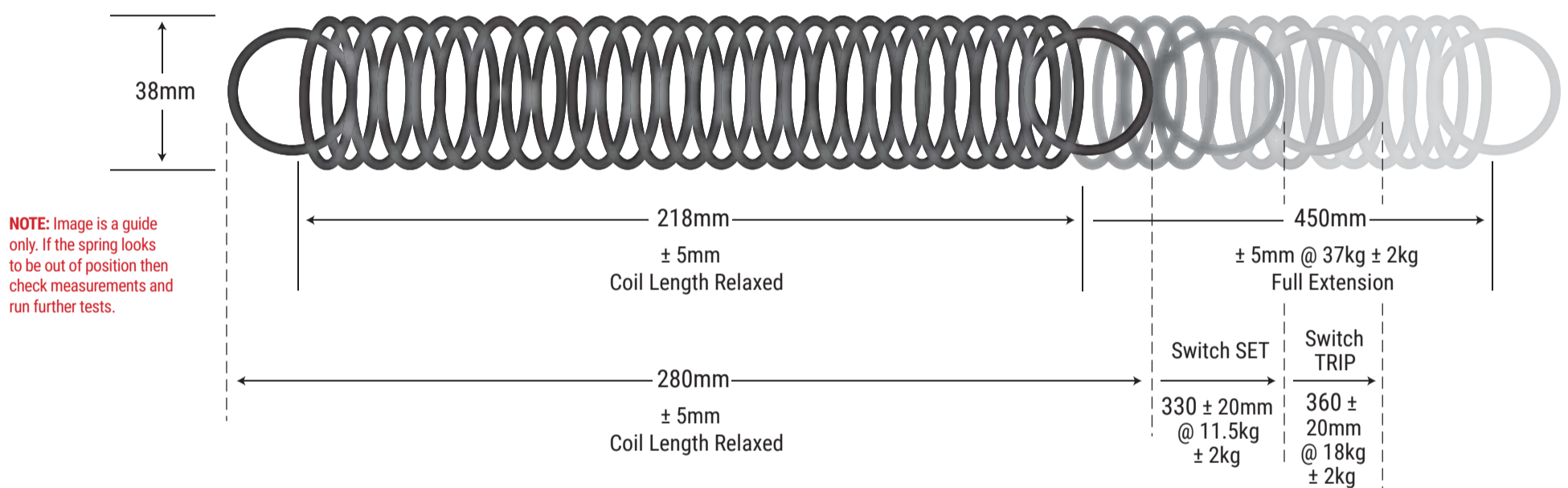

FULL SAFETY MAINTENANCE PROCEDURE AT 12 MONTH RECOMMENDED INTERVALS, OR AS PER APPLIED RISK ASSESSMENT

TEST 1

Test that the Safe-T-Pull Cord operates correctly.

This test is best done at the spring end of the pull cord system. This only needs to be done in each direction once. After each trip a device will need to be reset before the next test is to be conducted.

The system should pull and trip easily in each direction. No recorded pull measurements are needed for this test. This is just a pull cord movement test before test 2 is performed.

If the pulling of the cord is difficult or feels hard (should be less than, 10Kgf) then check the installation for worn pull cord, sharp bends, bent supports or items trapping the cord. If the problem is still present, contact the supplier of the product for advice.

NOTE: Keeping the pull cord straight or making sure to use long curved bends or **STG-ERD-E** roller guides to bend around corners should keep the pull parameters in check.

TEST 1

AXIS PULL CORD TEST

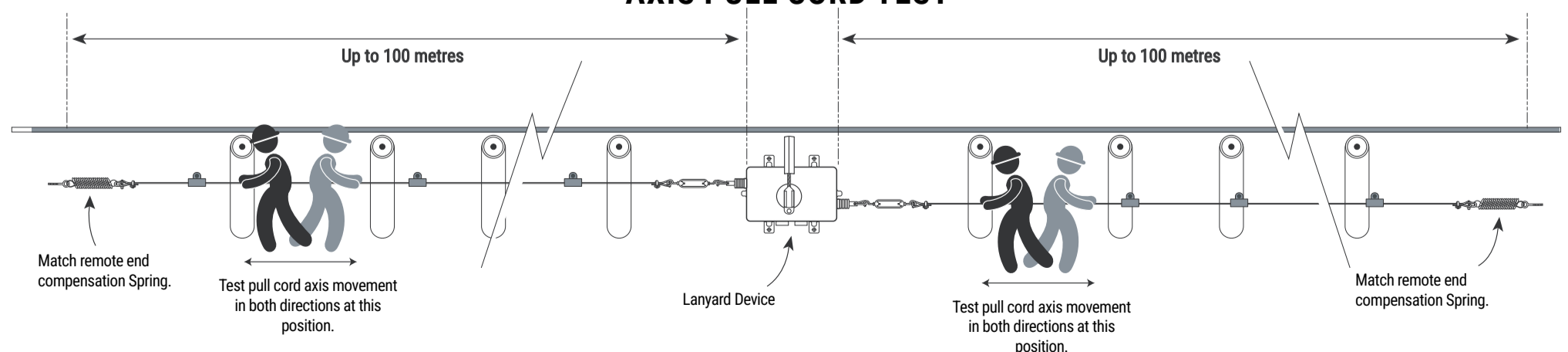

TEST 2

Reset and attach calibrated or some other calibrated weight measurement device to the pull cord (See Figure 2), 90 degrees to the pull cord axis. A length measurement needs to be taken as well in this test. The test needs to be conducted 90 degrees to the pull cord's axis.

Pull the cord 90 degrees to the axis quickly using the calibrated or some other calibrated weight measurement device, measure the amount of force it takes to trip the device. There will be some over pull in this test so factor this into the measurement. Once the device trips check to see how far the pull cord needs to be pulled to activate a trip. An easy way to take this measurement when pulling the cord with the scales attached is start with your arm out stretched and pull quickly towards you stopping when your arm is bent 90 degrees next to your side, this measurement is about 400-450mm. **NOTE:** the pulling speed of the test will have an effect on the test results. As the cord is moving the whole length, faster the pull the lower the test result due to the reduction of the static friction between the cord and guides. In an emergency situation, the device will not be pulled slowly so the test should replicate this. AS 4024.3610 state the force used to activate a trip must not exceed 70N (7Kg) and the amount of pull should not exceed 300mm. **NOTE:** Safe-T-Products risk assessment allows a pull distance can be up to 450mm and a maximum of 200 N as found in AS3947.5.5 Electrical emergency stop device with mechanical latching function mechanical requirements test, AS4024.1604 allows these recommendations. Attention must be paid to the surrounding environment and if this distance may be achieved safely. The Ergonomics HB-59 standard gives an average human arm reach distance of 500mm so 450mm pull distance would be acceptable. If the problem is still present contact the supplier of the product for advice.

If Eyebolts or Pigtails are being used, then this could be a factor as they increase the pull cord friction and can give high readings. Obstructions or sharp radius bends increase friction and give high readings, the use of the roller guide (STG-200-RG-SS) is recommended. Incorrect compensation spring or the device is seized or not working correctly could be the under laying problem.

The pull parameters are also governed by the positions of the pull cord guides and the position of the set point of the pull rod. If the pull cord guides are further apart than 3m then the Nm of force to pull the cord 90 degrees will decrease but the overall pull out length will increase and this is reversed if the guides are closer than 3m. Adjust the pull rod set point position out by 5-10mm (105-110mm) for shorter pull out tripping distance. This may increase nuisance tripping if not using STL-10-V pull cord.

TEST 2

90 DEGREE PULL CORD TEST

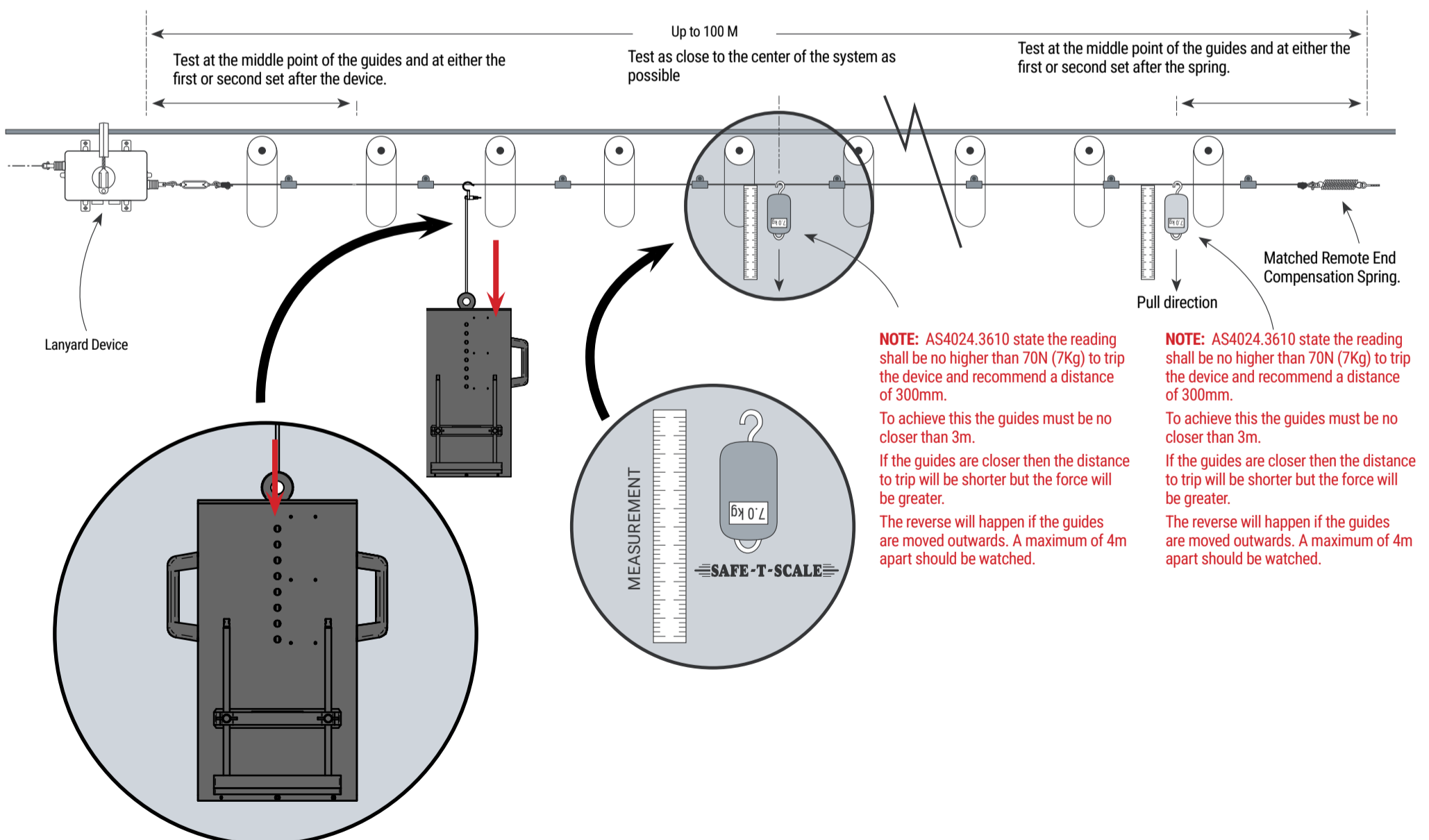

NOTE: After each activation tests are completed, visual check that the set position of the pull rods are as per installation instructions, if not readjust turnbuckle so the pull rods are at the set position before next test.

SYSTEM TESTING NOTE USING SAFE-T-TEST: TEST 1 "Axis pull cord Test" and Test 2 "90 Degree pull cord Test" are most efficiently run at the same time with two personnel walking the conveyor. A 200-metre pull cord system should take 15-20 minutes to test.

NOTE: After each activation tests are completed, visual check that the set position of the pull rods are as per installation instructions, if not readjust turnbuckle so the pull rods are at the set position before next test.

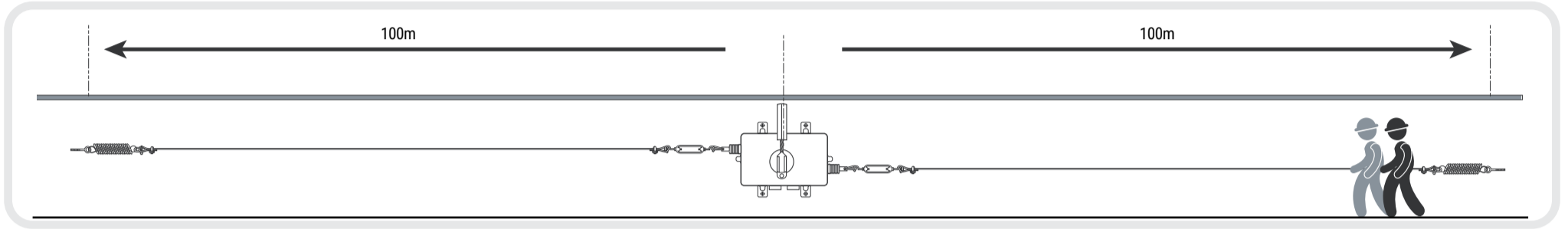

1. One person walks to the lanyard device and the other person stands at the spring and initiates the **Test 1**.

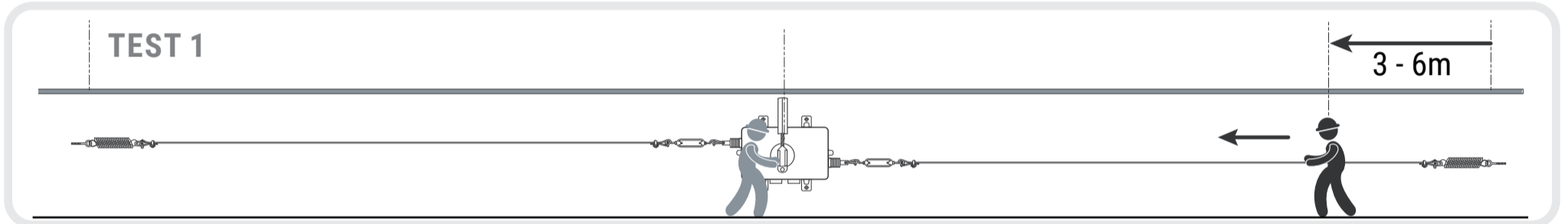

2. Once the device trips it is reset then another Test 1 is initiated in the same place but in the opposite direction.

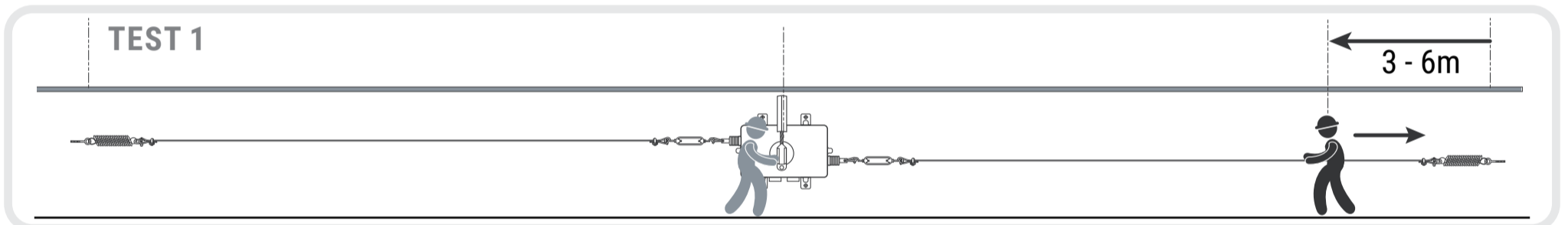

3. Then Test 2 is initiated at the spring end,

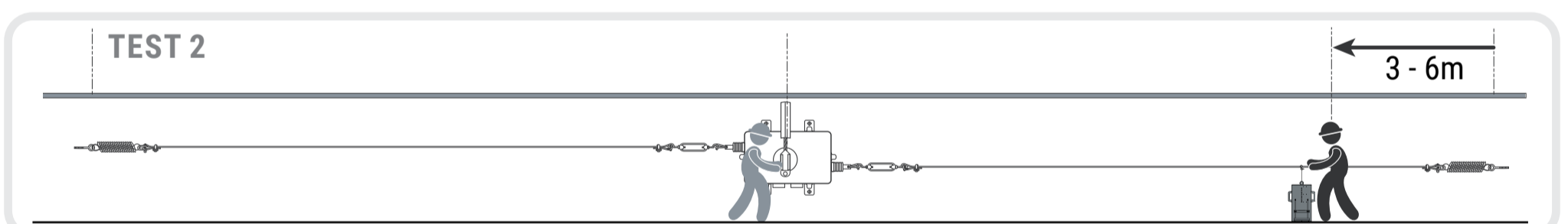

4. At the pull cord system centre between the spring and device,

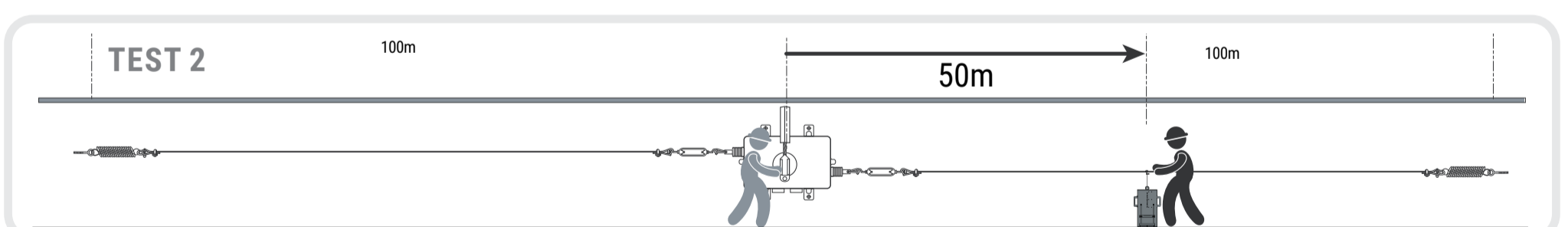

5. And the device end.

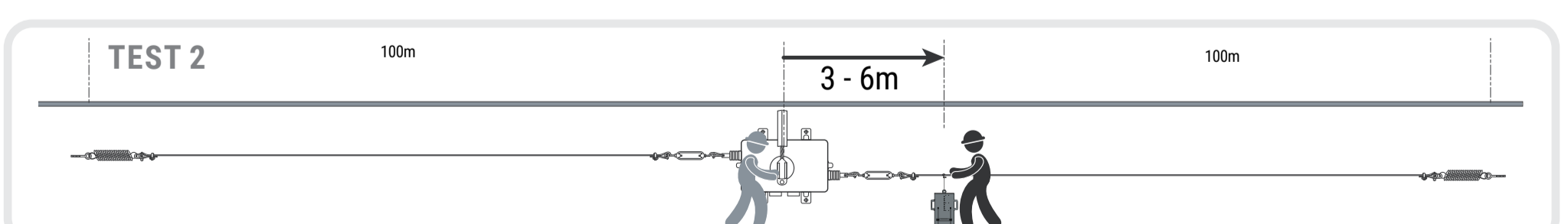

The Safe-T-Test as per the instructions and after each test the information is noted. Repeat the 5 step test on other side of device.

SYSTEM TESTING NOTE USING SAFE-T-SCALE: Test 1 "Axis pull cord Test" and Test 2 "90 Degree pull cord Test" are most efficiently run at the same time with two personnel walking the conveyor. A 200 metre pull cord system should take 15-20 minutes to test.

NOTE: After each activation tests are completed, visual check that the set position of the pull rods are as per installation instructions, if not readjust turnbuckle so the pull rods are at the set position before next test.

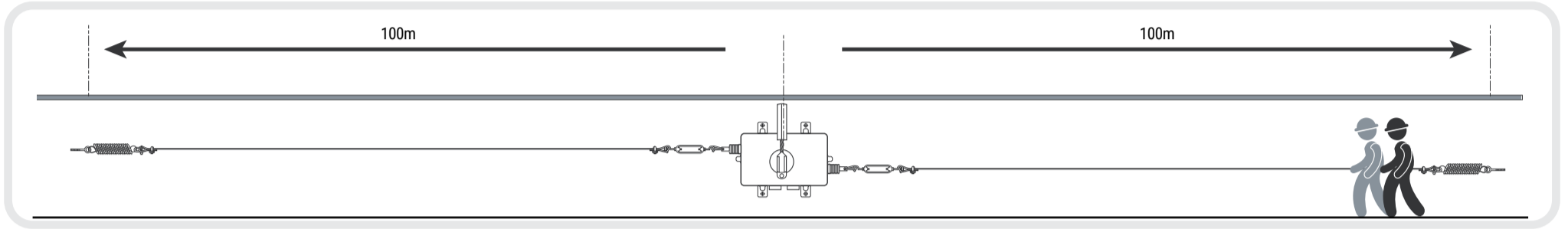

1. One person walks to the lanyard device and the other person stands at the spring and initiates the **Test 1**.

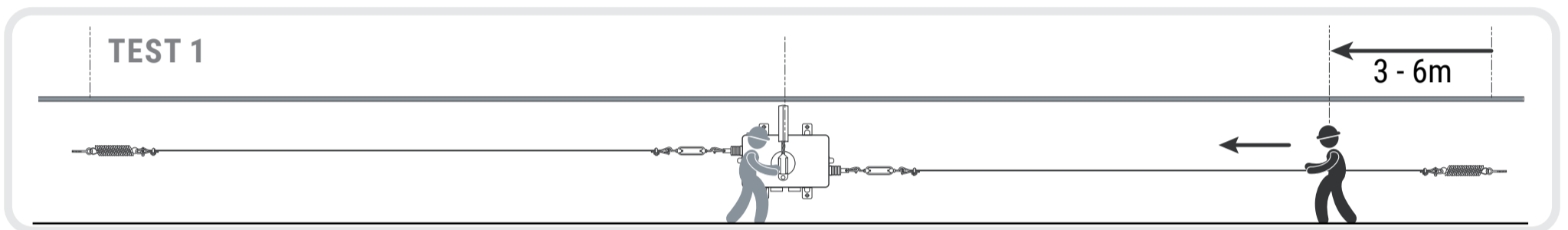

2. Once the device trips it is reset then another **Test 1** is initiated in the same place but in the opposite direction.

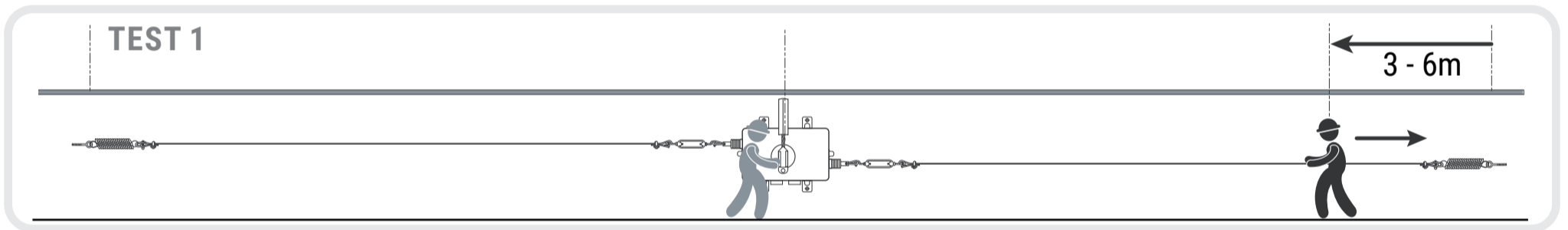

3. Then **Test 2** is initiated at the spring end,

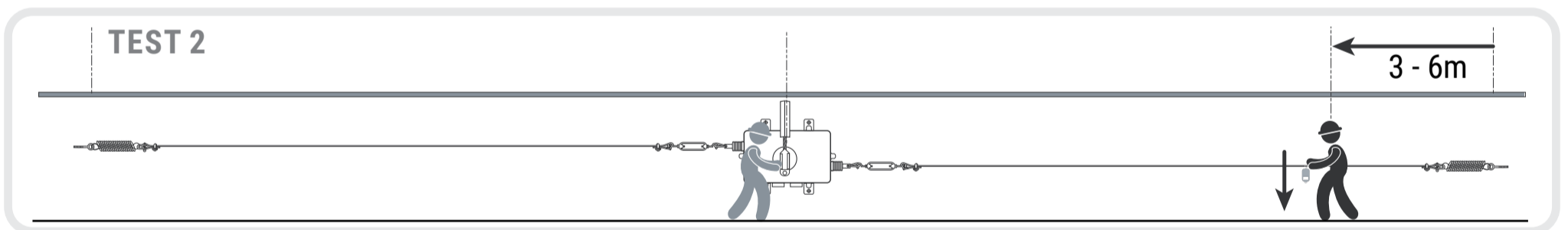

4. At the pull cord system centre between the spring and device,

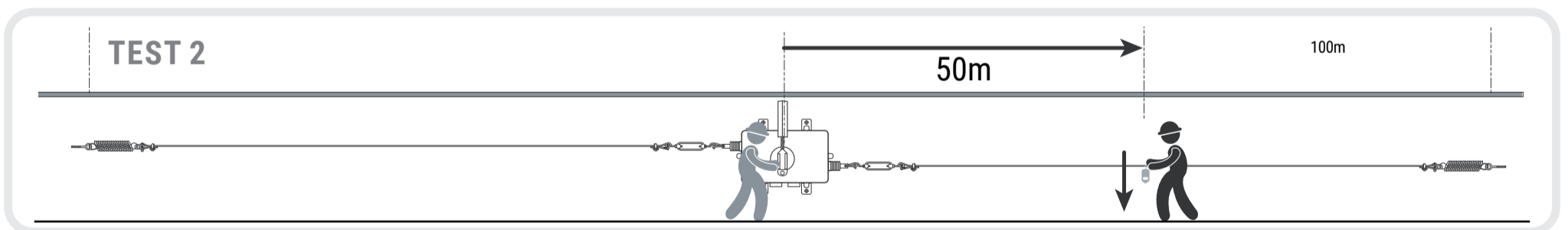

5. And the device end.

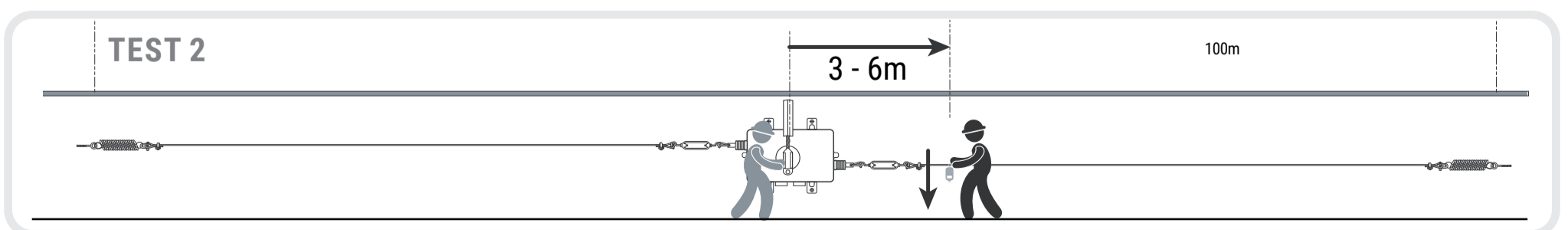

These test measurements are called out by the tester to the person at the device. The person at the device will reset the device and then document the measurements while the other person moves to the next test once one side is tested then this is repeated on the other side starting with test one and so forth.

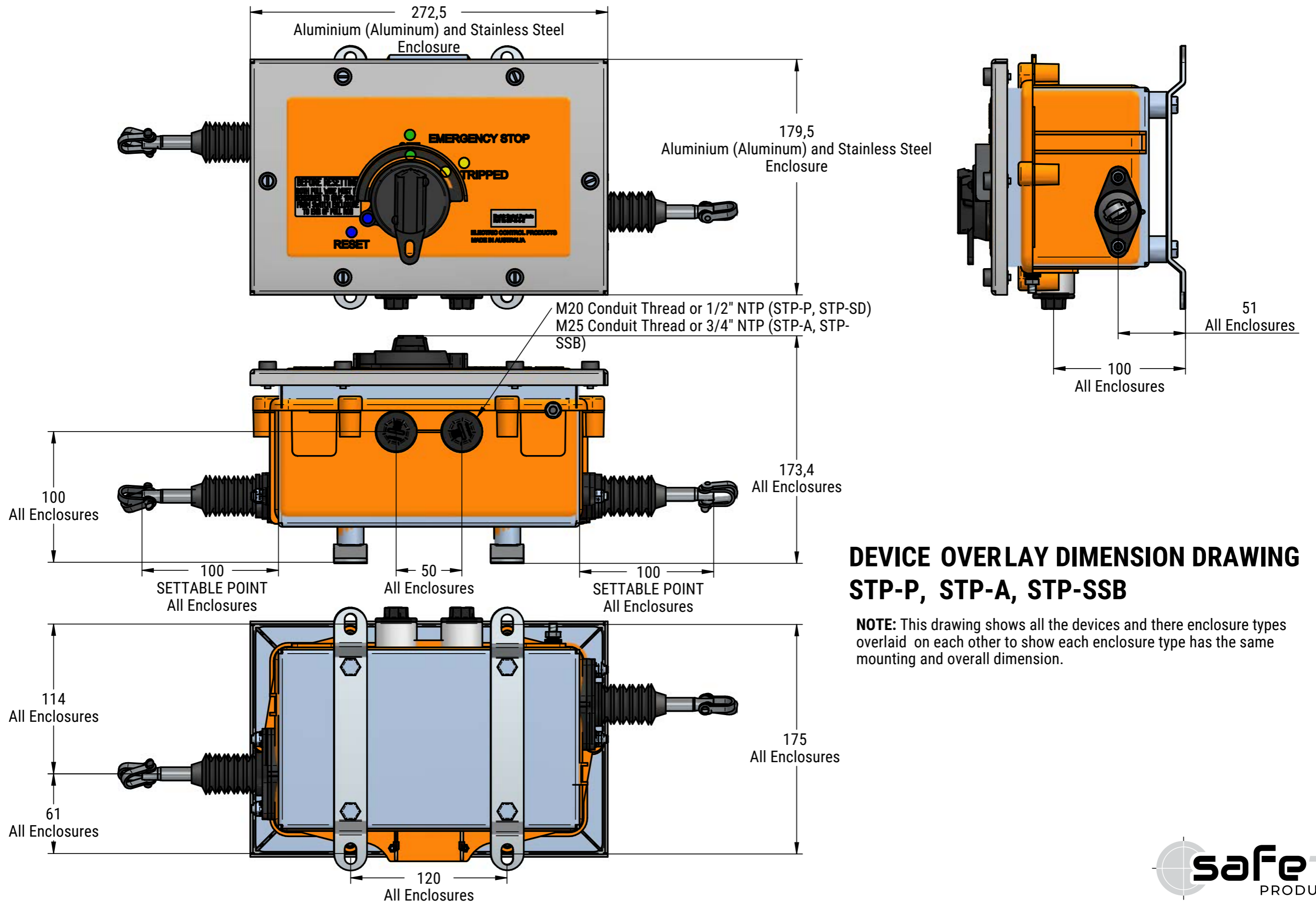

DEVICE OVERLAY DIMENSION DRAWING STP-P, STP-A, STP-SSB

NOTE: This drawing shows all the devices and there enclosure types overlaid on each other to show each enclosure type has the same mounting and overall dimension.

NOTE: The lid has a lid locking mechanism that stops the lid from being easily removed when in remote isolation.

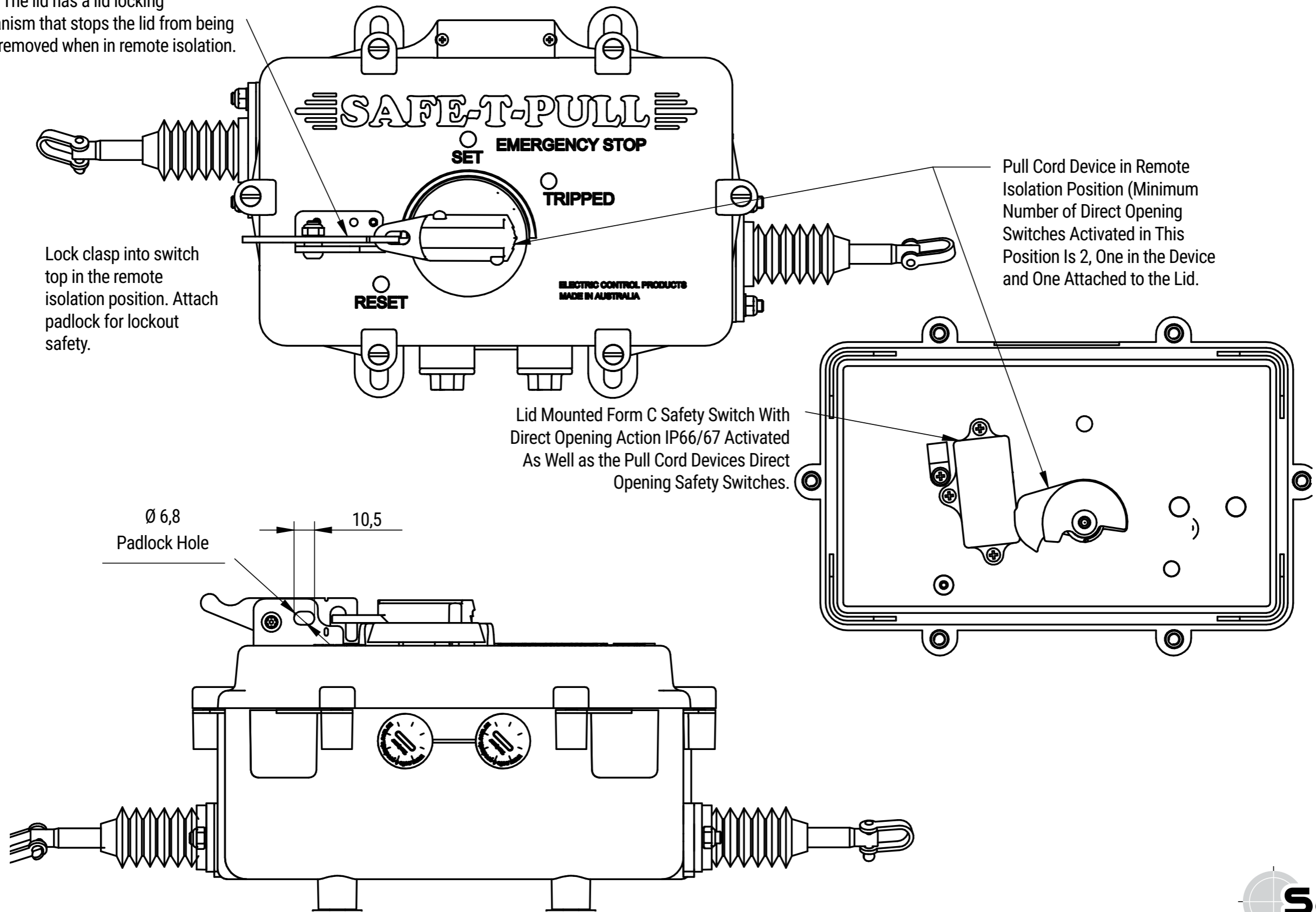

Lock clasp into switch top in the remote isolation position. Attach padlock for lockout safety.

Pull Cord Device in Remote Isolation Position (Minimum Number of Direct Opening Switches Activated in This Position Is 2, One in the Device and One Attached to the Lid).

Lid Mounted Form C Safety Switch With Direct Opening Action IP66/67 Activated As Well as the Pull Cord Devices Direct Opening Safety Switches.

$\varnothing 6,8$
Padlock Hole

10,5

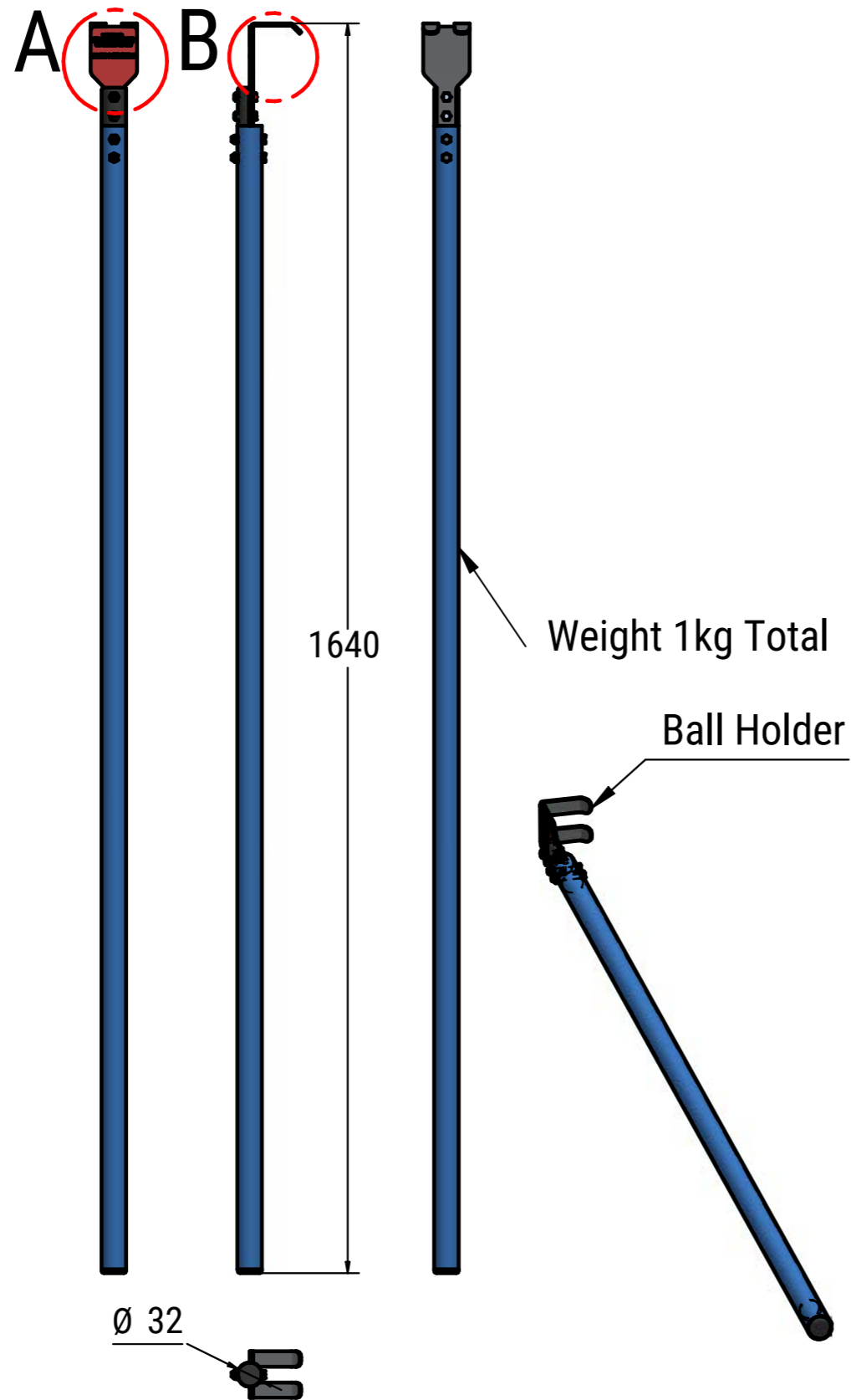

Weight 1kg Total



DETAIL A

Pull Cord Testing Hook

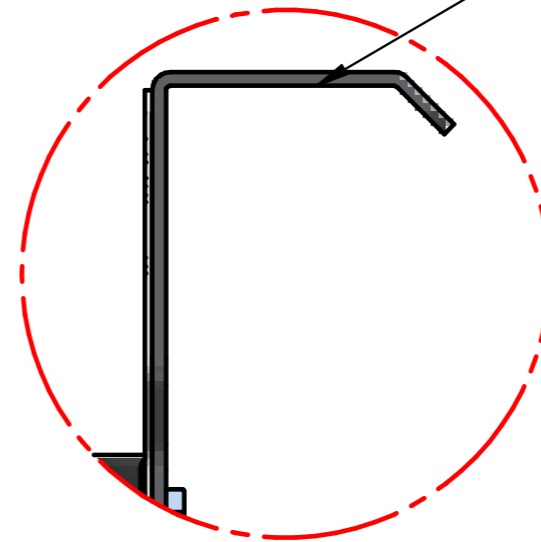

DETAIL B

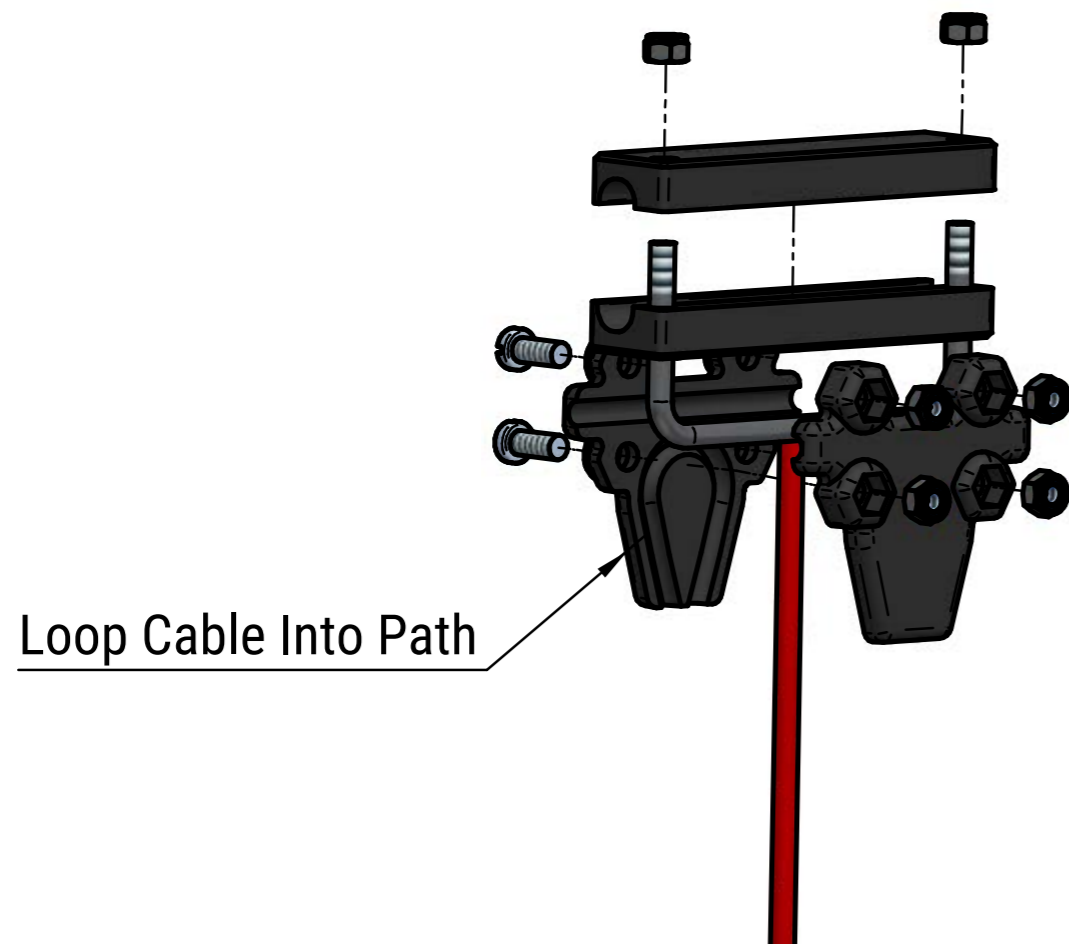
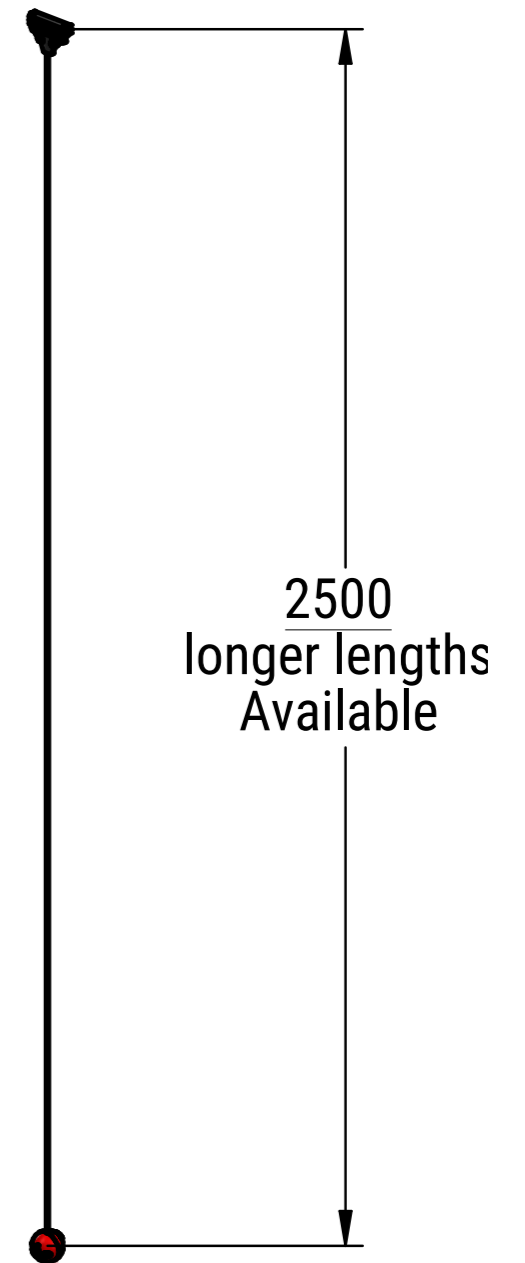
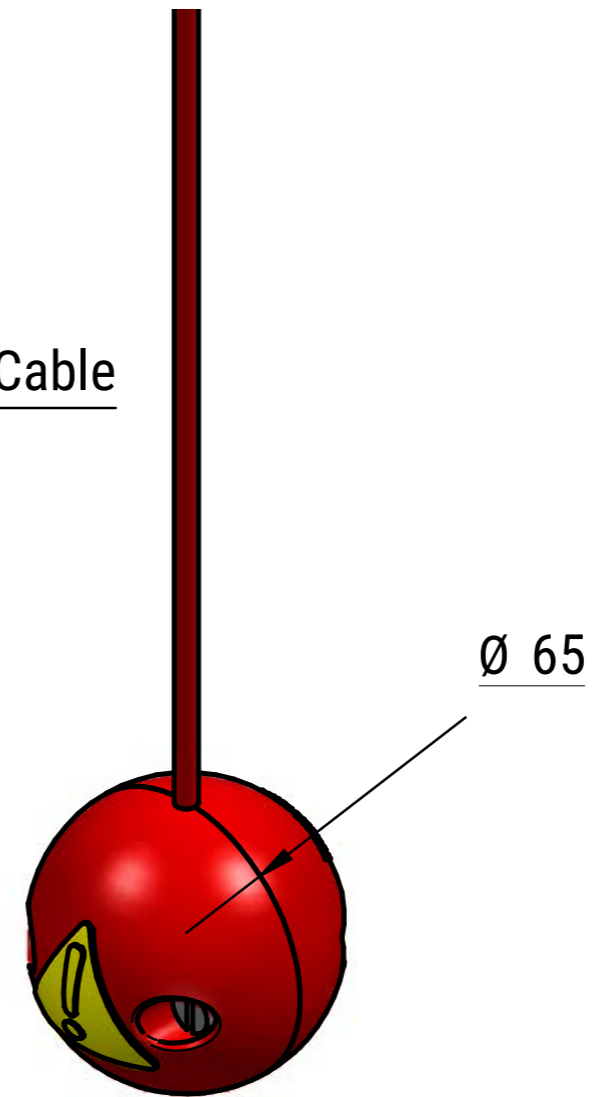
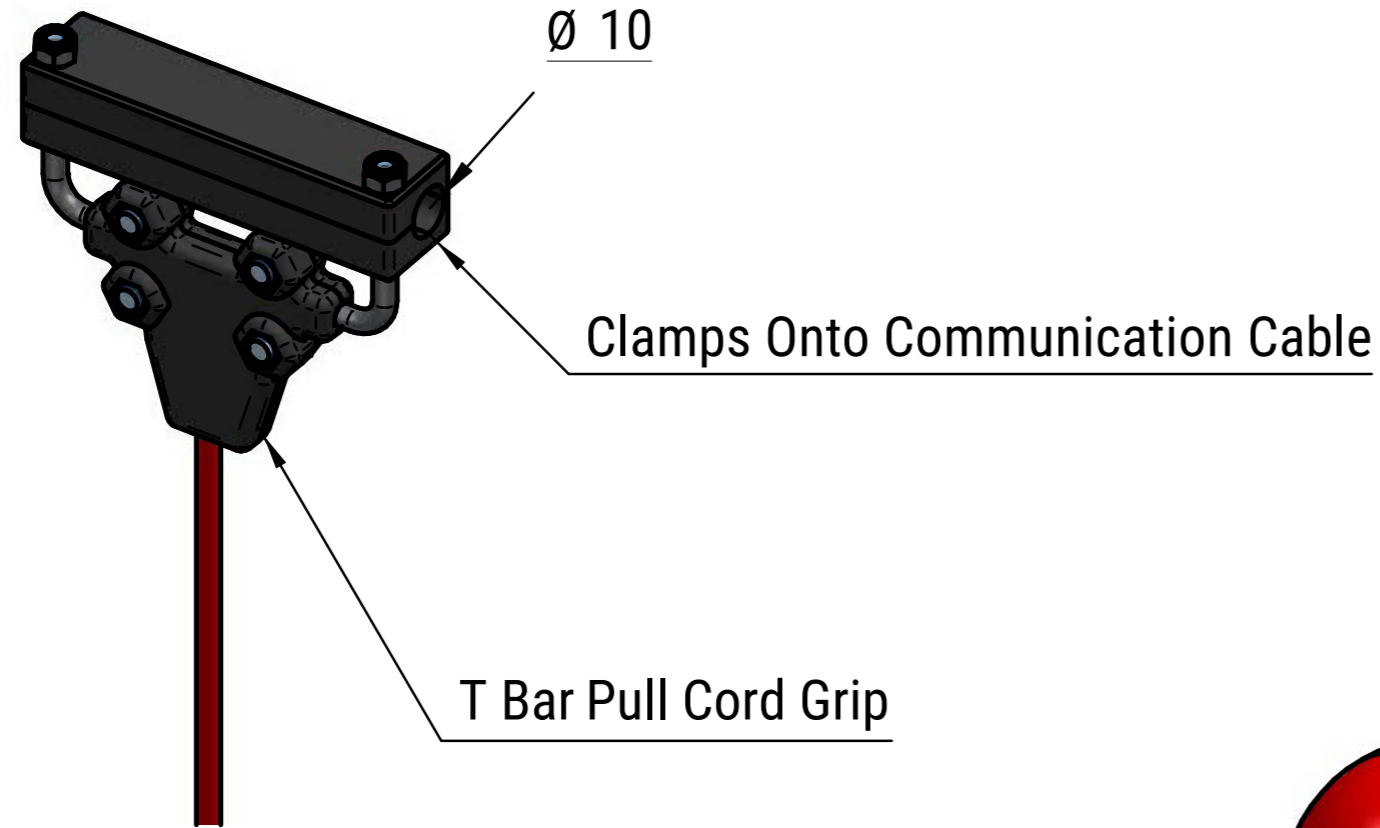

REPLACEMENT LID ALLOCATION STICKERS SAFE-T-PULL STAINLESS STEEL

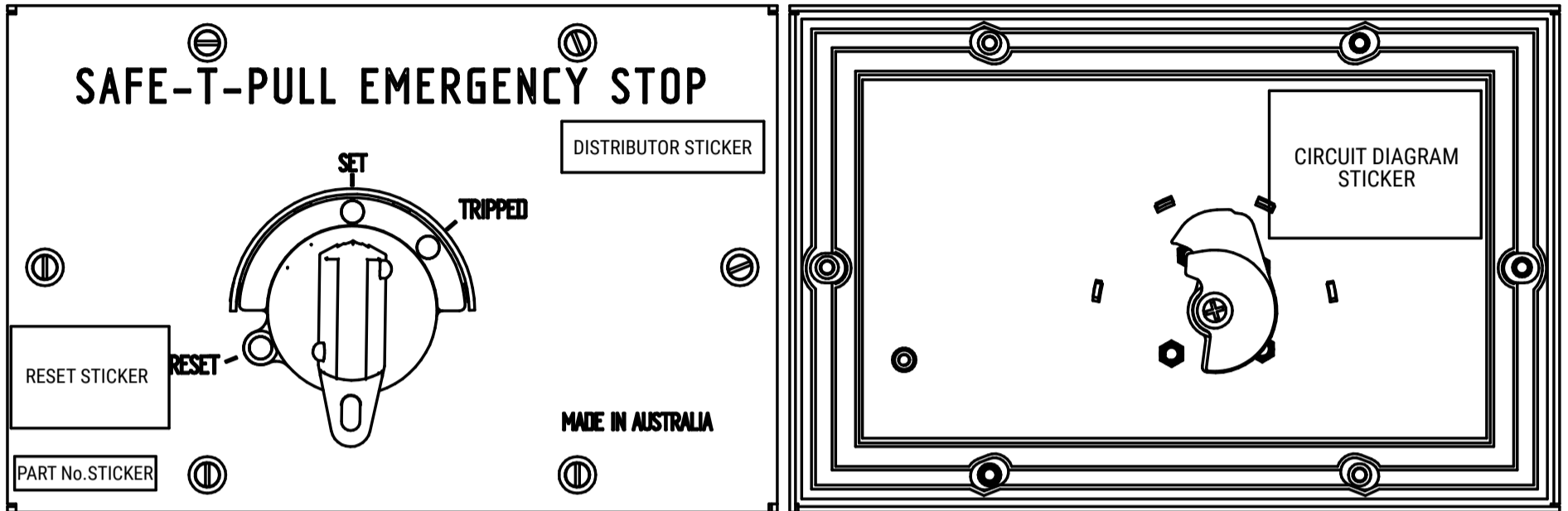

REPLACEMENT LID ALLOCATION STICKERS SAFE-T-PULL PC/PBT PLASTIC

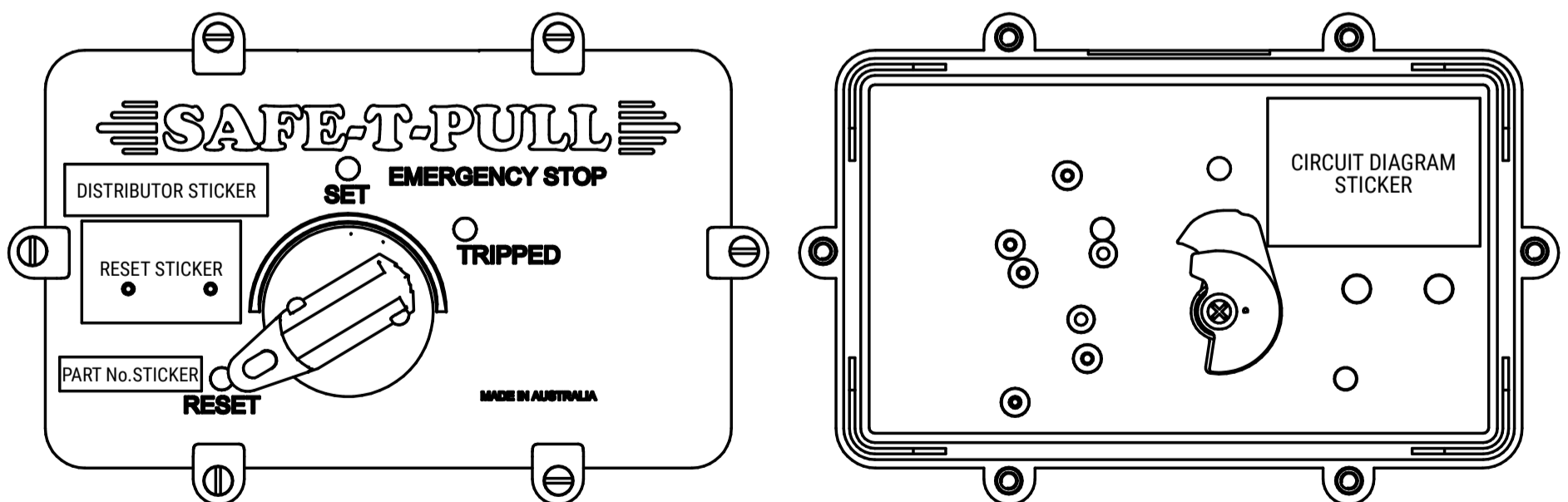

REPLACEMENT LID ALLOCATION STICKERS SAFE-T-PULL STAINLESS STEEL REMOTE ISOLATION

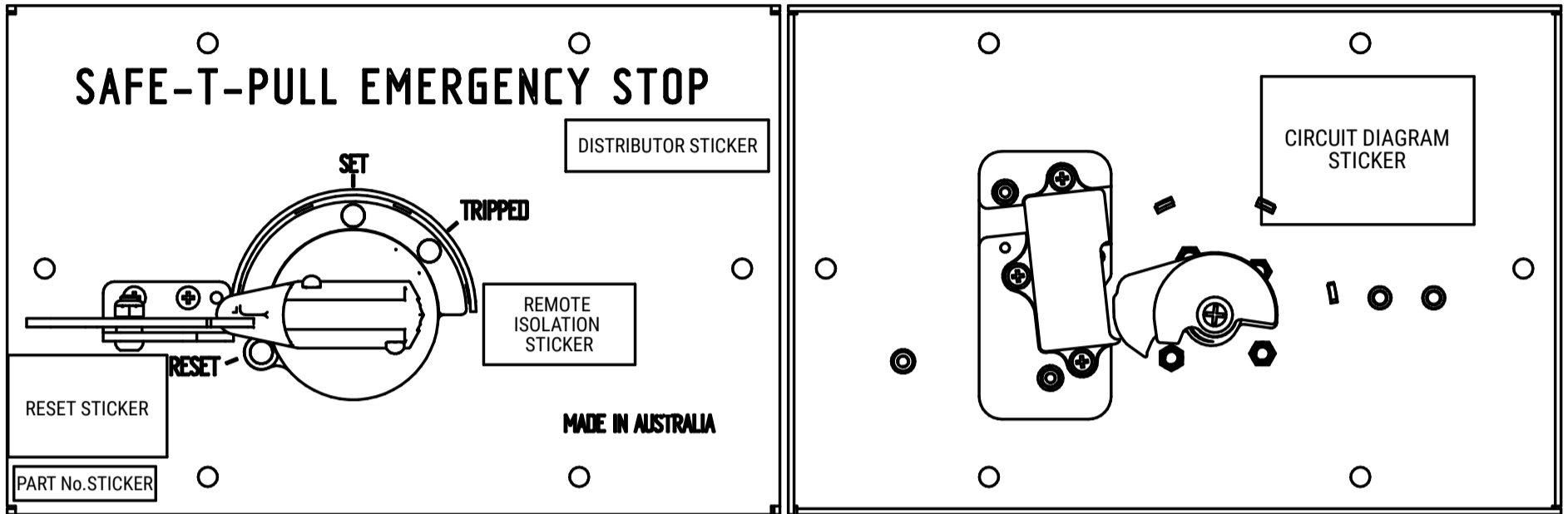

REPLACEMENT LID ALLOCATION STICKERS SAFE-T-PULL PC/PBT PLASTIC REMOTE ISOLATION

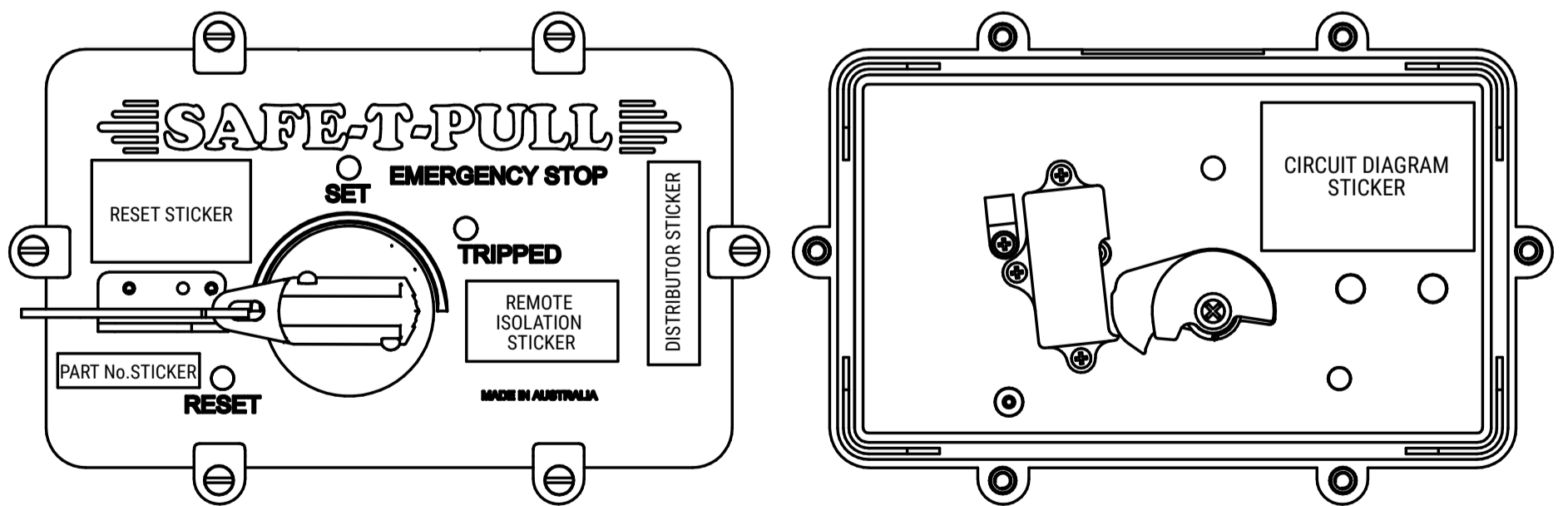

| | | | |
|---|----------------|--------------------------------------|----------------|
| CONVEYOR NUMBER: | | | |
| PULL CORD DEVICE LEFT HAND: | | PULL CORD DEVICE RIGHT HAND: | |
| Tick boxes for Yes (OK) or cross box for No (Check) | | | |
| TEST 1: AXIS PULL CORD TEST | | | |
| PULL CORD MOVES FREELY ON AXIS | | | |
| AWAY FROM DEVICE LEFT HAND | | | |
| AWAY FROM DEVICE RIGHT HAND | | | |
| TEST 2: 90 DEGREE PULL CORD TEST | | | |
| DEVICE LEFT HAND END | MIDDLE | DEVICE RIGHT HAND END | |
| Nm | Nm | Nm | |
| mm | mm | mm | |
| GENERAL PULL CORD SYSTEM INFORMATION | | | |
| PULL CORD NEEDED REPLACING | | | |
| PULL CORD TERMINATION NEEDS FIXING | | | |
| PULL CORD WIRING TERMINATION NEEDS FIXING | | | |
| GUIDE POSITION TOO CLOSE | | | |
| DEVICE LEFT HAND END Under 600mm | GENERAL <3M | DEVICE RIGHT HAND END Under 600mm | |
| | | | |
| GUIDE POSITION TOO FAR | | | |
| DEVICE LEFT HAND END Over 1m | GENERAL <4m | DEVICE RIGHT HAND END Over 1m | |
| | | | |
| DEFLECTIONS OVER 16 DEGREES | | | |
| STAIRCASE | | ROLLER GUIDE USED | |
| STAIRCASE | | ROLLER GUIDE USED | |
| PULL CORD INSTALLATION | | PULL CORD BEHIND STRUCTURE | |
| PULL CORD WEAR | NOTES | Please tick boxes under heading | |
| | | Behind Guard | Behind Objects |
| | | Not Accessible | |
| HIGH FRICTION POINTS | | | |
| PULL CORD STUCK | | | |
| PIGTAILS | | | |
| PULL CORD MOUNTED LOW > 900mm | | | |
| PULL CORD MOUNTED HIGH > 1500mm | | | |
| GUIDE REPLACE | | | |
| PIGTAIL - Conveyor Position No | | | |
| EYE BOLT - Conveyor Position No | | | |
| PULL CORD GUIDE - Conveyor Position No | | | |
| DEVICE REPLACEMENT | | | |
| DUST BOOT - Conveyor Position No | | | |
| LID - Conveyor Position No | | | |
| GENERAL - Conveyor Position No | | | |
| NOTE: | | | |
| | | | |
| | | | |