

# EMERGENCY STOP SAFETY DEVICE

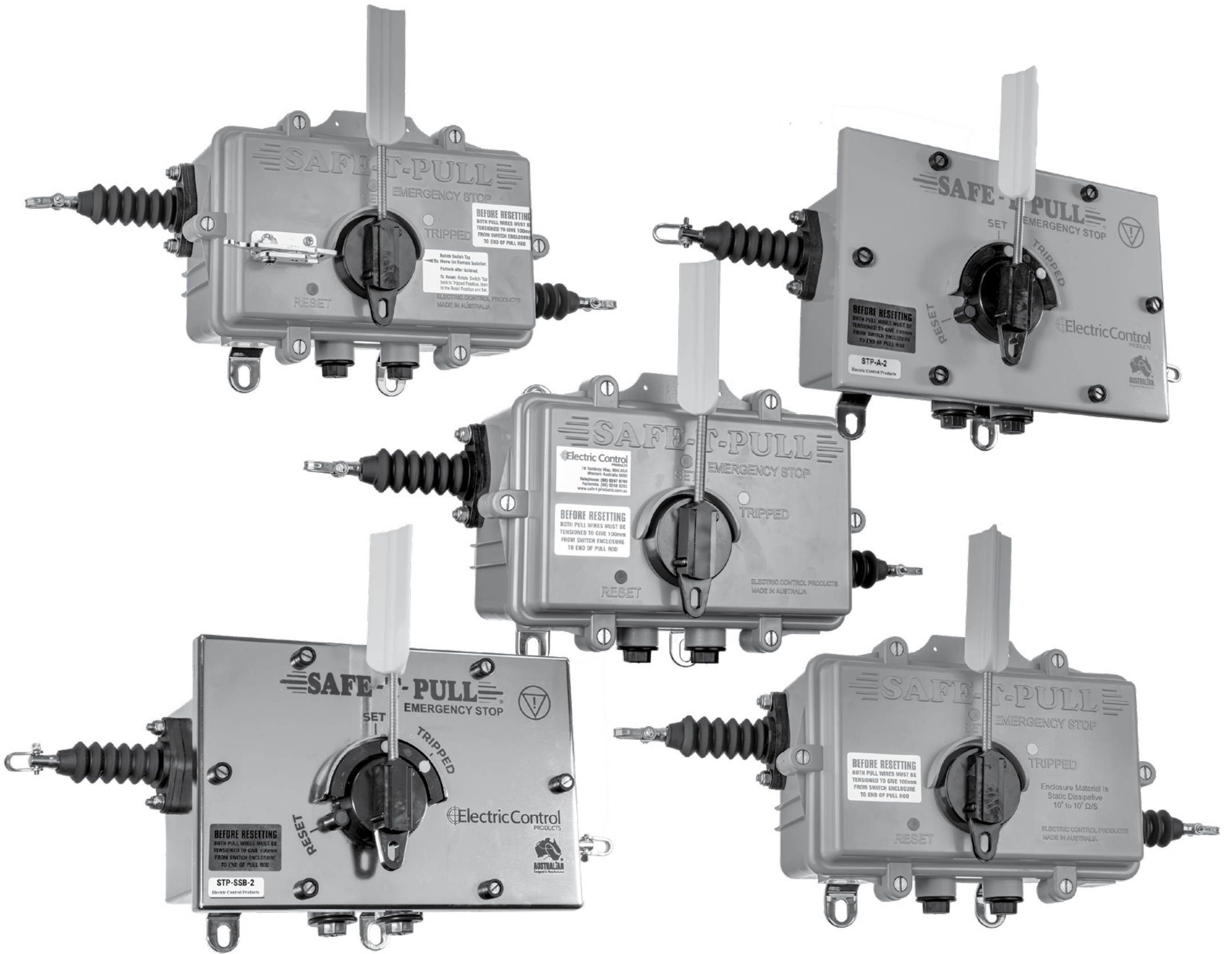

## TECHNICAL DOCUMENT

# INSTALLATION, DESIGN, SETTING INSTRUCTION AND TECHNICAL DOCUMENTATION

PLEASE VISIT OUR YOUTUBE CHANEL OR WEBSITE  
FOR MORE INFORMATION



FOR MORE INFORMATION

[www.safe-t-products.com.au](http://www.safe-t-products.com.au)



# SAFE-T-PULL

## TRADITIONAL INSTALLATION (STL-10-SS)

**NOT PREFERRED**

STP-P-\* STP-SD-\* STP-A-\* STP-SSB-\*

**YELLOW INDICATION FLAG:**

STP-F

The Indication Flag should be fitted when there is more than one device used on the conveyor as noted in AS4024.3610:2015 Clause 2.10.6.2 (e) **NOTE:**

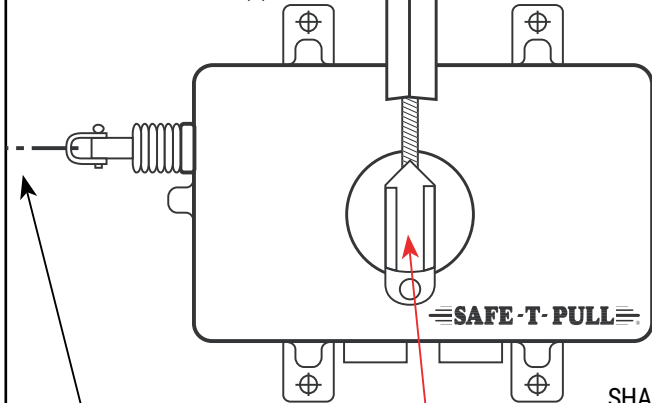

Use the same set up on the other side for dual direction device.

To reset the device via the device top only takes 1Nm. If a higher torque is felt, check device set point. IEC 60947-5-5 Clause 7.7.4

**NOTE:** After actuation and before resetting, the machinery shall be inspected along the whole length of the rope in order to detect the reason for activation. AS4024.1604 Clause 4.54

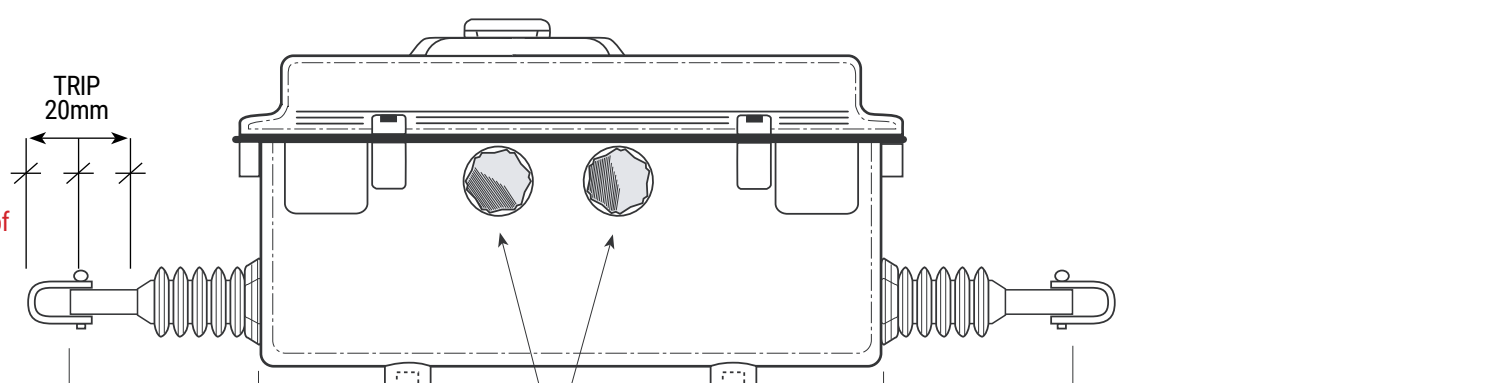
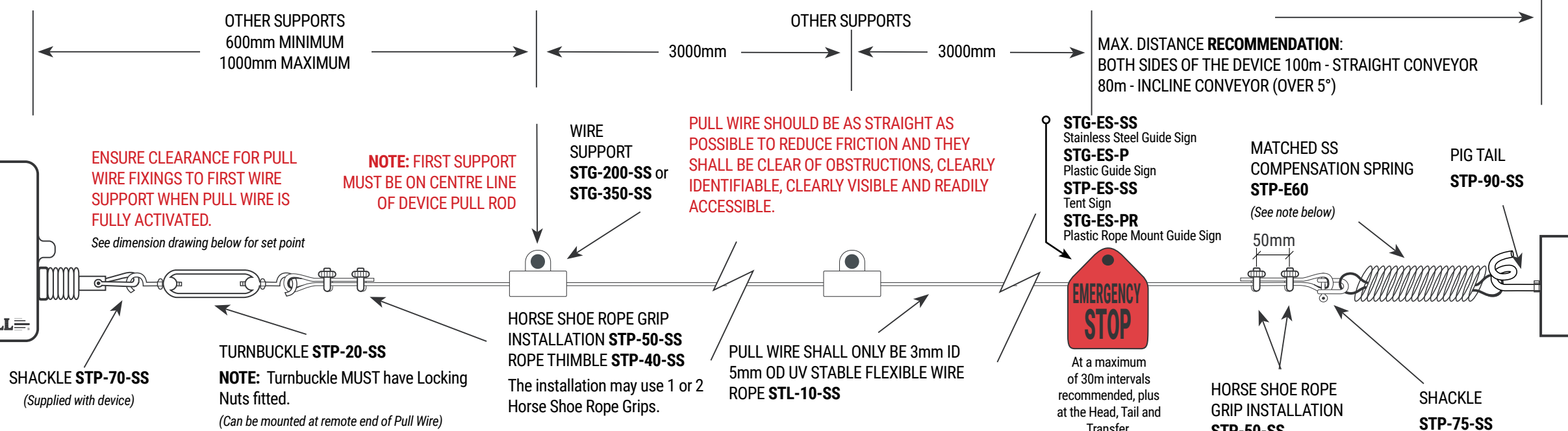
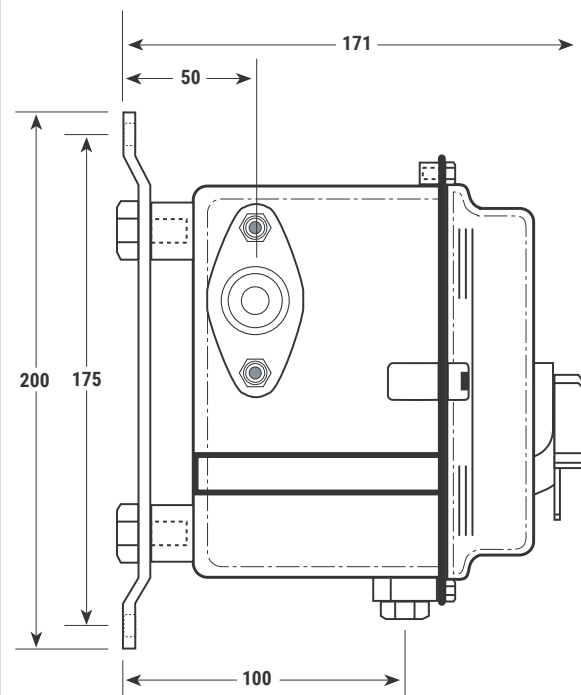

**DEVICE CANNOT BE RESET UNTIL BOTH PULL WIRES ARE CORRECTLY TENSIONED TO THE SET POSITION** ie. 100mm from pull rod end to device body.

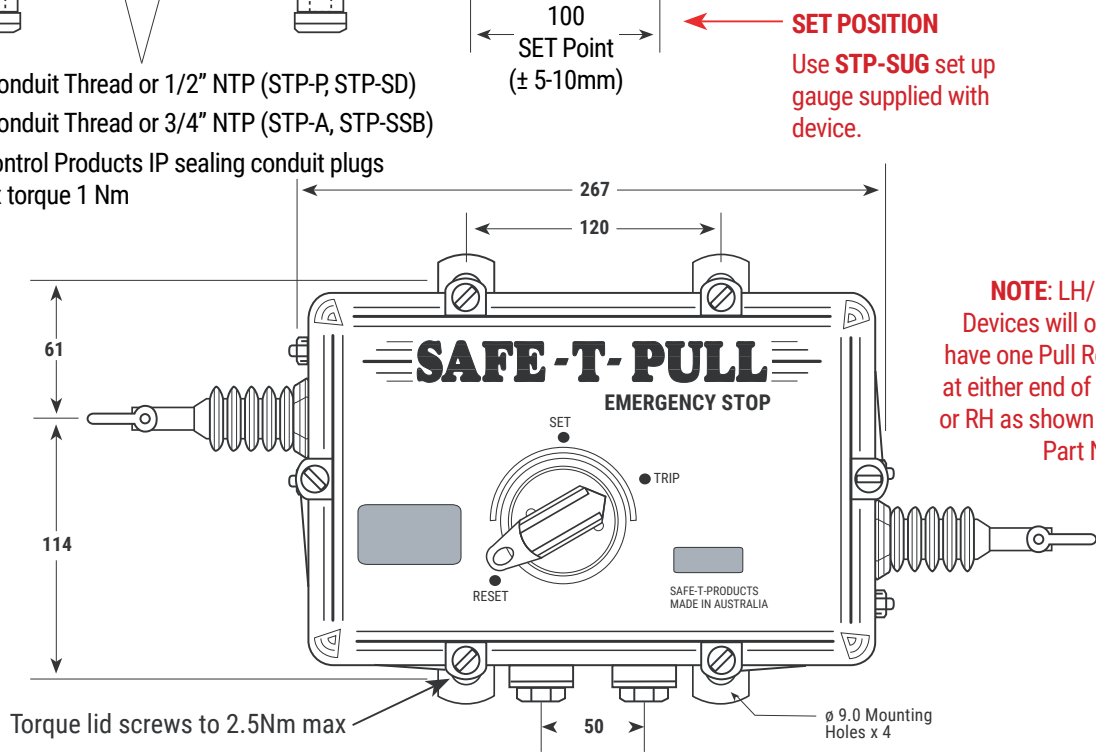

**NOTE:** Lanyards are to be fitted in front of removable guards, nip and shear points that are accessible on all bulk handling material conveyors and not to be replacements for guards.

**MAX. DISTANCE RECOMMENDATION:**  
BOTH SIDES OF THE DEVICE 100m - STRAIGHT CONVEYOR  
80m - INCLINE CONVEYOR (OVER 5°)

**PULL WIRE SHOULD BE AS STRAIGHT AS POSSIBLE TO REDUCE FRICTION AND THEY SHALL BE CLEAR OF OBSTRUCTIONS, CLEARLY IDENTIFIABLE, CLEARLY VISIBLE AND READILY ACCESSIBLE.**

**NOTE: FIRST SUPPORT MUST BE ON CENTRE LINE OF DEVICE PULL ROD**

**ENSURE CLEARANCE FOR PULL WIRE FIXINGS TO FIRST WIRE SUPPORT WHEN PULL WIRE IS FULLY ACTIVATED.**  
See dimension drawing below for set point

OTHER SUPPORTS  
600mm MINIMUM  
1000mm MAXIMUM

OTHER SUPPORTS

WIRE SUPPORT  
STG-200-SS or  
STG-350-SS

HORSE SHOE ROPE GRIP INSTALLATION STP-50-SS  
ROPE THIMBLE STP-40-SS  
The installation may use 1 or 2 Horse Shoe Rope Grips.

TURNBUCKLE STP-20-SS  
**NOTE:** Turnbuckle MUST have Locking Nuts fitted.  
(Can be mounted at remote end of Pull Wire)

SHACKLE STP-70-SS  
(Supplied with device)

STG-ES-SS Stainless Steel Guide Sign  
STG-ES-P Plastic Guide Sign  
STP-ES-SS Tent Sign  
STG-ES-PR Plastic Rope Mount Guide Sign

**EMERGENCY STOP**  
At a maximum of 30m intervals recommended, plus at the Head, Tail and Transfer.

MATCHED SS COMPENSATION SPRING STP-E60  
(See note below)

HORSE SHOE ROPE GRIP INSTALLATION STP-50-SS  
The installation may use 1 or 2 Horse Shoe Rope Grips.  
ROPE THIMBLE STP-40-SS

PIG TAIL STP-90-SS

SHACKLE STP-75-SS  
For shackle security "Mouse" the shackle after installation.

**SET POSITION**  
Use STP-SUG set up gauge supplied with device.

**NOTE: LH/RH**  
Devices will only have one Pull Rod, at either end of LH or RH as shown on Part No.

For further installation requirements refer to AS/NZS 4024-1-2014 Series: Safety of Machinery.

**NOTE:** To comply with the safety critical functions in AS/NZS 4024.3610 - 2015 Section 2.10.5 Emergency Stop. The locations of Pull Wires, components and elements to achieve the emergency stop function, person - on - conveyor stop, general requirements and Pull Wire design must all be reviewed before installation. In reviewing this, a balance matched compensation spring must be fitted to the remote ends of the taut wire system so that the system may work in all directions correctly. The SAFE-T-PULL device has its own balance matched compensation spring that will only work on this Electric Control Products device.

**NOTE:** These springs are tagged with a stainless steel label noting the compliance. Other branded devices must have their own compensation spring used. They should be balance matched to the internal spring system so the Pull Wire system is still functioning as a safety critical system and meets the requirements of the standards.





# SAFE-T-PULL

## STAINLESS STEEL ROPE QUICK INSTALLATION (STL-10-SS)

**PREFERRED**

STP-P-\* STP-SD-\* STP-A-\* STP-SSB-\*

**YELLOW INDICATION FLAG:**

STP-F

The Indication Flag should be fitted when there is more than one device used on the conveyor as noted in AS4024.3610:2015 Clause 2.10.6.2 (e) **NOTE:**

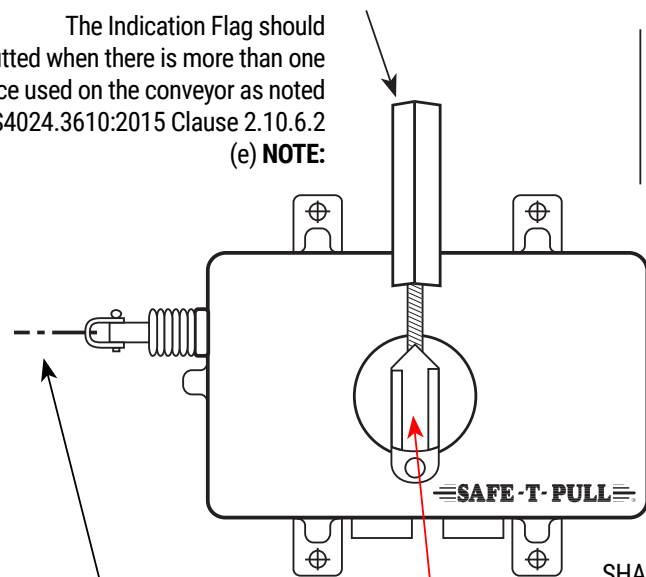

Use the same set up on the other side for dual direction device.

To reset the device via the device top only takes 1Nm. If a higher torque is felt, check device set point. IEC 60947-5-5 Clause 7.7.4

**NOTE:** After actuation and before resetting, the machinery shall be inspected along the whole length of the rope in order to detect the reason for activation. AS4024.1604 Clause 4.54

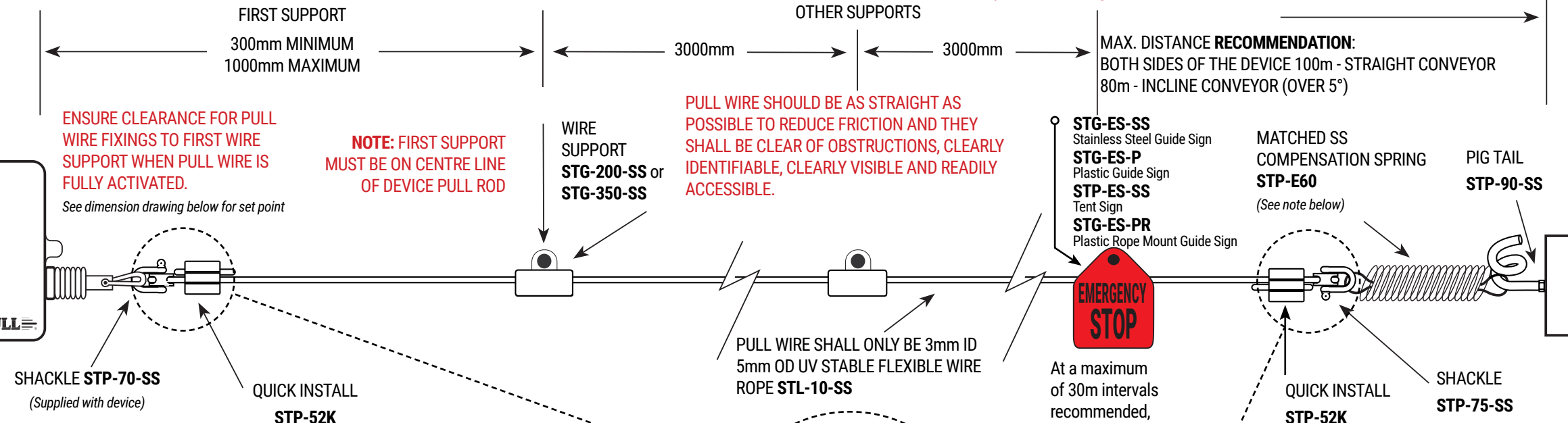
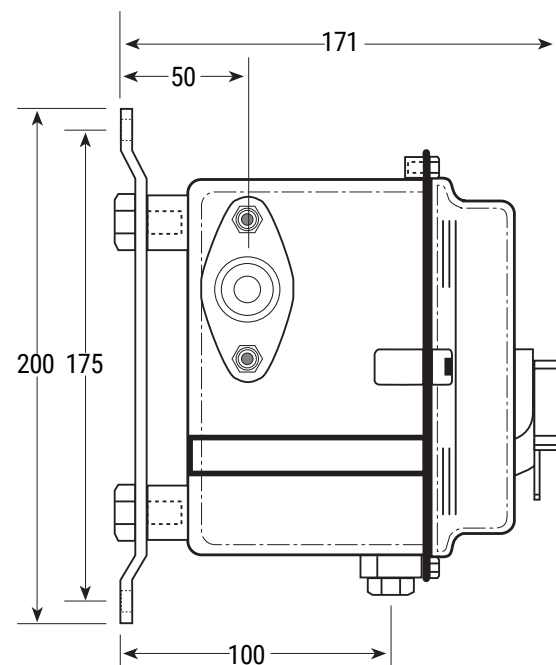

**NOTE:** Lanyards are to be fitted in front of removable guards, nip and shear points that are accessible on all bulk handling material conveyors and not to be replacements for guards.

**MAX. DISTANCE RECOMMENDATION:**  
BOTH SIDES OF THE DEVICE 100m - STRAIGHT CONVEYOR  
80m - INCLINE CONVEYOR (OVER 5°)

ENSURE CLEARANCE FOR PULL WIRE FIXINGS TO FIRST WIRE SUPPORT WHEN PULL WIRE IS FULLY ACTIVATED.  
See dimension drawing below for set point

**NOTE:** FIRST SUPPORT MUST BE ON CENTRE LINE OF DEVICE PULL ROD

WIRE SUPPORT  
STG-200-SS or  
STG-350-SS

PULL WIRE SHOULD BE AS STRAIGHT AS POSSIBLE TO REDUCE FRICTION AND THEY SHALL BE CLEAR OF OBSTRUCTIONS, CLEARLY IDENTIFIABLE, CLEARLY VISIBLE AND READILY ACCESSIBLE.

STG-ES-SS  
Stainless Steel Guide Sign  
STG-ES-P  
Plastic Guide Sign  
STP-ES-SS  
Tent Sign  
STG-ES-PR  
Plastic Rope Mount Guide Sign

MATCHED SS COMPENSATION SPRING  
STP-E60  
(See note below)

PIG TAIL  
STP-90-SS

PULL WIRE SHALL ONLY BE 3mm ID  
5mm OD UV STABLE FLEXIBLE WIRE  
ROPE STL-10-SS

At a maximum of 30m intervals recommended, plus at the Head, Tail and Transfer.

QUICK INSTALL  
STP-52K

SHACKLE  
STP-75-SS  
For shackle security "Mouse" the shackle after installation.

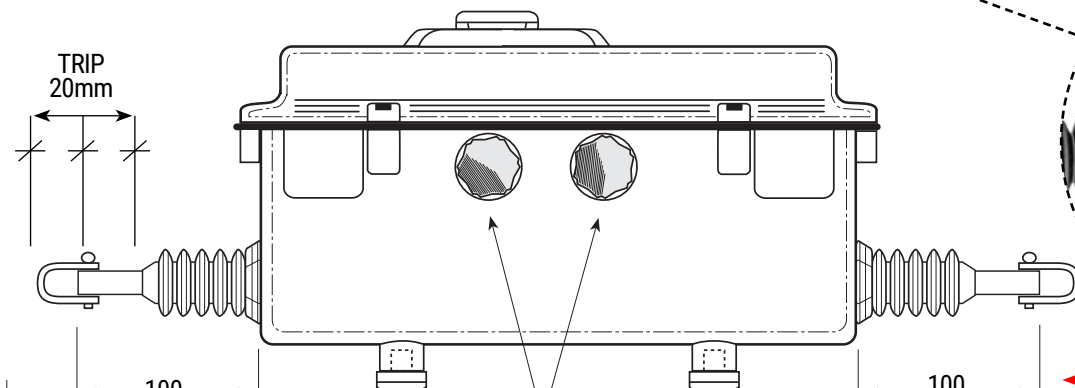

**DEVICE CANNOT BE RESET UNTIL BOTH PULL WIRES ARE CORRECTLY TENSIONED TO THE SET POSITION**  
ie. 100mm from pull rod end to device body.

**SET POSITION**  
Use STP-SUG set up gauge supplied with device.

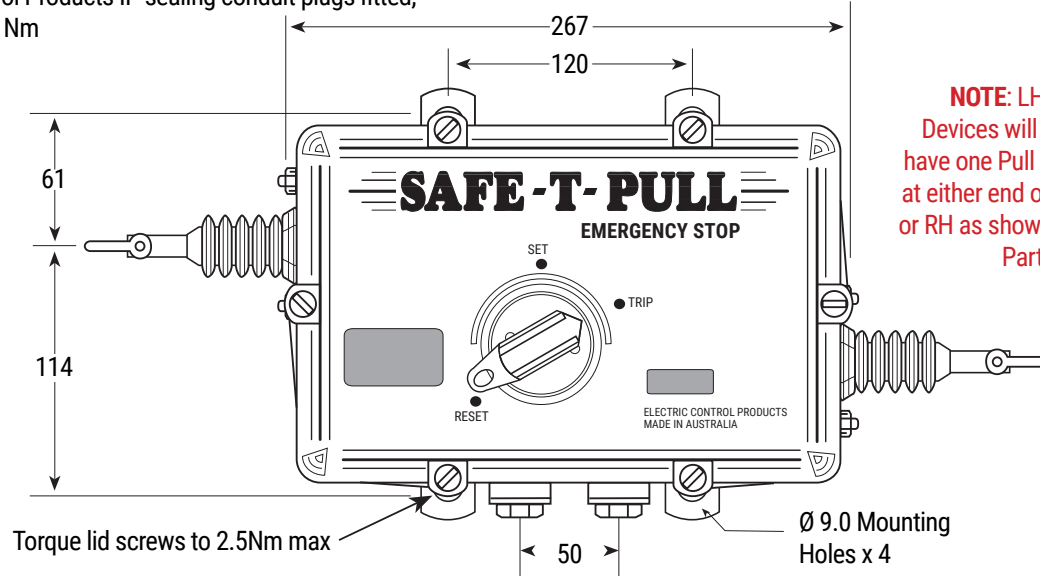

**NOTE:** LH/RH Devices will only have one Pull Rod, at either end of LH or RH as shown on Part No.

For further installation requirements refer to AS/NZS 4024-1-2014 Series: Safety of Machinery.

**NOTE:** To comply with the safety critical functions in AS/NZS 4024.3610 - 2015 Section 2.10.5 Emergency Stop. The locations of Pull Wires, components and elements to achieve the emergency stop function, person - on - conveyor stop, general requirements and Pull Wire design must all be reviewed before installation. In reviewing this, a balance matched compensation spring must be fitted to the remote ends of the taut wire system so that the system may work in all directions correctly. The SAFE-T-PULL device has its own balance matched compensation spring that will only work on this Electric Control Products device.

**NOTE:** These springs are tagged with a stainless steel label noting the compliance. Other branded devices must have their own compensation spring used. They should be balance matched to the internal spring system so the Pull Wire system is still functioning as a safety critical system and meets the requirements of the standards.

# SAFE-T-PULL

## VECTRAN ROPE QUICK INSTALLATION (STL-10-V)

**PREFERRED**

STP-P STP-SD STP-A STP-SSB

**YELLOW INDICATION FLAG:**

STP-F

The Indication Flag should be fitted when there is more than one device used on the conveyor as noted in AS4024.3610:2015 Clause 2.10.6.2 (e) **NOTE:**

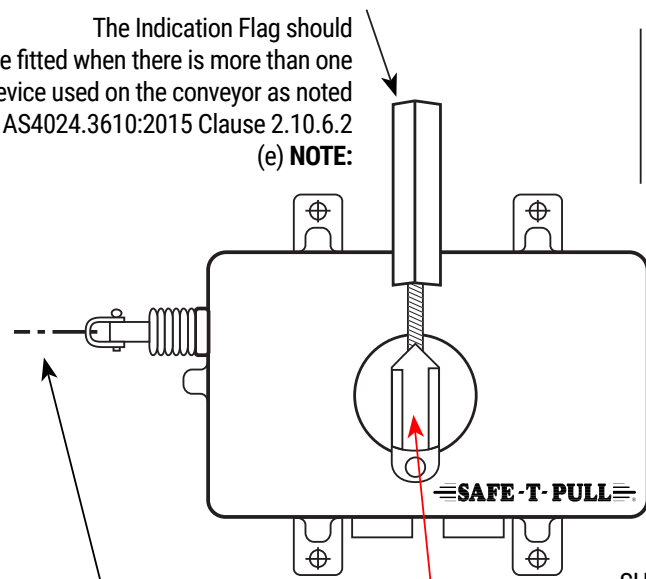

Use the same set up on the other side for dual direction device.

To reset the device via the device top only takes 1Nm. If a higher torque is felt, check device set point. IEC 60947-5-5 Clause 7.7.4

**NOTE:** After actuation and before resetting, the machinery shall be inspected along the whole length of the rope in order to detect the reason for activation. AS4024.1604 Clause 4.54

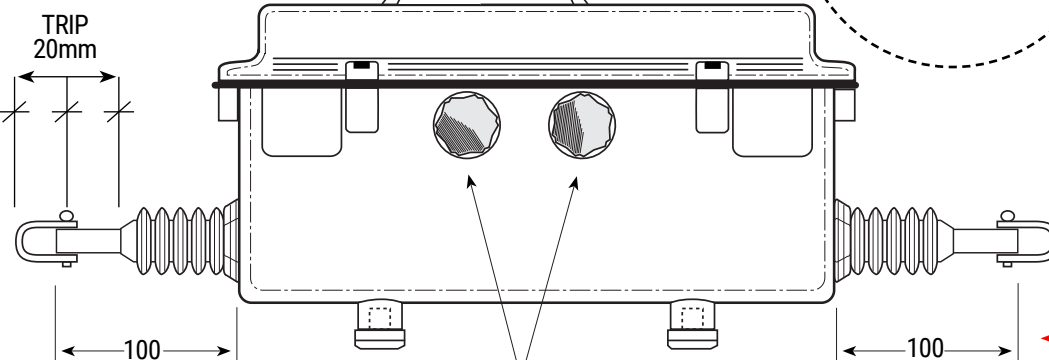
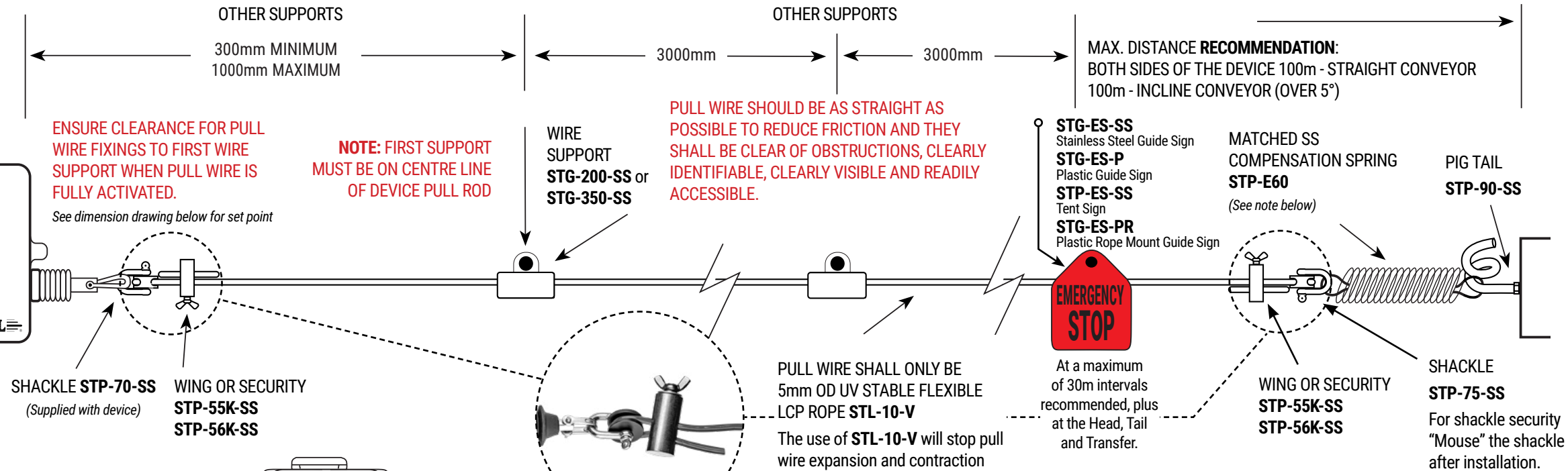
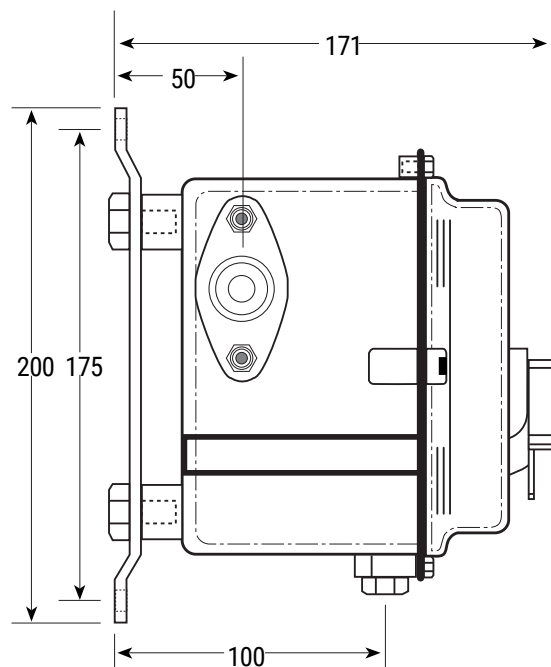

**DEVICE CANNOT BE RESET UNTIL BOTH PULL WIRES ARE CORRECTLY TENSIONED TO THE SET POSITION**  
ie. 100mm from pull rod end to device body.

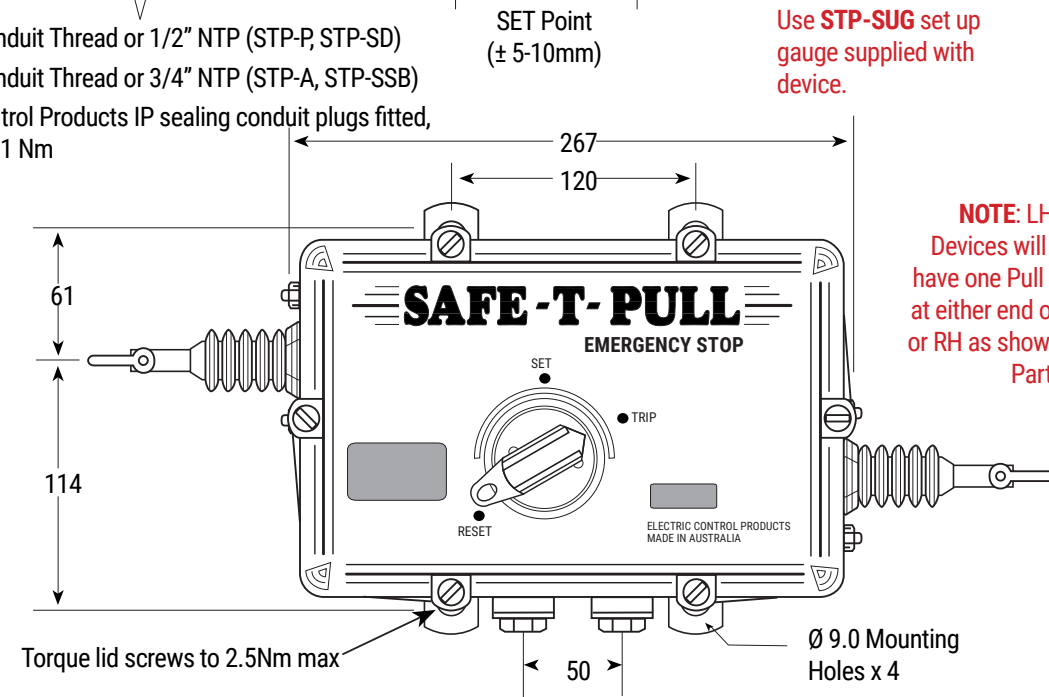

For further installation requirements refer to AS/NZS 4024-1-2014 Series: Safety of Machinery.

**NOTE:** To comply with the safety critical functions in AS/NZS 4024.3610 - 2015 Section 2.10.5 Emergency Stop. The locations of Pull Wires, components and elements to achieve the emergency stop function, person - on - conveyor stop, general requirements and Pull Wire design must all be reviewed before installation. In reviewing this, a balance matched compensation spring must be fitted to the remote ends of the taut wire system so that the system may work in all directions correctly. The SAFE-T-PULL device has its own balance matched compensation spring that will only work on this Electric Control Products device.

**NOTE:** These springs are tagged with a stainless steel label noting the compliance. Other branded devices must have their own compensation spring used. They should be balance matched to the internal spring system so the Pull Wire system is still functioning as a safety critical system and meets the requirements of the standards.



# SAFE-T-PULL

## STP SLACK WIRE SETUP

**NOT PREFERRED**

### STP-P-2-NT & STP-P-4-NT

#### YELLOW INDICATION FLAG:

**STP-F**  
The Indication Flag should be fitted when there is more than one device used on the conveyor as noted in AS4024.3610:2015 Clause 2.10.6.2 (e) **NOTE:**

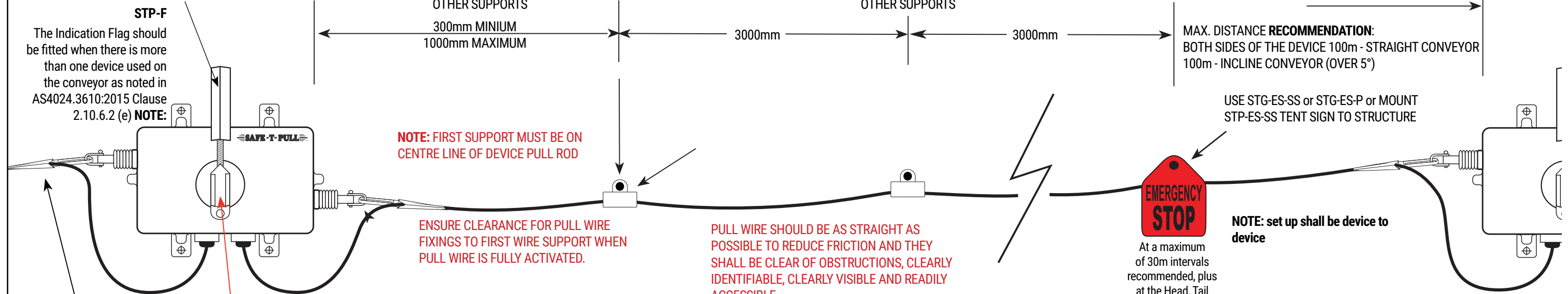

**NOTE: FIRST SUPPORT MUST BE ON CENTRE LINE OF DEVICE PULL ROD**

**ENSURE CLEARANCE FOR PULL WIRE FIXINGS TO FIRST WIRE SUPPORT WHEN PULL WIRE IS FULLY ACTIVATED.**

**PULL WIRE SHOULD BE AS STRAIGHT AS POSSIBLE TO REDUCE FRICTION AND THEY SHALL BE CLEAR OF OBSTRUCTIONS, CLEARLY IDENTIFIABLE, CLEARLY VISIBLE AND READILY ACCESSIBLE.**



At a maximum of 30m intervals recommended, plus at the Head, Tail and Transfer.

USE STG-ES-SS or STG-ES-P or MOUNT STP-ES-SS TENT SIGN TO STRUCTURE

**NOTE: set up shall be device to device**

Use the same set up on the other side for dual direction device.

To reset the device via the device top only takes 1Nm. If a higher torque is felt, check device set point. IEC 60947-5-5 Clause 7.7.4

**NOTE: After actuation and before resetting, the machinery shall be inspected along the whole length of the rope in order to detect the reason for activation. AS4024.1604 Clause 4.54**

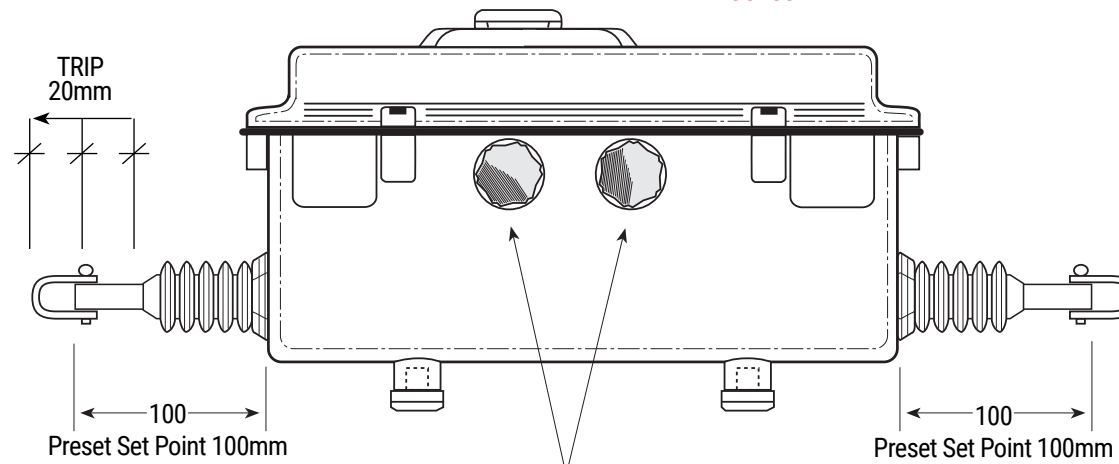

2 x m20 Conduit Thread or 1/2" NTP (STP-P, STP-SD)  
2 x m25 Conduit Thread or 3/4" NTP (STP-A, STP-SSB)  
Electric Control Products IP sealing conduit plugs fitted,  
Max torque 1 Nm

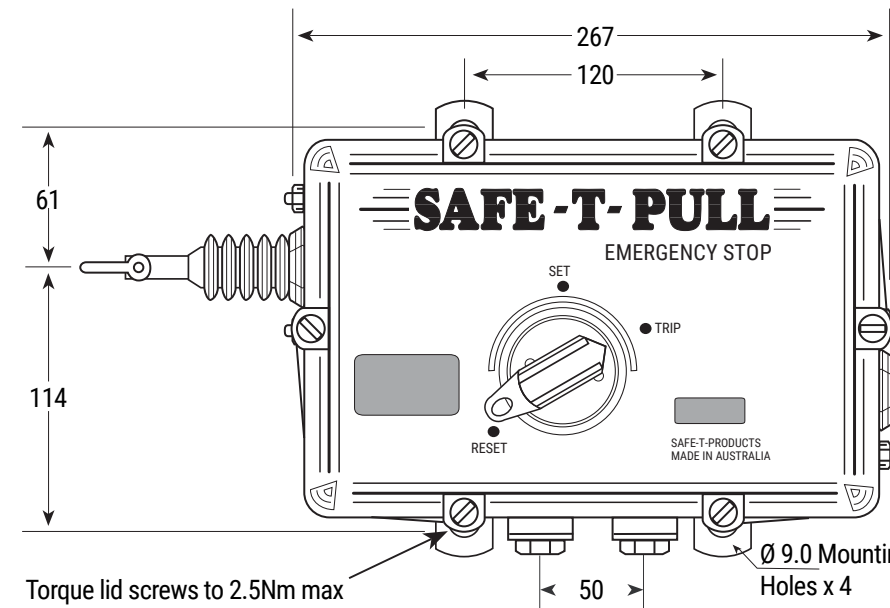
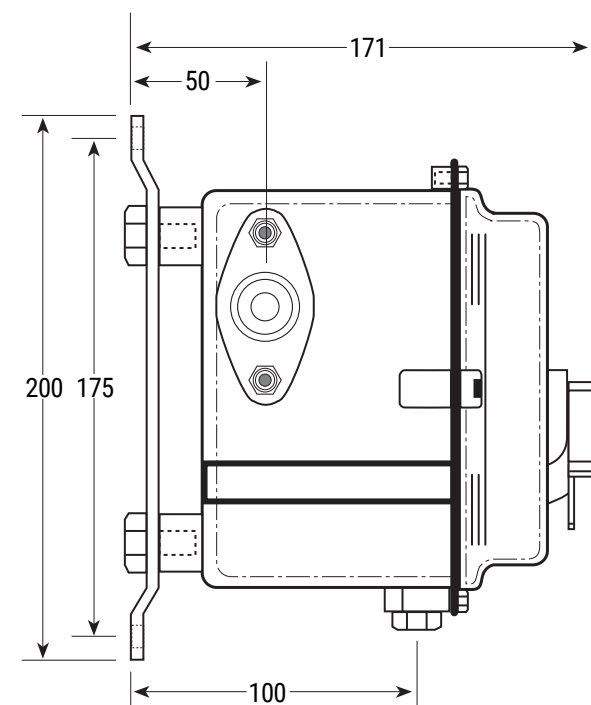

For further installation requirements refer to AS/NZS 4024-1-2014 Series: Safety of Machinery.

**NOTE: To comply with the safety critical functions in AS/NZS 4024.3610 - 2015 Section 2.10.5 Emergency Stop. The locations of Pull Wires, components and elements to achieve the emergency stop function, person - on - conveyor stop, general requirements and Pull Wire design must all be reviewed before installation.**



**NOTE: LH/RH Devices will only have one Pull Rod, at either end of LH or RH as shown on Part No.**



## RESETTING DIAGRAMS

**TENSION DEVICE DUAL**  
MUST USE PULL WIRE  
**DUAL SIDED OPERATION TYPE**

PULL OUT RODS & KEEP AT 100mm, THEN RESET VIA DIAL. ECPGS-027





Scan QR Code for reset & trip details ↑

**STP-P, -SD, -A, -SSB**

**SLACK/NON TENSION DEVICE DUAL**  
MUST USE MONITORED LANYARD  
**DUAL SIDED OPERATION TYPE**

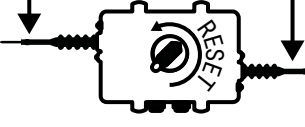
RODS IN PRESET POSITION ECPGS-028





Scan QR Code for reset & trip details ↑

**STP-P-NT, -SD-NT, -A-NT, -SSB-NT**

**TENSION DEVICE RIGHT HAND**  
MUST USE PULL WIRE  
**SINGLE SIDED OPERATION TYPE**

PULL OUT ROD & KEEP AT 100mm, THEN RESET VIA DIAL. ECPGS-027-A





Scan QR Code for reset & trip details ↑

**STP-P-RH, -SD-RH, -A-RH, -SSB-RH**

**SLACK/NON TENSION DEVICE RIGHT**  
MUST USE MONITORED LANYARD  
**RIGHT HAND OPERATION TYPE**

ROD IN PRESET POSITION ECPGS-028-A





Scan QR Code for reset & trip details ↑

**STP-P-NT-RH, -SD-NT-RH, -A-NT-RH, -SSB-NT-RH**

**TENSION DEVICE LEFT HAND**  
MUST USE PULL WIRE  
**SINGLE SIDED OPERATION TYPE**

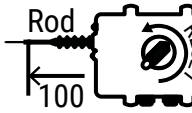
PULL OUT ROD & KEEP AT 100mm, THEN RESET VIA DIAL. ECPGS-027-B





Scan QR Code for reset & trip details ↑

**STP-P-LH, -SD-LH, -A-LH, -SSB-LH**

**SLACK/NON TENSION DEVICE LEFT**  
MUST USE MONITORED LANYARD  
**LEFT HAND OPERATION TYPE**

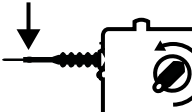
ROD IN PRESET POSITION ECPGS-028-B





Scan QR Code for reset & trip details ↑

**STP-P-NT-LH, -SD-NT-LH, -A-NT-LH, -SSB-NT-LH**

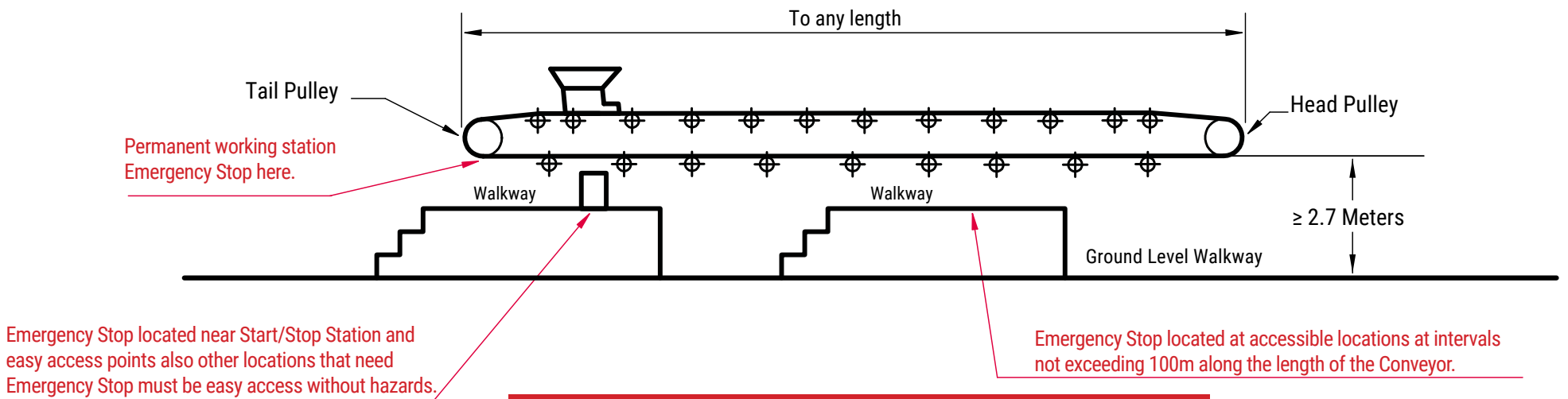
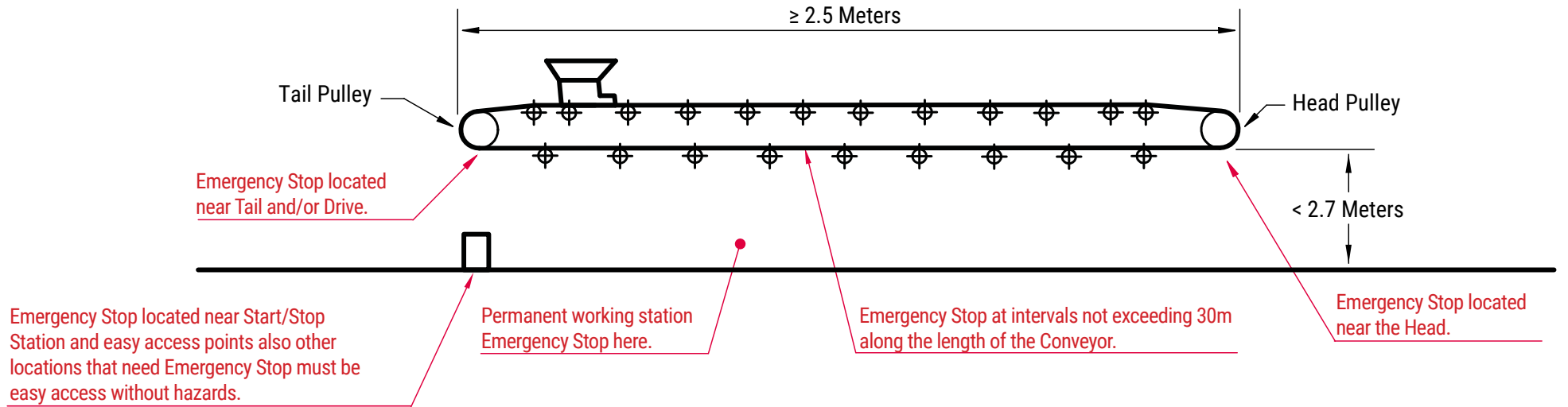
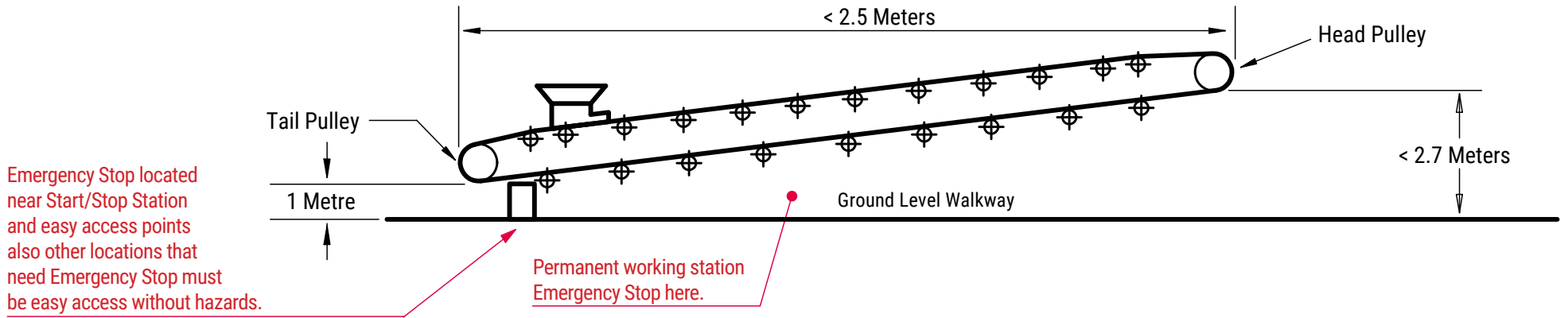

## BULK HANDLING MATERIAL CONVEYORS: LOCATION OF EMERGENCY STOPS



**NOTE:** Consideration shall be given for the provision of an emergency stop at the take-up where the take-up is on another level or remote from the main drive.

### DEFLECTIONS - PULL WIRE SETUP

**NOTE:** Keep deflections to a minimum angle and as least as possible.

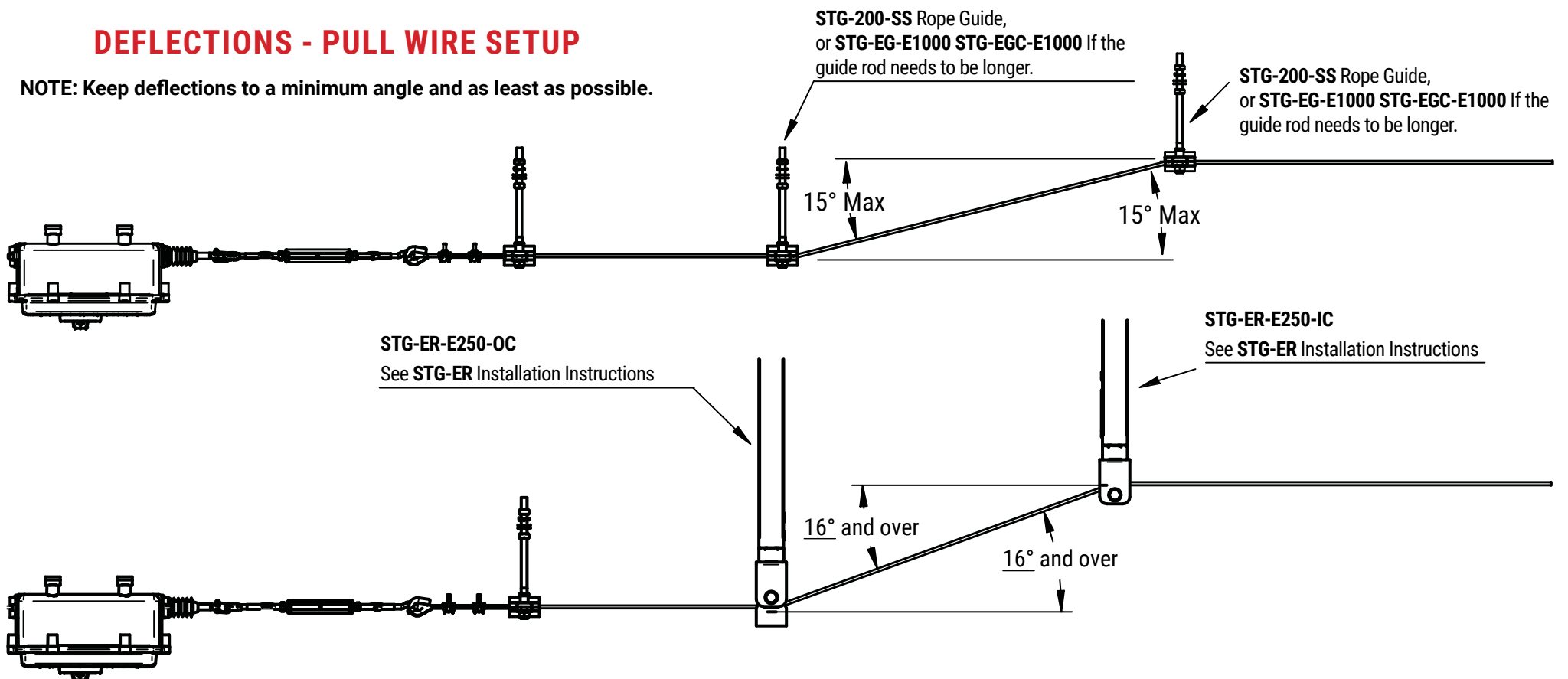

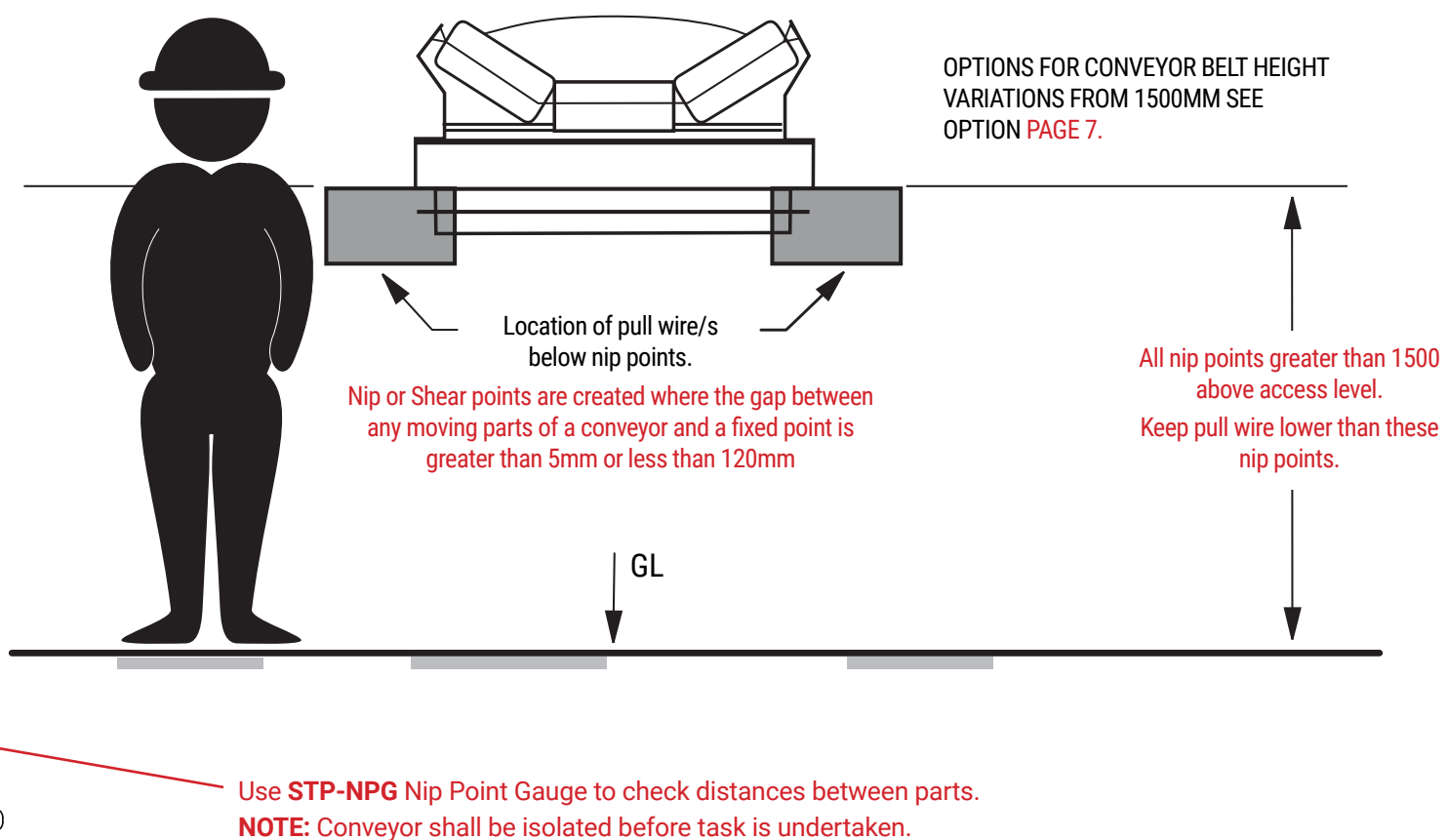
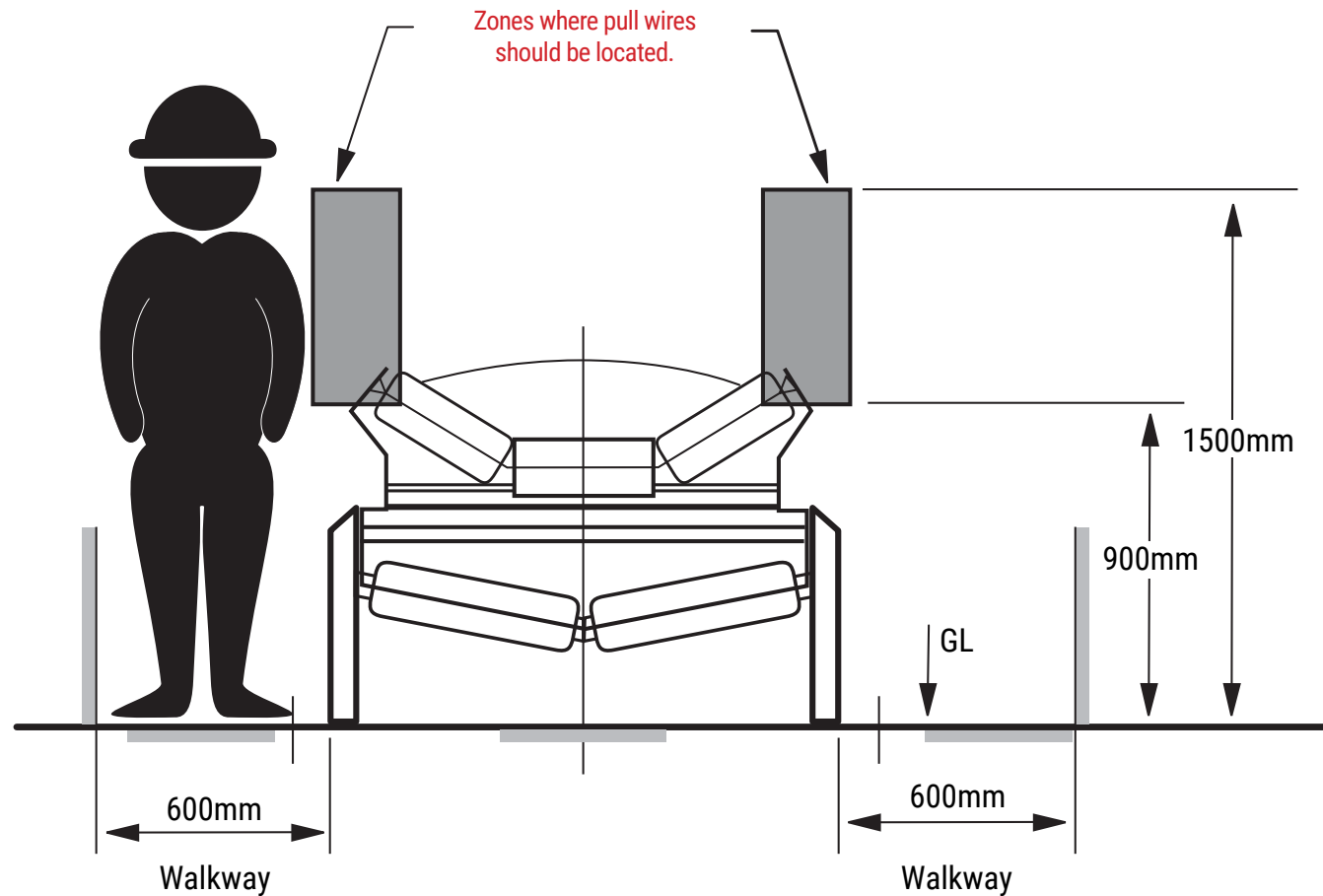

## LOCATIONS OF PULL WIRES

The design risk assessment shall determine the most favourable location for the pull wire systems location.

Where practicable, pull wires should be in such a manner that they are, clearly visible, adding signs or colour of pull wires can help. Readily accessible for any personnel that potentially may become trapped in a danger area or any personnel that may be nearby. Outside any readily removable guard and external to the vertical line of any nip or shear point. They should be no further than 1m from the nip or shear point.

At least 900mm above the access floor. Should be no more than 1500mm above the access floor. Where required to be higher than 1500mm, the pull wire system should be located lower than the nip or shear points.

Also, the consideration of the potential for a person to inadvertently be on a moving conveyor, the severity of injury to a person due to this event and whether a risk control needs to be in place.

ELECTRIC CONTROL PRODUCTS recommends the "Collide Safe" Man-On-Belt device for this application.



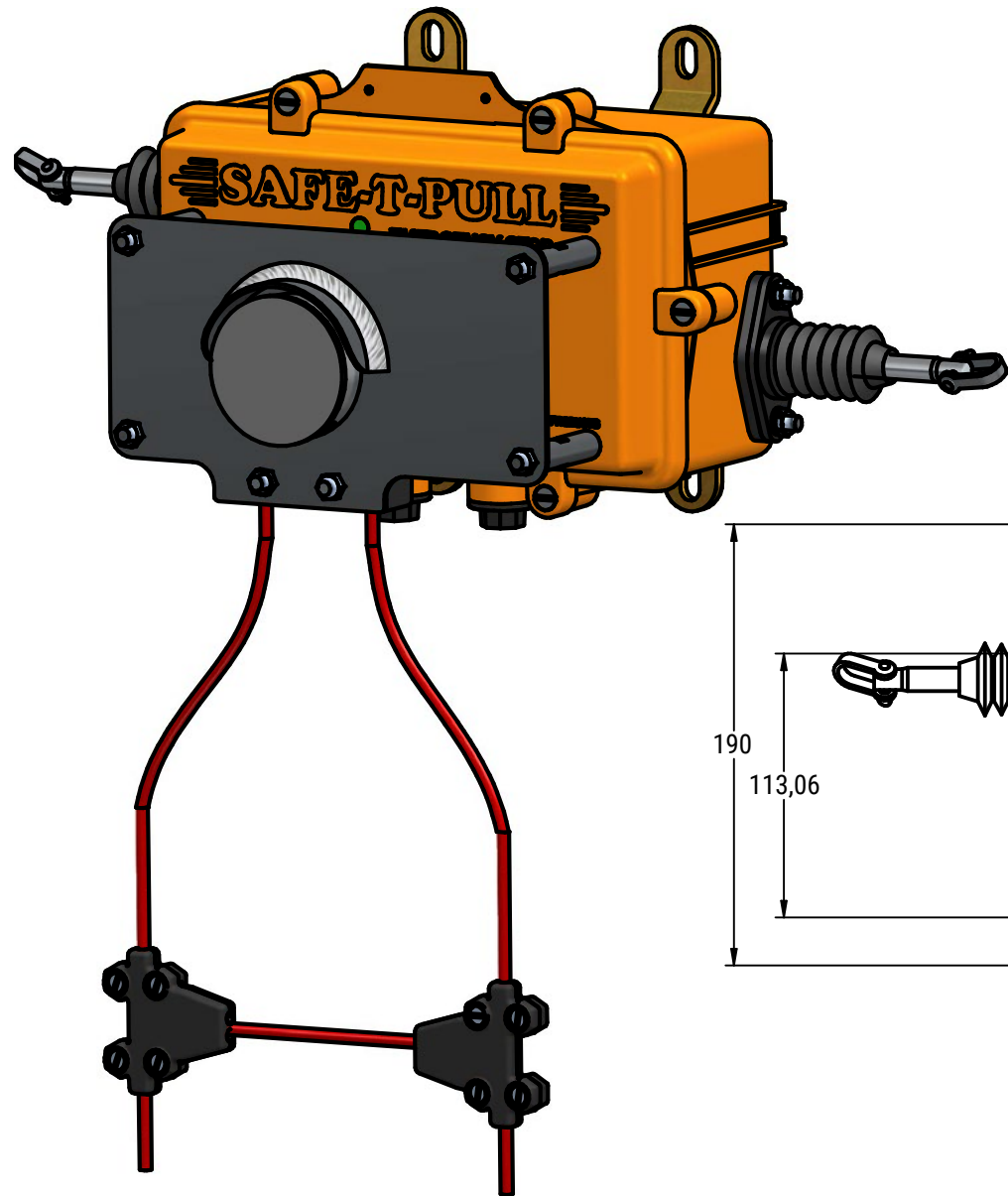

ADJUSTABLE LENGTH PULL CORDS

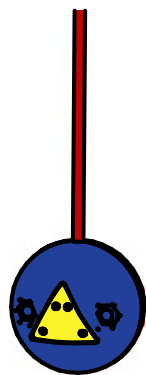

RESET BALL

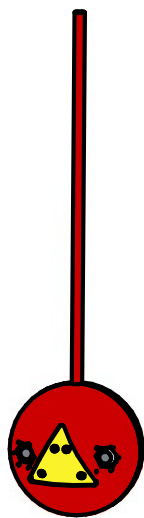

TRIP BALL

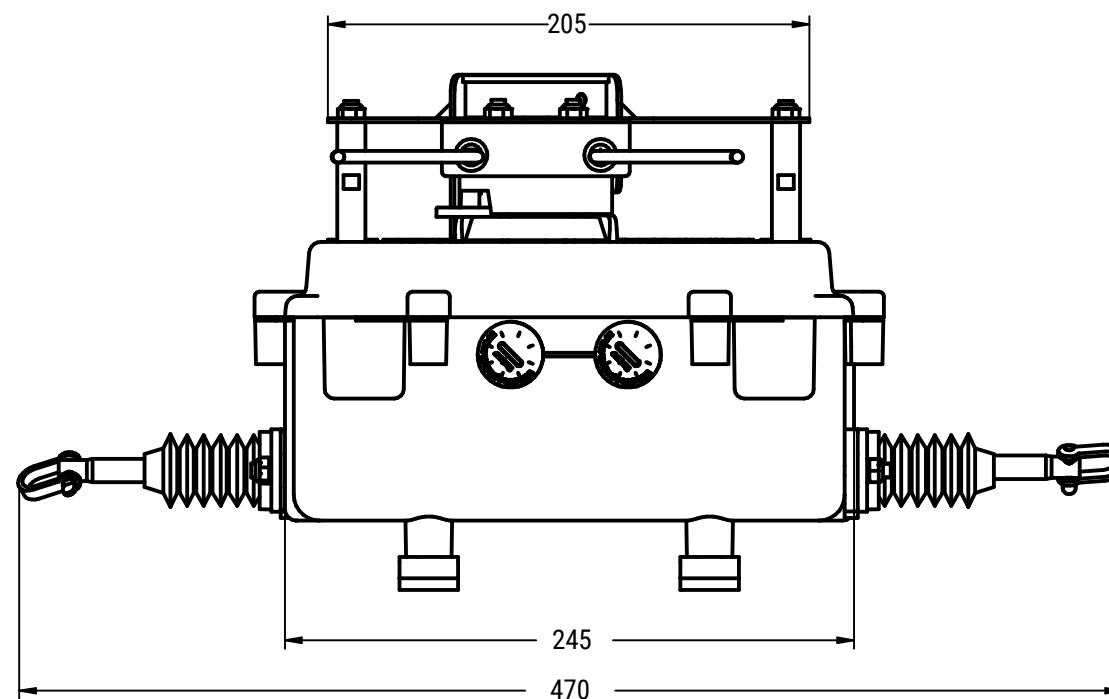
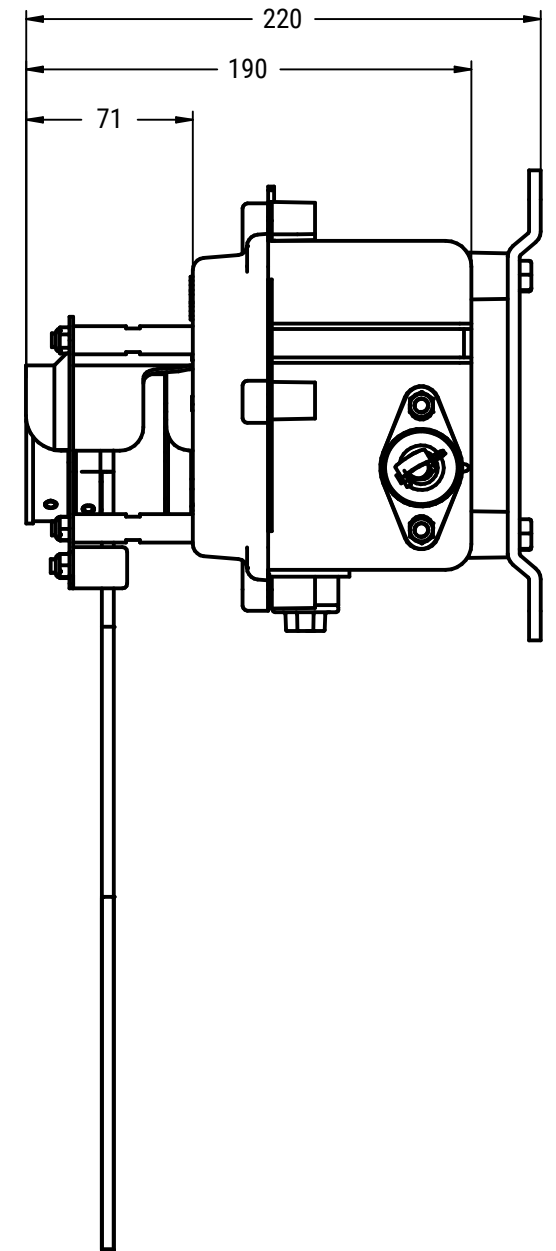
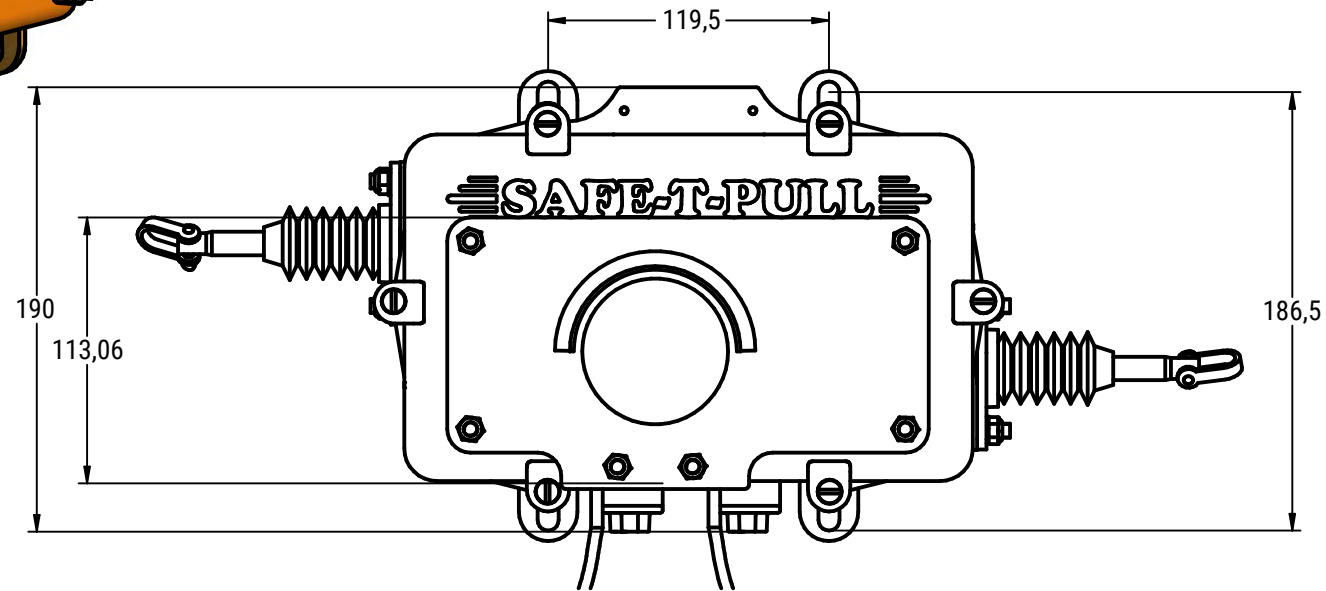

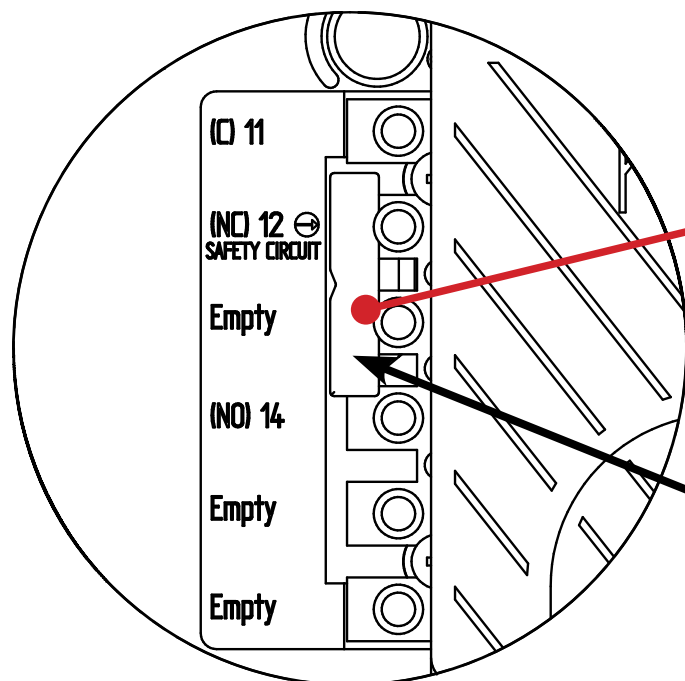
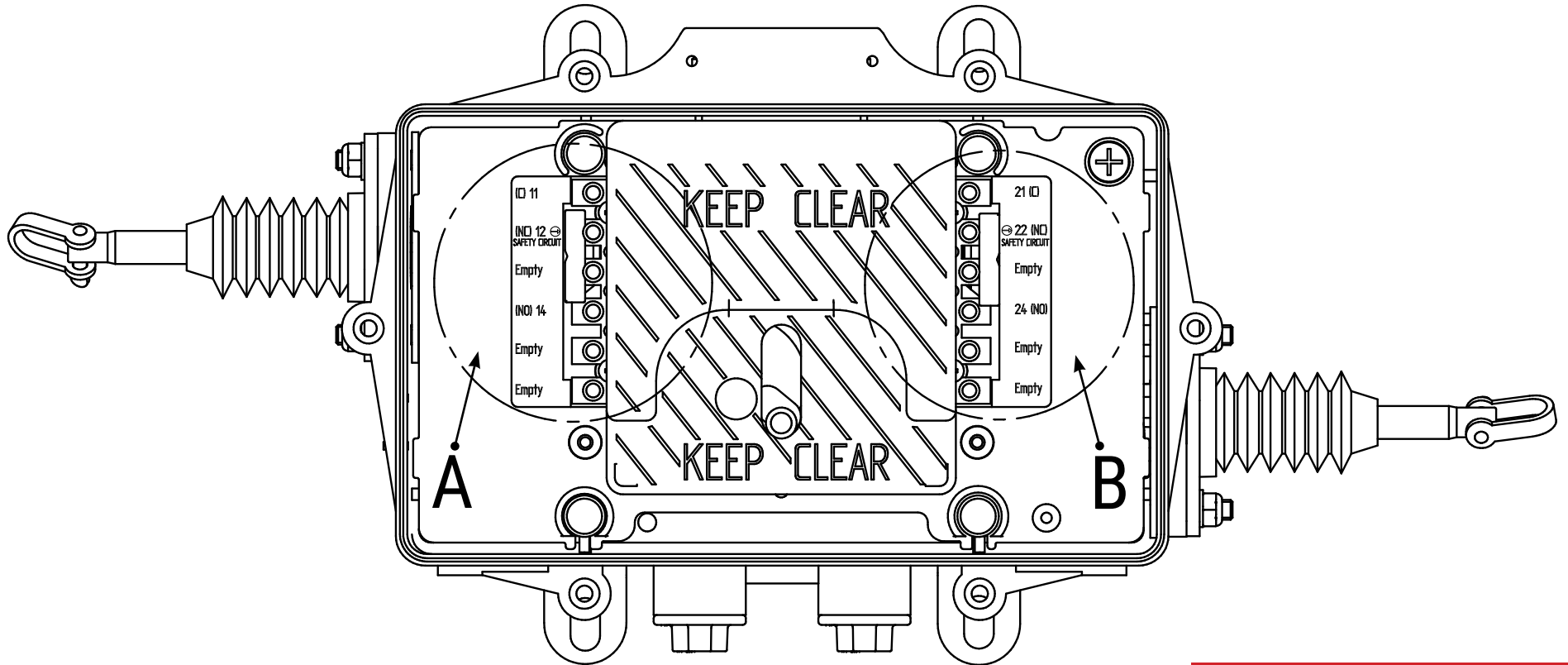

DETAIL A

SLIDE

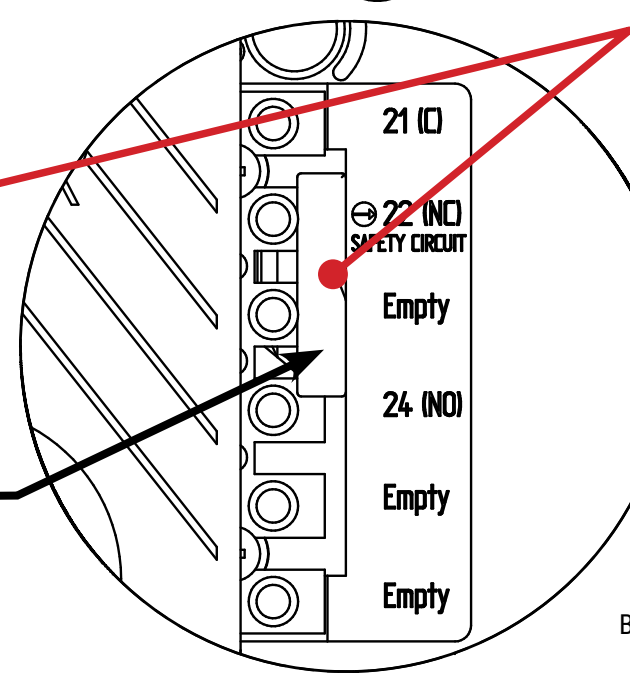

DETAIL B

**TERMINAL BLOCKER**  
**IMPORTANT NOTE:**  
 IEC 60947-5-1 2016  
 AS 60947-5-1 2015 Clause K.7.1.4.6.1  
 Form C or Form Za change over contact elements. Only one contact element (Make or Break) in each switch shall be used.  
 The blocker moves to block off the unused contact.



GENERAL CHARACTERISTICS		
<b>Safety Micro Switch with Direct Opening Action Specifications</b>		
IEC 60947-5-1 Annex K classification	Type 1 <input type="checkbox"/>	<input checked="" type="checkbox"/> Type 2 Direct Opening
Change-over contact element	<input checked="" type="checkbox"/> C	<input type="checkbox"/> Za <input type="checkbox"/> Zb
Contact material	Ag-Ni	
Utilization category	AC-15	DC-13
Operational voltage	260 V	60 V DC
Operational current	1,5 A	0.5 Amp DC
Frequency	50/60 Hz	--
Number of electrical cycles	6050 (6 min-1)	
Number of mechanical cycles	6050 (6 min-1)	
Conventional free air thermal current	10A	
Conventional enclosed thermal current	--	
IP Rating	67	
Service Temperature	-30° C No Icing	+80° C
<b>Specifications (short-circuit with standability)</b>		
Rated conditional short-circuit current	3 00 A	1 000 A
Short circuit protective device	Fuse 6 A gG (IEC 60269-2)	Fuse 6 A gR (IEC 60269-4)

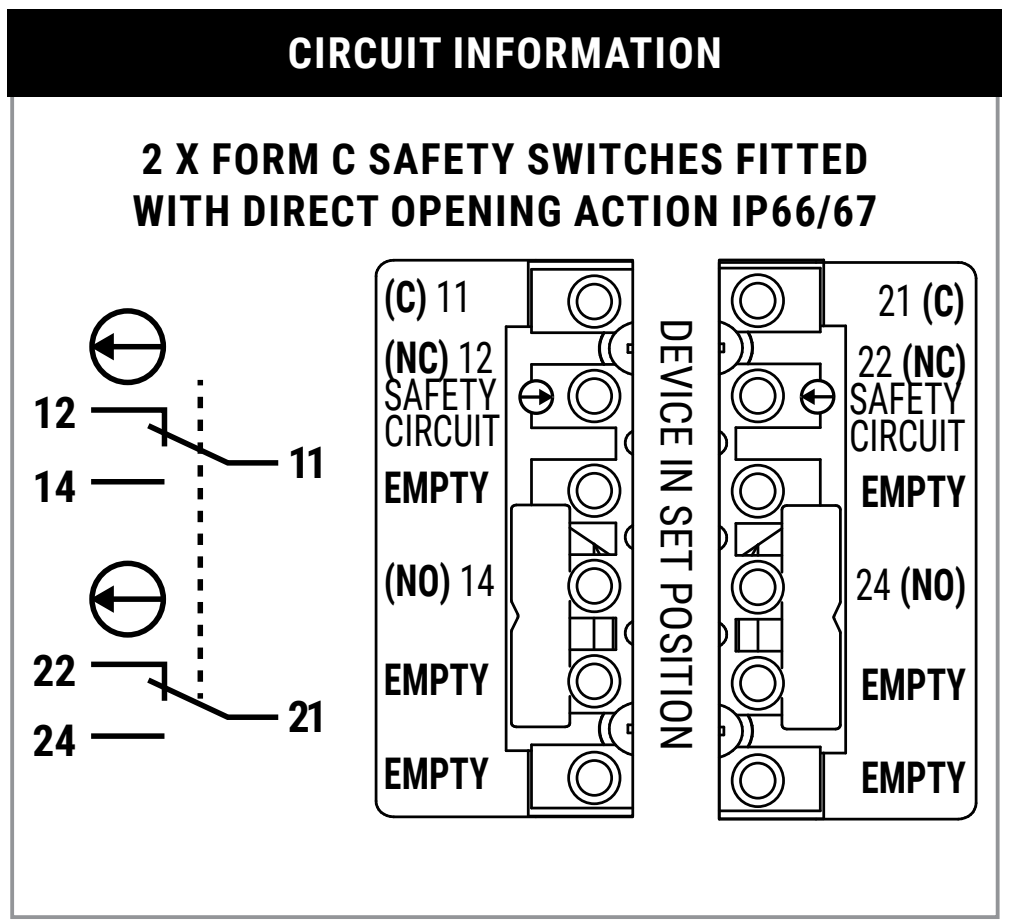

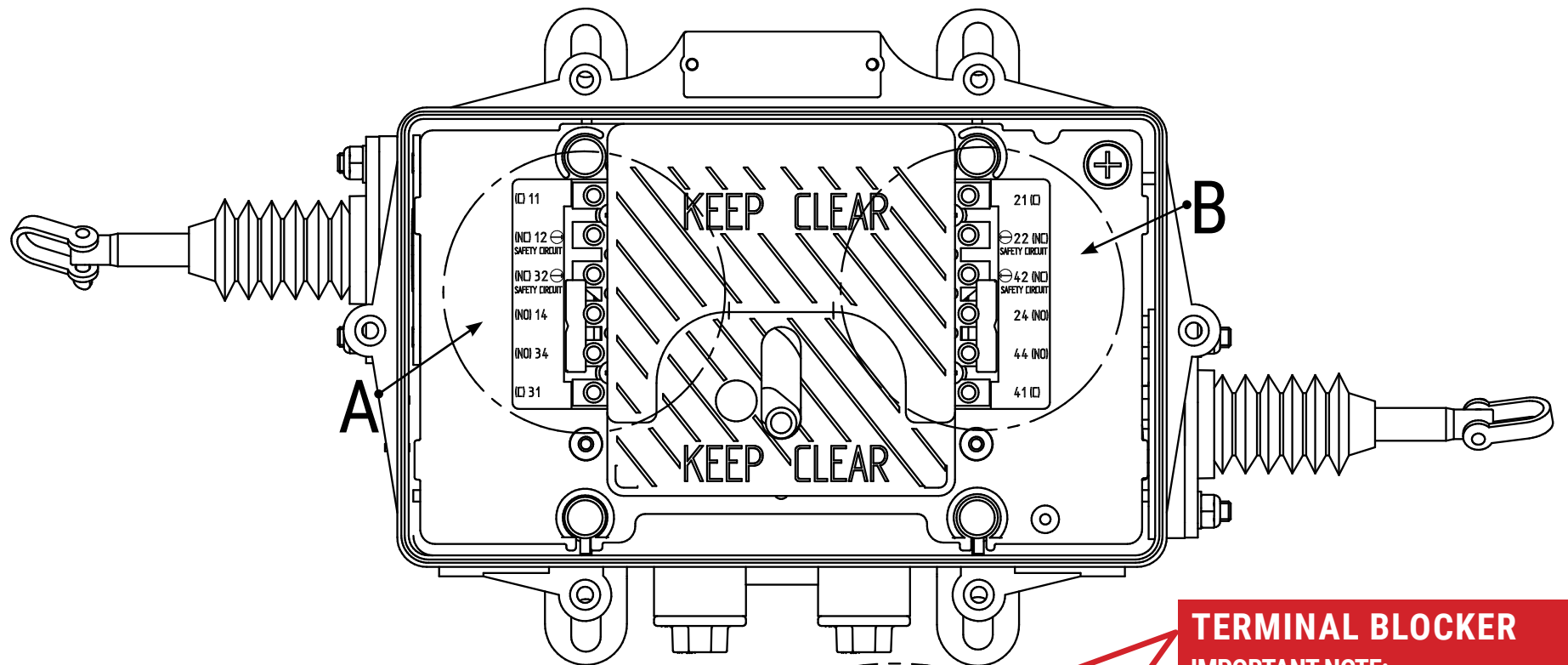

**TERMINAL BLOCKER**  
**IMPORTANT NOTE:**  
 IEC 60947-5-1 2016  
 AS 60947-5-1 2015 Clause K.7.1.4.6.1  
 Form C or Form Za change over contact elements. Only one contact element (Make or Break) in each switch shall be used.  
 The blocker moves to block off the unused contact.

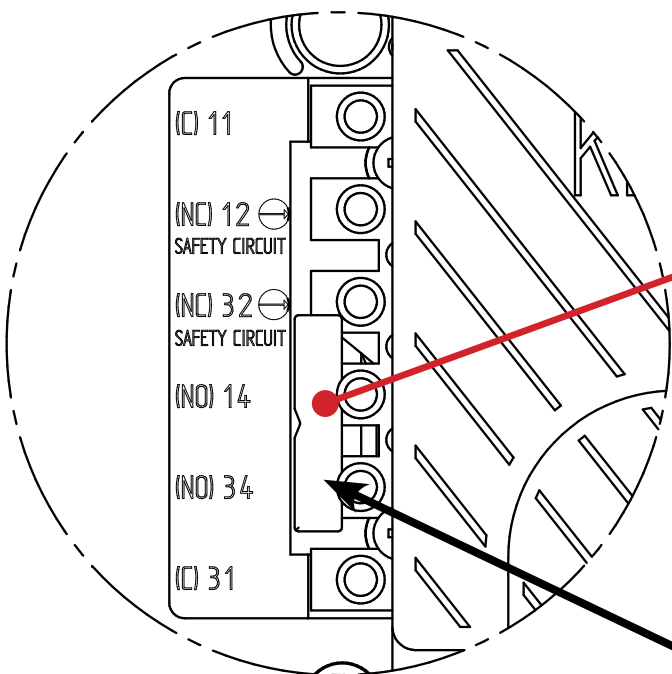

DETAIL A

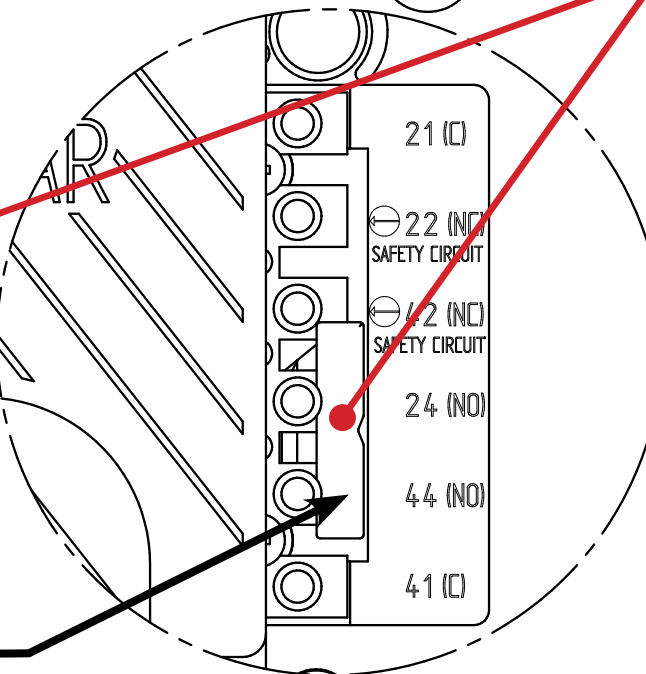

DETAIL B

AS SHOWN IN DETAIL A

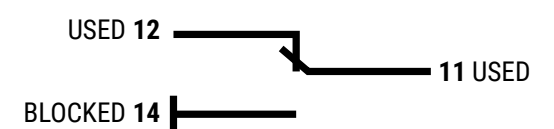

## GENERAL CHARACTERISTICS

### Safety Micro Switch with Direct Opening Action Specifications

IEC 60947-5-1 Annex K classification	<input type="checkbox"/> Type 1 <input checked="" type="checkbox"/> Type 2 Direct Opening
Change-over contact element	<input checked="" type="checkbox"/> C <input type="checkbox"/> Za <input type="checkbox"/> Zb
Contact material	Ag-Ni
Utilization category	AC-15 DC-13
Operational voltage	260 V 60 V DC
Operational current	1,5 A 0.5 Amp DC
Frequency	50/60 Hz --
Number of electrical cycles	6050 (6 min-1)
Number of mechanical cycles	6050 (6 min-1)
Conventional free air thermal current	10A
Conventional enclosed thermal current	--
IP Rating	67
Service Temperature	-30° C No Icing +80° C

### Specifications (short-circuit with standability)

Rated conditional short-circuit current	3 00 A	1 000 A
Short circuit protective device	Fuse 6 A gG (IEC 60269-2)	Fuse 6 A gR (IEC 60269-4)

## CIRCUIT INFORMATION

### 4 X FORM C SAFETY SWITCHES FITTED WITH DIRECT OPENING ACTION IP66/67

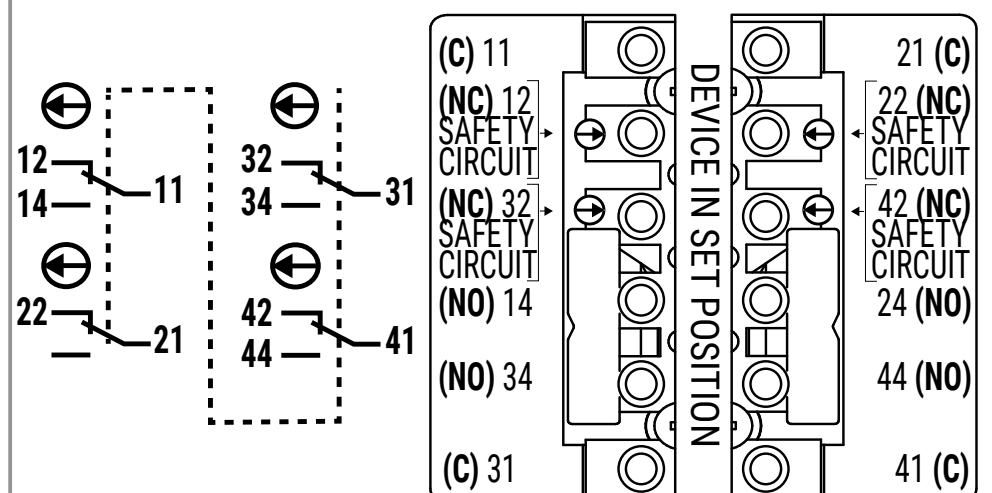



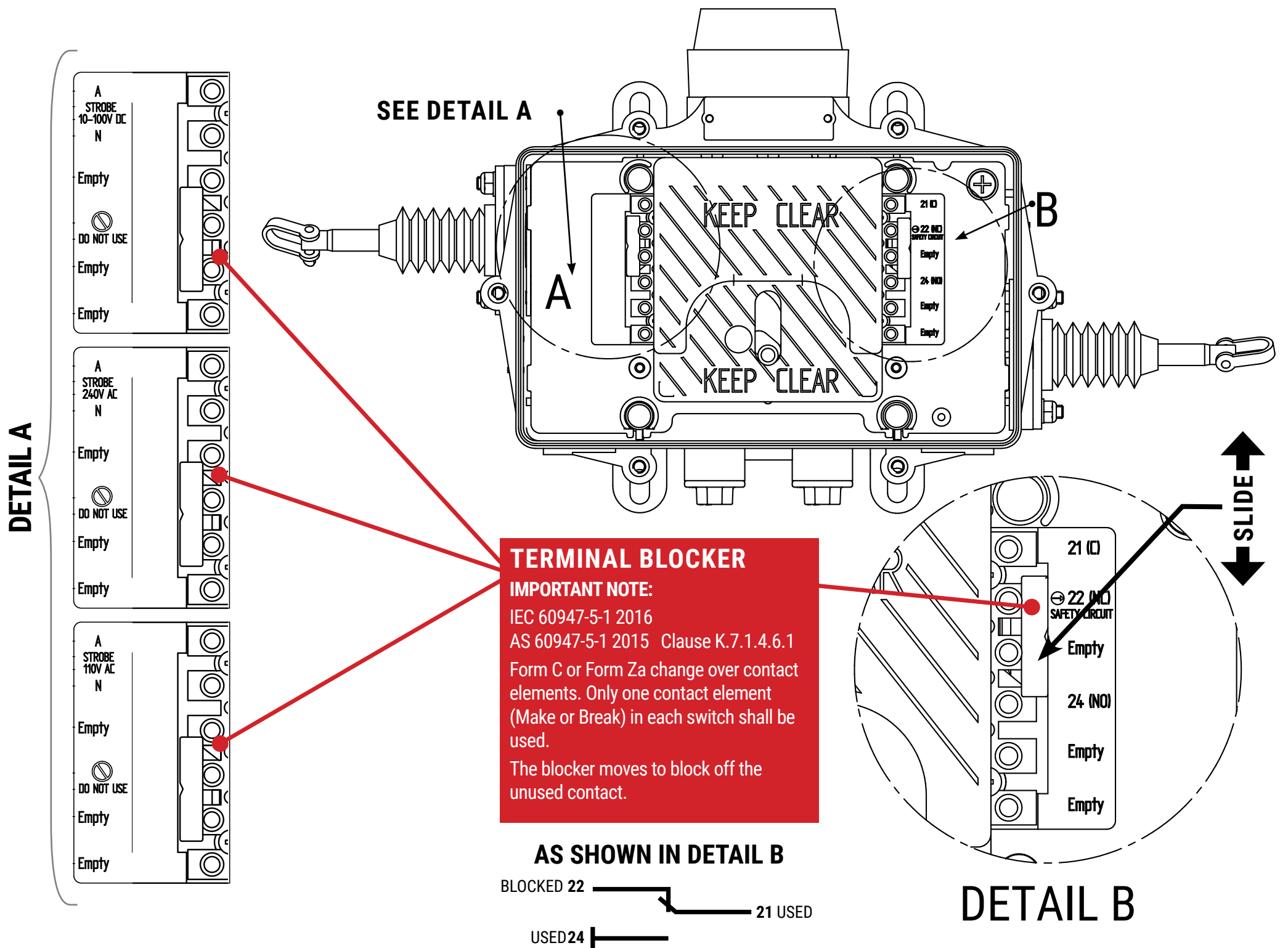

RED STROBE	
-S2	10-100V DC
-S3	110V AC
-S4	240V AC

AMBER STROBE	
-S6	10-100V DC
-S7	110V AC
-S8	240V AC

### GENERAL CHARACTERISTICS

Safety Micro Switch with Direct Opening Action Specifications		
IEC 60947-5-1 Annex K classification	<input type="checkbox"/> Type 1	<input checked="" type="checkbox"/> Type 2 Direct Opening
Change-over contact element	<input checked="" type="checkbox"/> C	<input type="checkbox"/> Za <input type="checkbox"/> Zb
Contact material	Ag-Ni	
Utilization category	AC-15	DC-13
Operational voltage	260 V	60 V DC
Operational current	1,5 A	0.5 Amp DC
Frequency	50/60 Hz	--
Number of electrical cycles	6050 (6 min-1)	
Number of mechanical cycles	6050 (6 min-1)	
Conventional free air thermal current	10A	
Conventional enclosed thermal current	--	
IP Rating	67	
Service Temperature	-30° C No Icing	+80° C

### CIRCUIT INFORMATION

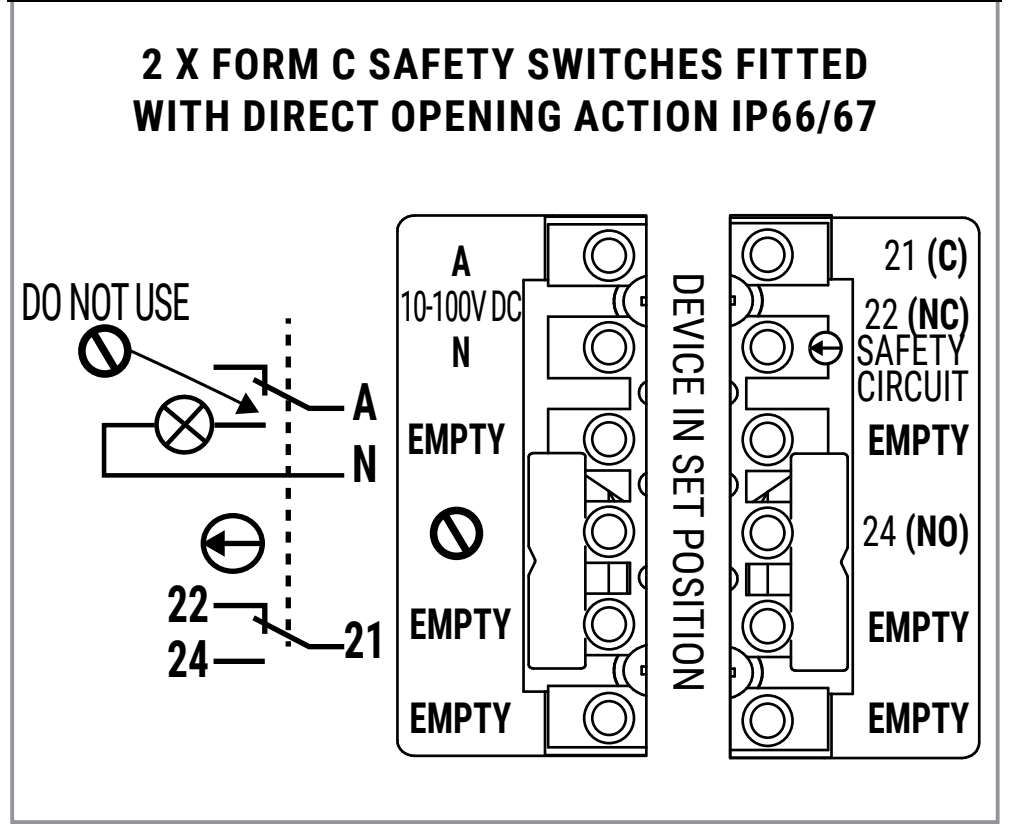

Specifications (short-circuit with standability)		
Rated conditional short-circuit current	3 00 A	1 000 A
Short circuit protective device	Fuse 6 A gG (IEC 60269-2)	Fuse 6 A gR (IEC 60269-4)

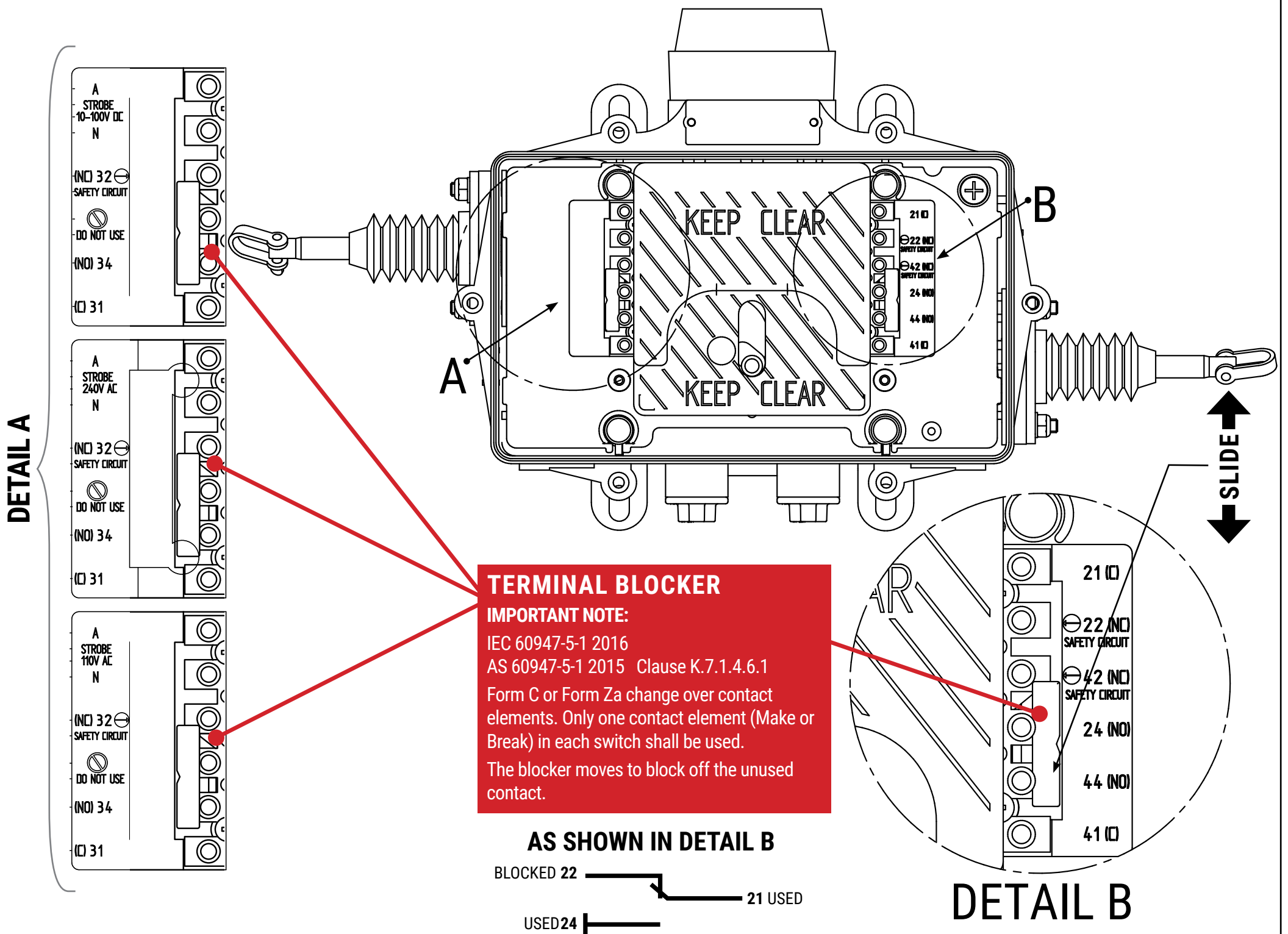

RED STROBE	
-S2	10-100V DC
-S3	110V AC
-S4	240V AC

AMBER STROBE	
-S6	10-100V DC
-S7	110V AC
-S8	240V AC

**GENERAL CHARACTERISTICS**

**Safety Micro Switch with Direct Opening Action Specifications**

IEC 60947-5-1 Annex K classification	<input type="checkbox"/> Type 1	<input checked="" type="checkbox"/> Type 2 Direct Opening
Change-over contact element	<input checked="" type="checkbox"/> C	<input type="checkbox"/> Za <input type="checkbox"/> Zb
Contact material	Ag-Ni	
Utilization category	AC-15	DC-13
Operational voltage	260 V	60 V DC
Operational current	1,5 A	0.5 Amp DC
Frequency	50/60 Hz	--
Number of electrical cycles	6050 (6 min-1)	
Number of mechanical cycles	6050 (6 min-1)	
Conventional free air thermal current	10A	
Conventional enclosed thermal current	--	
IP Rating	67	
Service Temperature	-30° C No Icing	+80° C

**CIRCUIT INFORMATION**

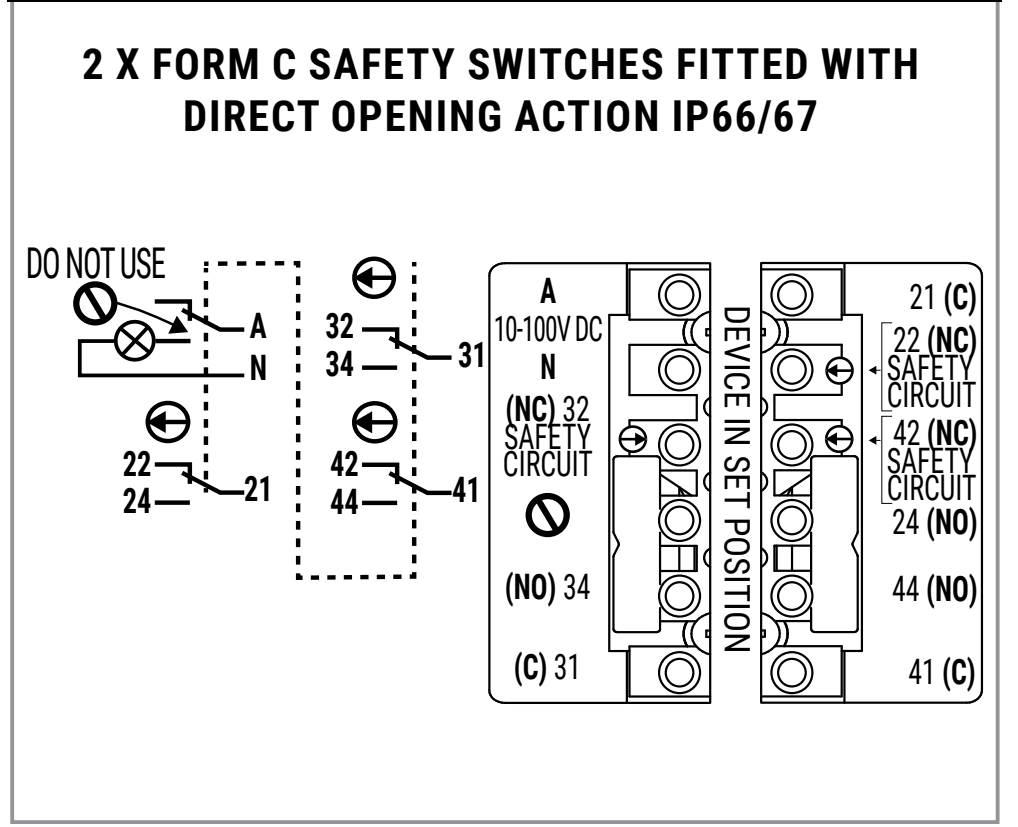

**Specifications (short-circuit with standability)**

Rated conditional short-circuit current	3 00 A	1 000 A
Short circuit protective device	Fuse 6 A gG (IEC 60269-2)	Fuse 6 A gR (IEC 60269-4)

## STANDARD

The SAFE-T-PULL complies with the relevant parts of these Standards

IEC 60947-5-1 Ed 3.1	Control circuit devices & switching elements
AS/NZS IEC 60947-5-1:2015	Control circuit devices & switching elements
IEC 60947-5-5 Ed 1.1	Control circuit devices & switching elements-Electrical emergency stop devices with mechanical latching function.
AS/NZS IEC 60947.5.5:2015	Control circuit devices & switching elements-Electrical emergency stop devices with mechanical latching function.
AS/NZS 4024.1-2014	Safety of Machinery.
AS/NZS 4024.3610:2015	Safety of Machinery, conveyors, general requirements.
AS/NZS 4024.3611:2015	Safety of Machinery, conveyors, belt conveyors for bulk materials handling.
SD Enclosures MDG 3608 7.2.2.1	Non-metallic materials for use in underground coal mines.

## Ce Conformity to:

2006/42/EC	Machinery Directive
2014/35/EU	Low Voltage Directive

## WORKSHOP TESTED

All devices are either hand or automation tested by trained technicians before leaving ELECTRIC CONTROL PRODUCTS and have a date and name label of manufacture inside them. The devices are then packed insuring full working order to our stringent test parameters.

A certification certificate is available on request for full compliance to the relevant standards.

## MODIFICATIONS OF DEVICE

Any modifications are ONLY to be made by ELECTRIC CONTROL PRODUCTS or one of their registered repairers. Any unauthorized modifications may not comply with the relevant standards and may diminish the integrity and workings of the device and the warranty will become void.

ELECTRIC CONTROL PRODUCTS and their registered repairers or distributors will not be responsible for any damage caused to the altered device or any item in, on, related or near the device, nor any injury incurred, nor actions resulting from the unauthorized alterations.

## RETURNS POLICY/RE-STOCKING

Please return any defective device to place of purchase for assessment. If they are deemed to be warranty repairs or not. Return warranty devices as per warranty clause. Restocking returns will only be accepted if received by ELECTRIC CONTROL PRODUCTS in their original condition and within thirty (30) days of delivery date stated on delivery documentation. A restocking fee applies (contact place of purchase for costs).

## WARRANTY

ELECTRIC CONTROL PRODUCTS of Perth Western Australia contact [info@safe-t-products.com.au](mailto:info@safe-t-products.com.au) warranty period is Twenty Four (24) months from date of purchase or longer if indicated by ELECTRIC CONTROL PRODUCTS. For warranty to be valid the goods must be received by ELECTRIC CONTROL PRODUCTS before the end of the Twenty Four (24) month period. ELECTRIC CONTROL PRODUCTS warrants that if any product is defective, it will, at its option, replace or repair the product. This warranty shall not apply to any defect which arises from improper use, failure to follow the products instruction, or any repair or modification made without the consent of ELECTRIC CONTROL PRODUCTS.

The customer must contact the Distributor of the product or ELECTRIC CONTROL PRODUCTS of Perth Western Australia via Email [info@safe-t-products.com.au](mailto:info@safe-t-products.com.au) before returning the faulty product. If returned they must be suitably packaged and, where relevant, returned in accordance with any particular instructions which ELECTRIC CONTROL PRODUCTS or one of its distributors may have notified the customer at the time of contact for warranty. Returned products must be accompanied by an advice note stating the nature of any defect being claimed. Any products or parts which are replaced by ELECTRIC CONTROL PRODUCTS or one of its distributors shall become the property of ELECTRIC CONTROL PRODUCTS. Title to replacement products shall pass to the customer on delivery, and the period of the warranty shall be calculated from the date of the defective product.

All warranty returns to ELECTRIC CONTROL PRODUCTS will be sent by the customer's freight at their cost. All benefits under this warranty are in addition to other rights and remedies of the consumer under a law in relation to the goods or services to which the warranty relates. Our goods come with guarantees that cannot be excluded under the Australian Consumer Law. You are entitled to a replacement or refund for a major failure and for compensation for any other reasonably foreseeable loss or damage. You are also entitled to have the goods repaired or replaced if the goods fail to be of acceptable quality and the failure does not amount to a major failure.



## PRODUCT LIFE EXPECTANCY

ELECTRIC CONTROL PRODUCTS estimate the product life expectancy to 10-15 years. Products should be changed after a maximum of 10 year life.

**NOTE:** Color fading is not necessarily product failure but a natural progression of any materials through it's life span. This is also dependent on the environment the product is installed in. A shorter or longer product life maybe experienced due to environmental situations. ELECTRIC CONTROL PRODUCTS can't give a written life expectancy on any of it's products due to the different situations the products are used.

## TECHNICAL SUPPORT

Technical advice will be given at any time by ELECTRIC CONTROL PRODUCTS or Distributor on any of the Electric Control Product range. Contact ELECTRIC CONTROL PRODUCTS or your local Distributor for this service.

## OBSOLETE PRODUCTS

Notification will be given to Distributors only for the products becoming obsolete and a time frame of when this will occur. Please contact Distributors for this information.

The obsolete product range will have spare parts for 12 months after becoming obsolete or until they run out, complete products may be available for a short time after it has become obsolete.

## LOCATION OF EMERGENCY STOPS

Emergency stops shall be located at each operator control station and other locations were emergency stop is required. Conveyors not greater than 2.5m in length and less than 2.7m above the floor, walkway or platform. A single stop control at a location which is easily accessible by the operator is all that is needed.

Conveyors greater than 2.5m in length and less than 2.7m above the floor, walkway or platform. They must have an emergency stop at the head, tail, drive and intervals not exceeding 30m along the length of the conveyor. Overland and long conveyors must have emergency stops every 30m so lanyards are advised to be used for best coverage for safety critical function.

Conveyors greater than 2.7m above the floor, walkway or platform. Locate emergency stops at positions were accessible and at intervals not exceeding 100m along the conveyor. Lanyards or Emergency Stop buttons may be used.

Emergency stop at positions adjacent to the conveyor where it can be started. Emergency stop at every permanent working station.

## 6 MONTHLY MAINTENANCE PROCEDURE

All devices require minimal maintenance but as in AS 4024.3610-2015 maintenance procedure shall be carried out.

Check that the devices are installed as per installation instructions.

Visual inspection of enclosure to ensure IP66/67 rating and correctly operating device. i.e. Damaged enclosure, bent pull rod, damaged dust boot etc.

Inspect all attachments are tight, free from obstructions and not worn and replace if necessary.

Inspect pull wire supports for wear, deterioration and build up of material, replace if necessary.

Inspect pull wire for wear or deterioration and replace if necessary.

Check that the pull rods are tensioned to the set position as per installation instructions, using either tape measure/ruler or **STP-SUG** gauge supplied with the device. (See page 1 for information)

**NOTE:** Pigtails and Eyebolts make very high static friction points and cause excessive wear and system disruption. ELECTRIC CONTROL PRODUCTS recommends the SAFE-T-GUIDE for critical safety function.

STP-P-\* STP-SD-\* STP-A-\* STP-SSB-\*

## SAFE-T-SPRING

The STP-E60 is the replacement of the STP-H60 compensation spring. The STP-E60 reduces spring friction and material build up; As a result, the emergency stop system is more reliable with less maintenance needed.



Compensation Spring is designed to be used with SAFE-T-PULL Lanyard Devices only.

### IMPORTANT MESSAGE

It's been found that the use of copper-based materials in mining situations can produce hazardous or explosive substances. This explosive material process is the reaction between copper or copper alloys being exposed to ammonium nitrate; a substance used extensively in mine explosives. This reaction between the two components causes a corrosion that is usually blue in colour. This blue corrosion may be the explosive tetraamine copper nitrate (TACN) which is formed when moisture, air, ammonia, copper, and electrical currents combine. When TACN dries it becomes an impact sensitive explosive. Electric Control Products used a tinned copper crimp on the STP-E60 compensation springs which has now been found that this could potentially become an explosive issue in the right conditions. Electric Control Products with this new information has now moved to the use of a stainless-steel crimp for the tether wire crimping in the STP-E60 spring.

### STP-E60 COMPENSATION SPRING REFERENCE

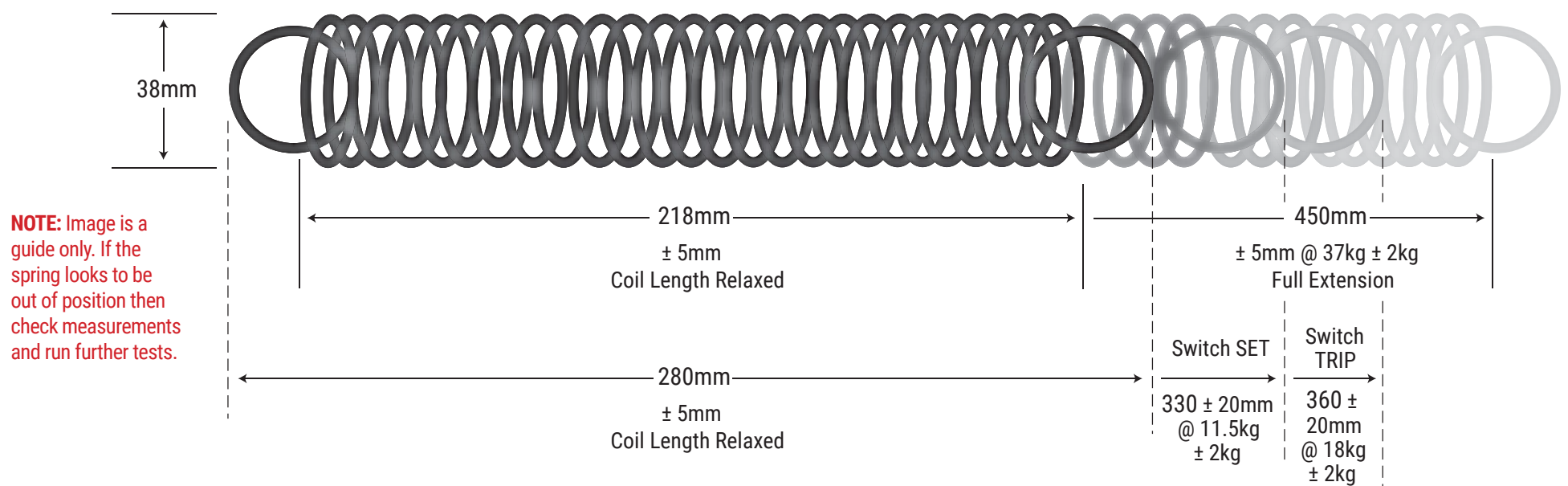

### FULL SAFETY MAINTENANCE PROCEDURE AT 12 MONTH RECOMMENDED INTERVALS, OR AS PER APPLIED RISK ASSESSMENT

#### TEST 1

Test that the SAFE-T-PULL Lanyard operates correctly.

This test is best done at the spring end of the pull wire system. This only needs to be done in each direction once. After each trip a device will need to be reset before the next test is to be conducted.

The system should pull and trip easily in each direction. No recorded pull measurements are needed for this test. This is just a pull wire movement test before test 2 is performed.

If the pulling of the wire is difficult or feels hard (should be less than, 10Kgf) then check the installation for worn pull wire, sharp bends, bent supports or items trapping the wire. If the problem is still present, contact the supplier of the product for advice.

**NOTE:** Keeping the pull wire straight or making sure to use long curved bends or STG-ERD-E \_ \_ \_ \_ \_ roller guides to bend around corners should keep the pull parameters in check.

#### TEST 1

#### AXIS PULL WIRE TEST

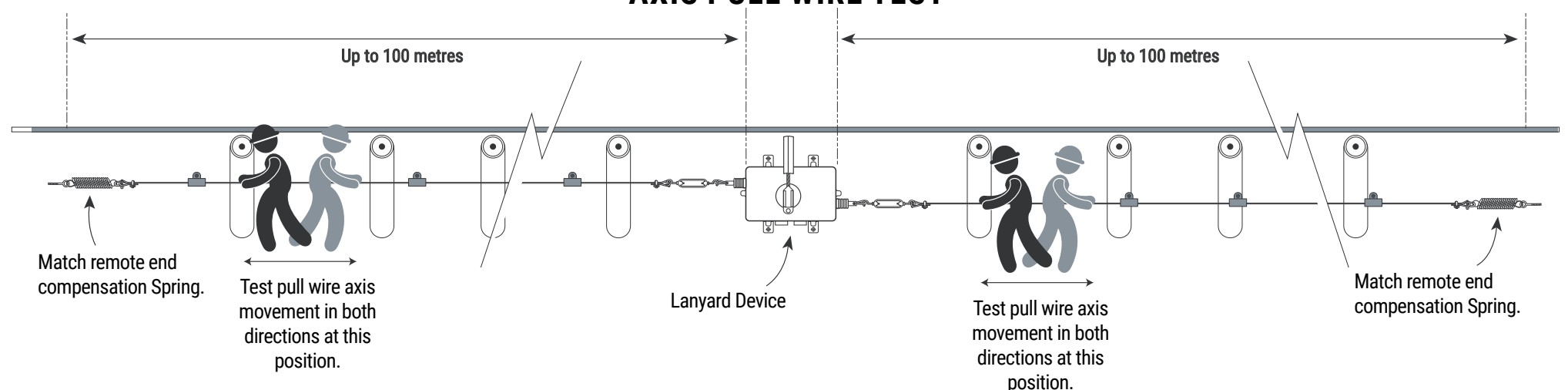

## TEST 2

Reset and attach calibrated or some other calibrated weight measurement device to the pull wire (See Figure 2), 90 degrees to the pull wire axis. A length measurement needs to be taken as well in this test. The test needs to be conducted 90 degrees to the pull wire's axis.

Pull the wire 90 degrees to the axis quickly using the calibrated or some other calibrated weight measurement device, measure the amount of force it takes to trip the device. There will be some over pull in this test so factor this into the measurement. Once the device trips check to see how far the pull wire needs to be pulled to activate a trip. An easy way to take this measurement when pulling the wire with the scales attached is start with your arm out stretched and pull quickly towards you stopping when your arm is bent 90 degrees next to your side, this measurement is about 400-450mm. NOTE: the pulling speed of the test will have an effect on the test results. As the wire is moving the whole length, faster the pull the lower the test result due to the reduction of the static friction between the rope and guides. In an emergency situation, the device will not be pulled slowly so the test should replicate this. AS 4024.3610 state the force used to activate a trip must not exceed 70N (7Kg) and the amount of pull should not exceed 300mm. NOTE: ELECTRIC CONTROL PRODUCTS risk assessment allows a pull distance can be up to 450mm and a maximum of 200 N as found in AS3947.5.5 Electrical emergency stop device with mechanical latching function mechanical requirements test, AS4024.1604 allows these recommendations. Attention must be paid to the surrounding environment and if this distance may be achieved safely. The Ergonomics HB-59 standard gives an average human arm reach distance of 500mm so 450mm pull distance would be acceptable. If the problem is still present contact the supplier of the product for advice.

If Eyebolts or Pigtails are being used, then this could be a factor as they increase the Pull Wire friction and can give high readings. Obstructions or sharp radius bends increase friction and give high readings, the use of the roller guide (STG-200-RG-SS) is recommended. Incorrect compensation spring or the device is seized or not working correctly could be the under laying problem.

The pull parameters are also governed by the positions of the rope guides and the position of the set point of the pull rod. If the rope guides are further apart than 3m then the Nm of force to pull the wire 90 degrees will decrease but the overall pull out length will increase and this is reversed if the guides are closer than 3m. Adjust the pull rod set point position out by 5-10mm (105-110mm) for shorter pull out tripping distance. This may increase nuisance tripping if not using STL-10-V pull wire.

## TEST 2

### 90 DEGREE PULL WIRE TEST

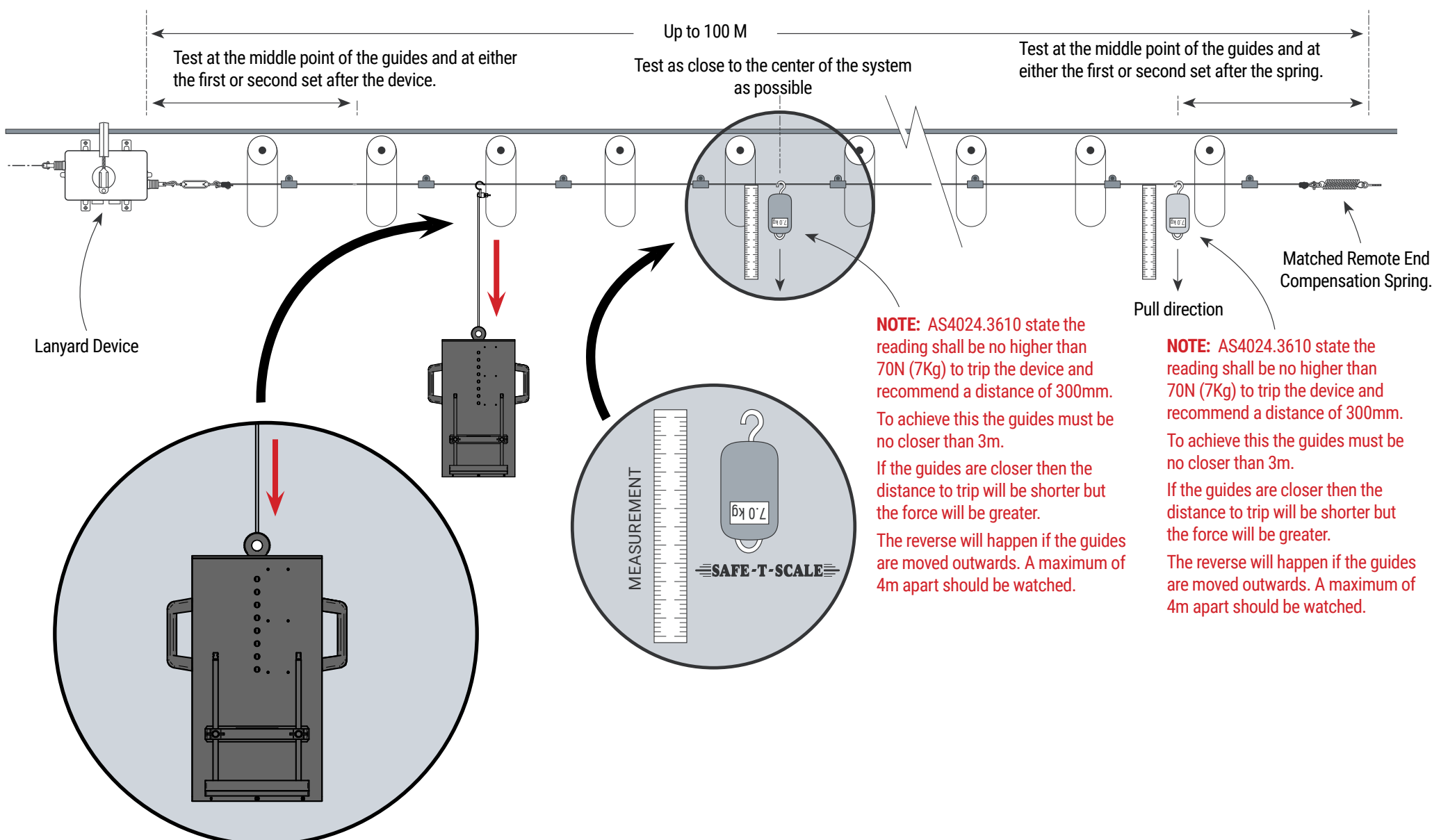

**NOTE:** After each activation tests are completed, visual check that the set position of the pull rods are as per installation instructions, if not readjust turnbuckle so the pull rods are at the set position before next test.



SYSTEM TESTING NOTE USING SAFE-T-TEST: TEST 1 "Axis Pull Wire Test" and Test 2 "90 Degree Pull Wire Test" are most efficiently run at the same time with two personnel walking the conveyor. A 200-metre pull wire system should take 15-20 minutes to test.

**NOTE:** After each activation tests are completed, visual check that the set position of the pull rods are as per installation instructions, if not readjust turnbuckle so the pull rods are at the set position before next test.

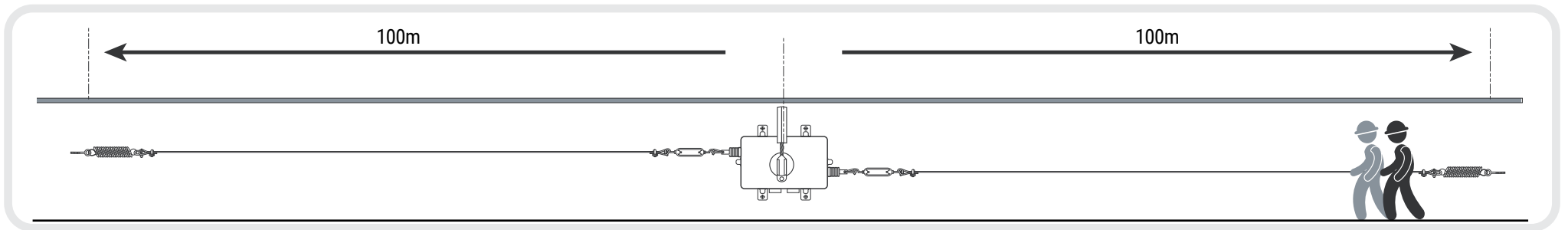

1. One person walks to the lanyard device and the other person stands at the spring and initiates the **Test 1**.

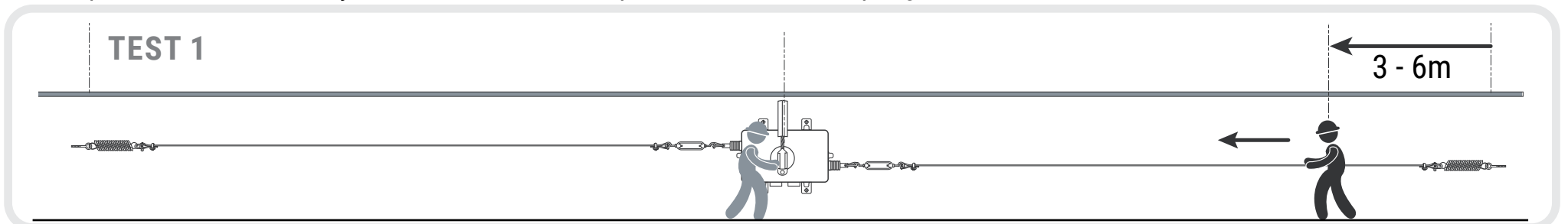

2. Once the device trips it is reset then another Test 1 is initiated in the same place but in the opposite direction.

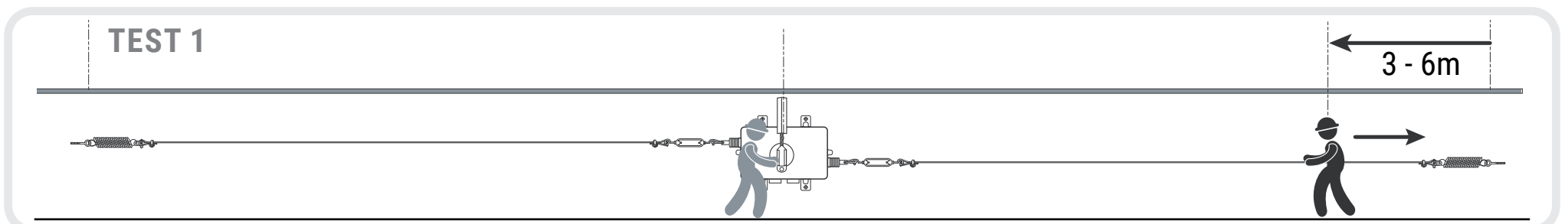

3. Then Test 2 is initiated at the spring end,

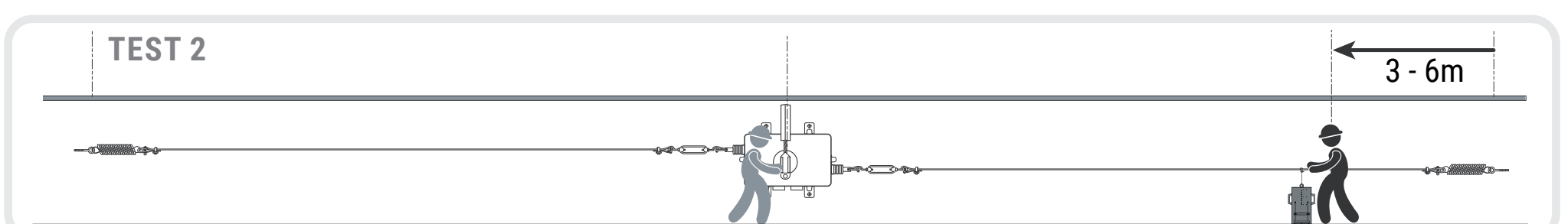

4. At the pull wire system centre between the spring and device,

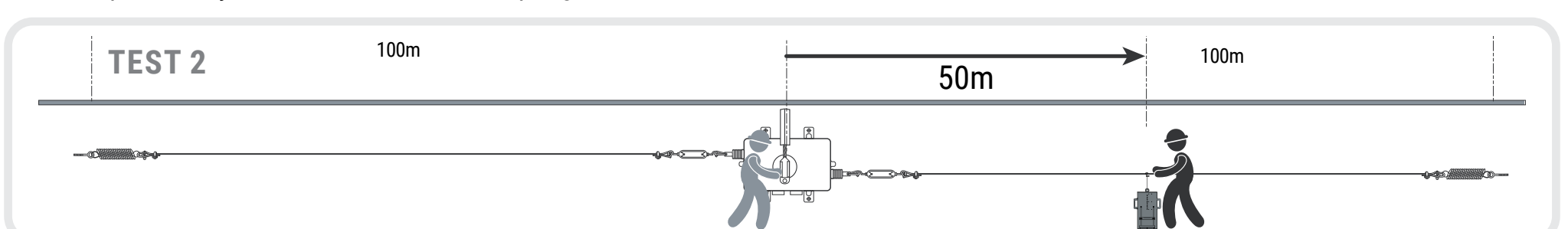

5. And the device end.

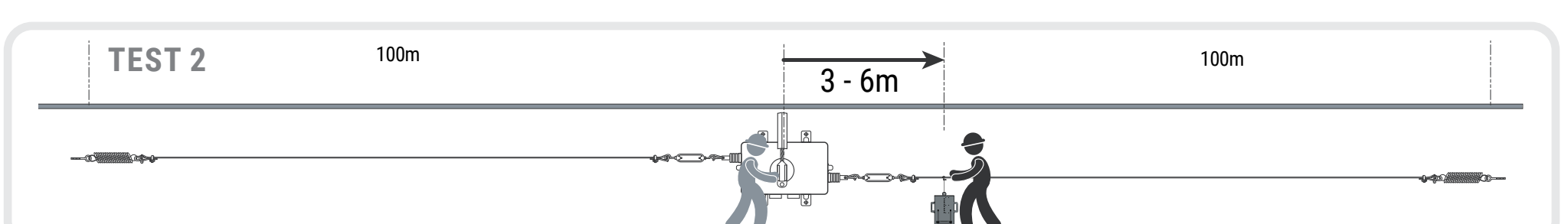

The SAFE-T-TEST as per the instructions and after each test the information is noted. Repeat the 5 step test on other side of device.

SYSTEM TESTING NOTE USING SAFE-T-SCALE: Test 1 "Axis Pull Wire Test" and Test 2 "90 Degree Pull Wire Test" are most efficiently run at the same time with two personnel walking the conveyor. A 200 metre pull wire system should take 15-20 minutes to test.

**NOTE:** After each activation tests are completed, visual check that the set position of the pull rods are as per installation instructions, if not readjust turnbuckle so the pull rods are at the set position before next test.

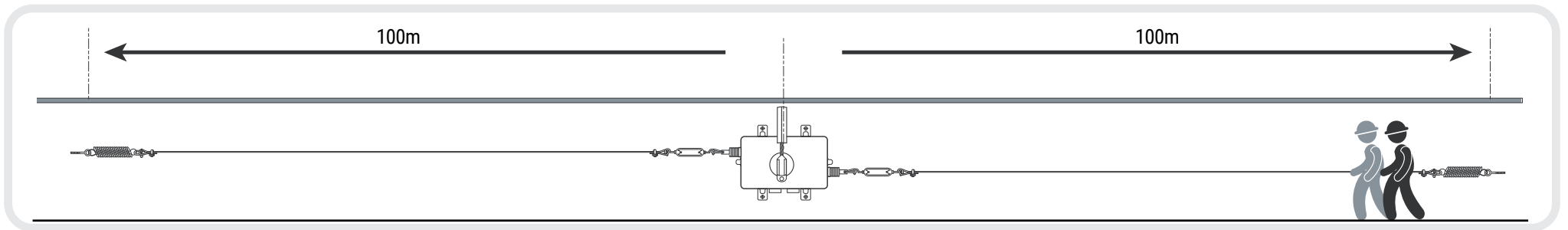

1. One person walks to the lanyard device and the other person stands at the spring and initiates the **Test 1**.

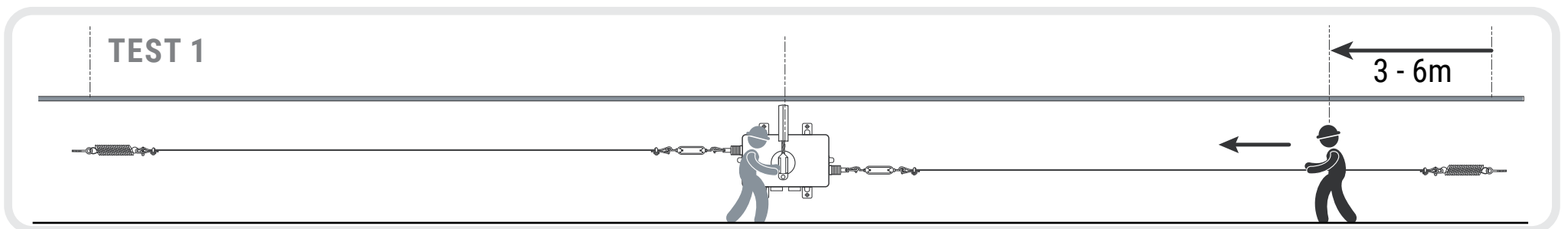

2. Once the device trips it is reset then another Test 1 is initiated in the same place but in the opposite direction.

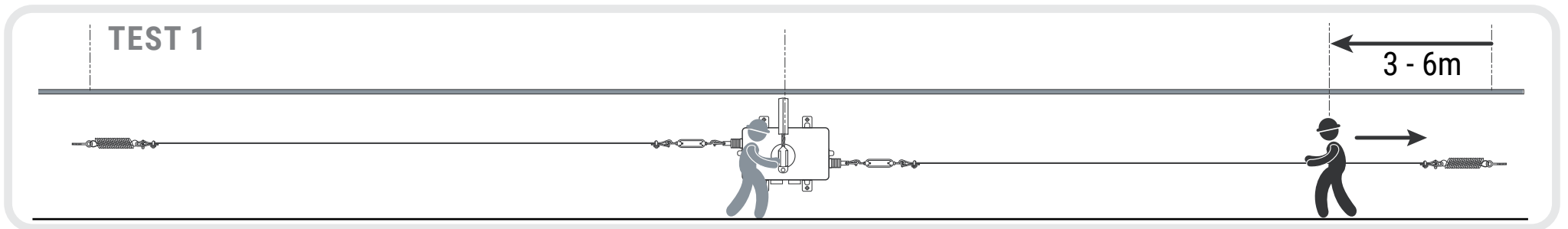

3. Then **Test 2** is initiated at the spring end,

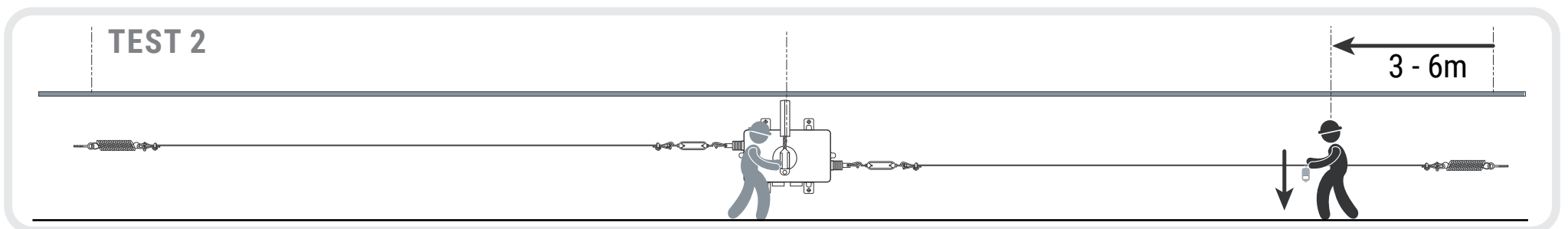

4. At the pull wire system centre between the spring and device,

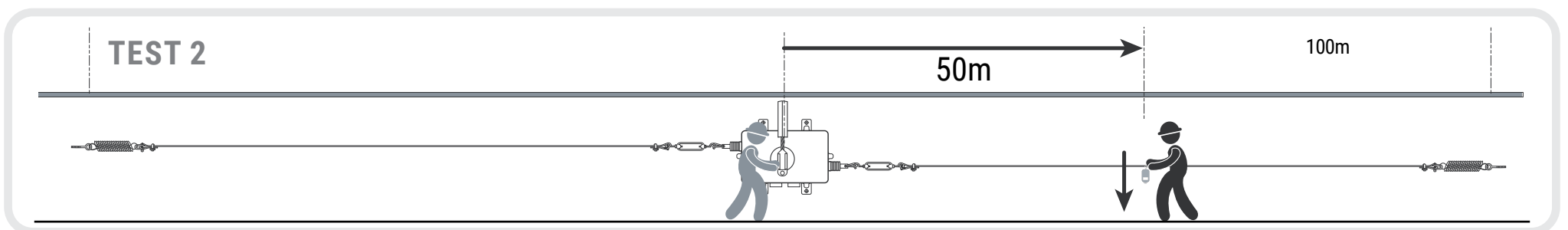

5. And the device end.

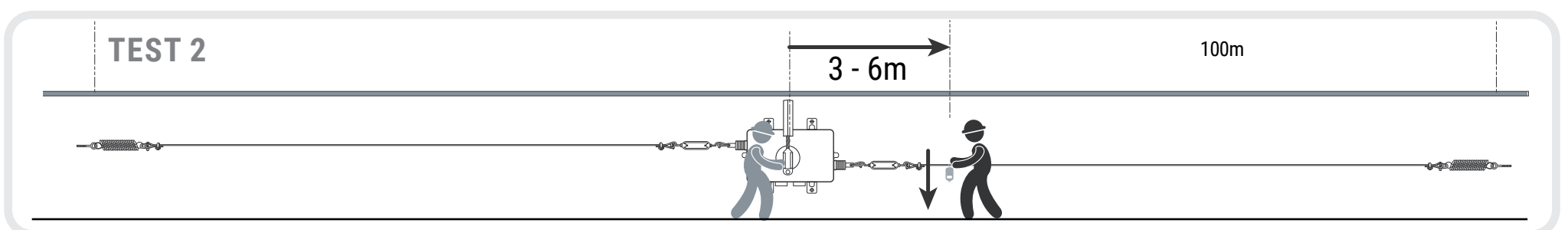

These test measurements are called out by the tester to the person at the device. The person at the device will reset the device and then document the measurements while the other person moves to the next test once one side is tested then this is repeated on the other side starting with test one and so forth.

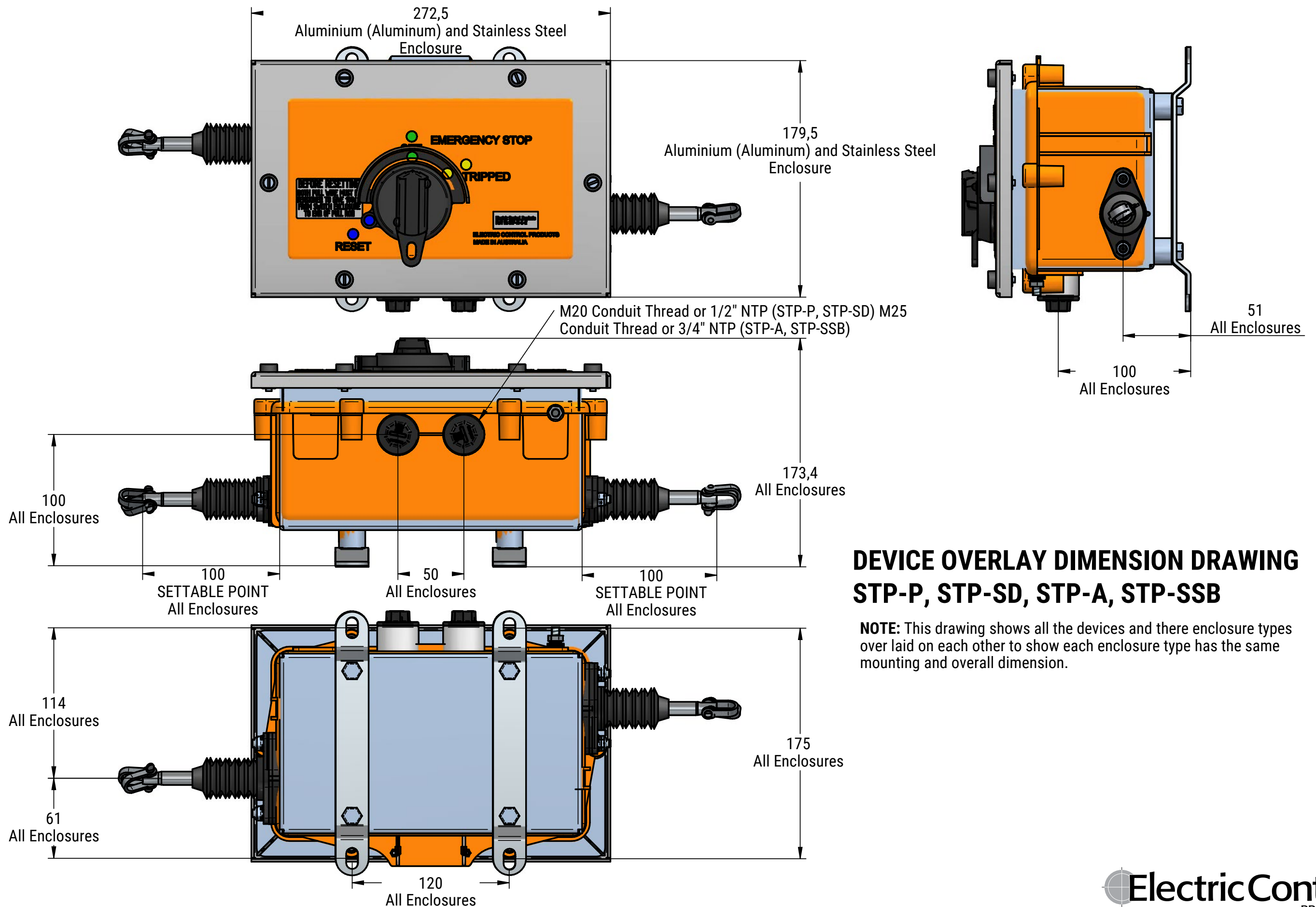

### DEVICE OVERLAY DIMENSION DRAWING STP-P, STP-SD, STP-A, STP-SSB

**NOTE:** This drawing shows all the devices and there enclosure types over laid on each other to show each enclosure type has the same mounting and overall dimension.



**NOTE:** The lid has a lid locking mechanism that stops the lid from being easily removed when in remote isolation.

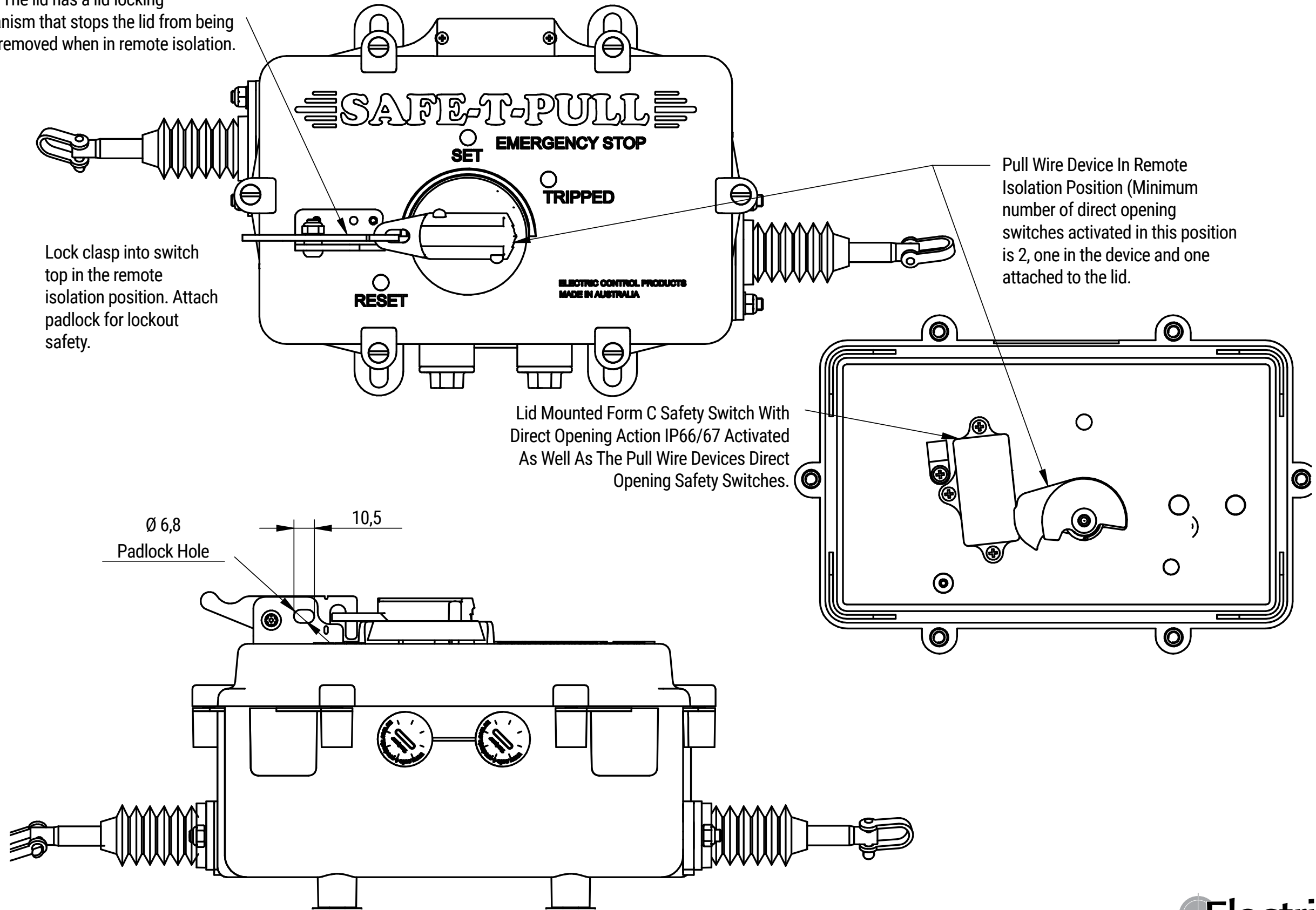

Lock clasp into switch top in the remote isolation position. Attach padlock for lockout safety.

Lid Mounted Form C Safety Switch With Direct Opening Action IP66/67 Activated As Well As The Pull Wire Devices Direct Opening Safety Switches.

Pull Wire Device In Remote Isolation Position (Minimum number of direct opening switches activated in this position is 2, one in the device and one attached to the lid.)

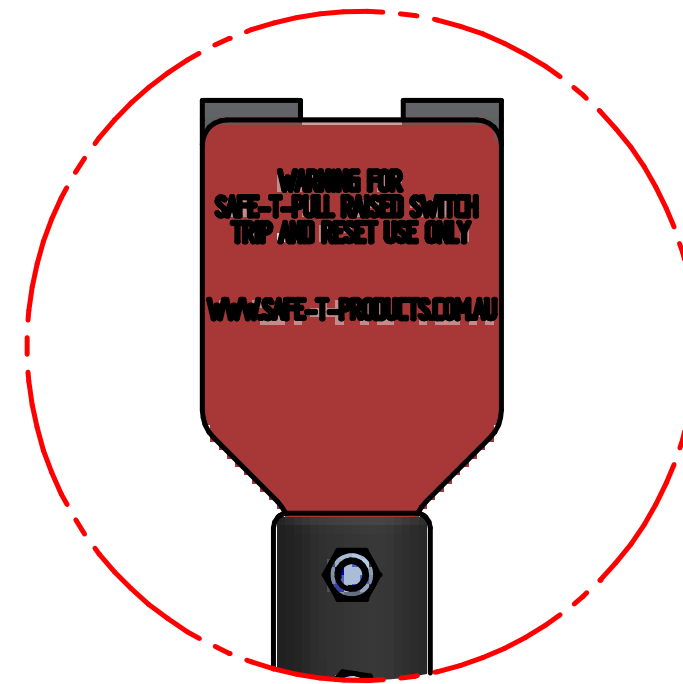
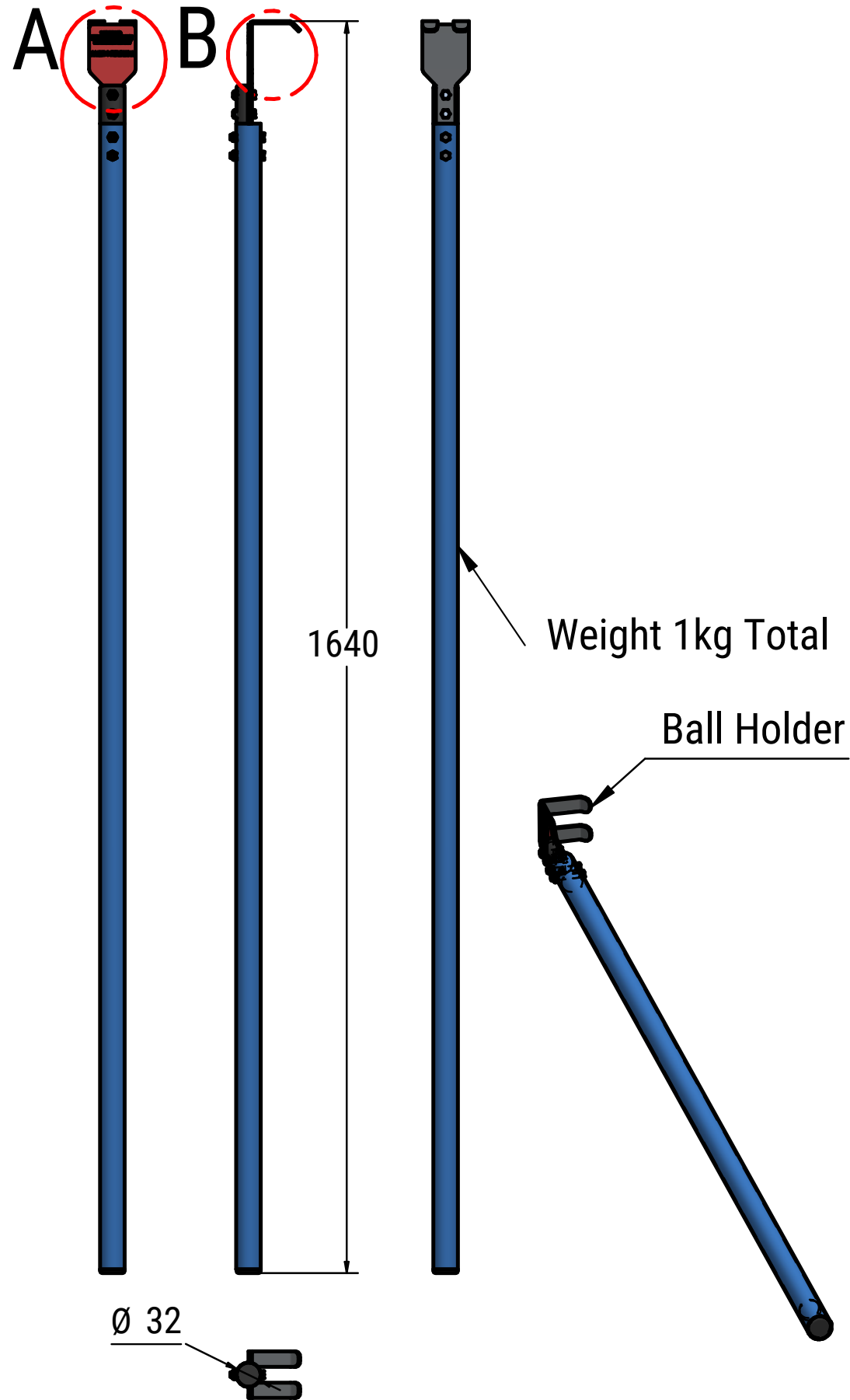

### DETAIL A

Pull Wire Testing Hook

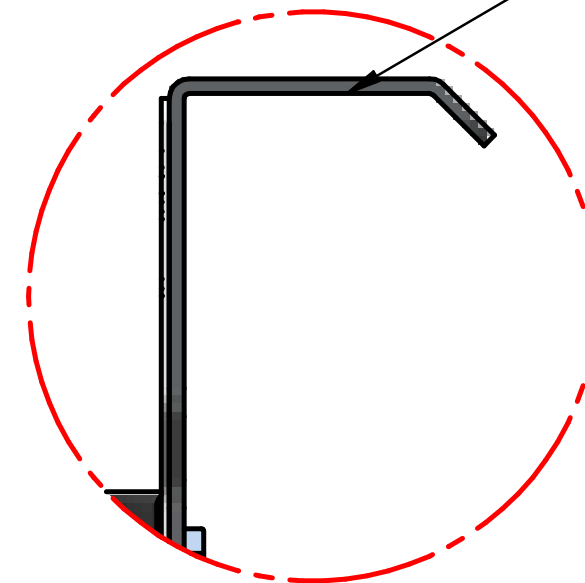

### DETAIL B

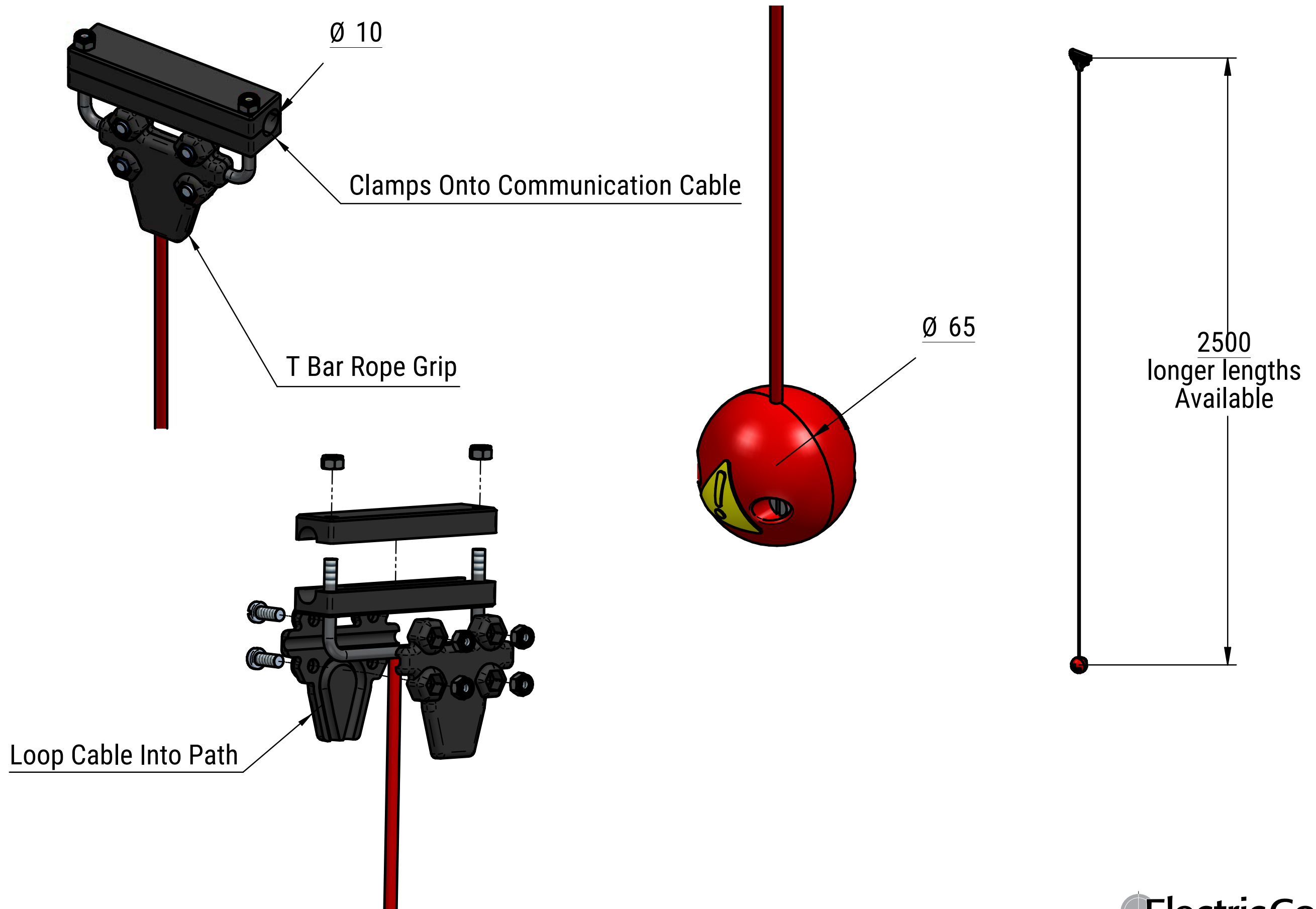



## REPLACEMENT LID ALLOCATION STICKERS SAFE-T-PULL STAINLESS STEEL

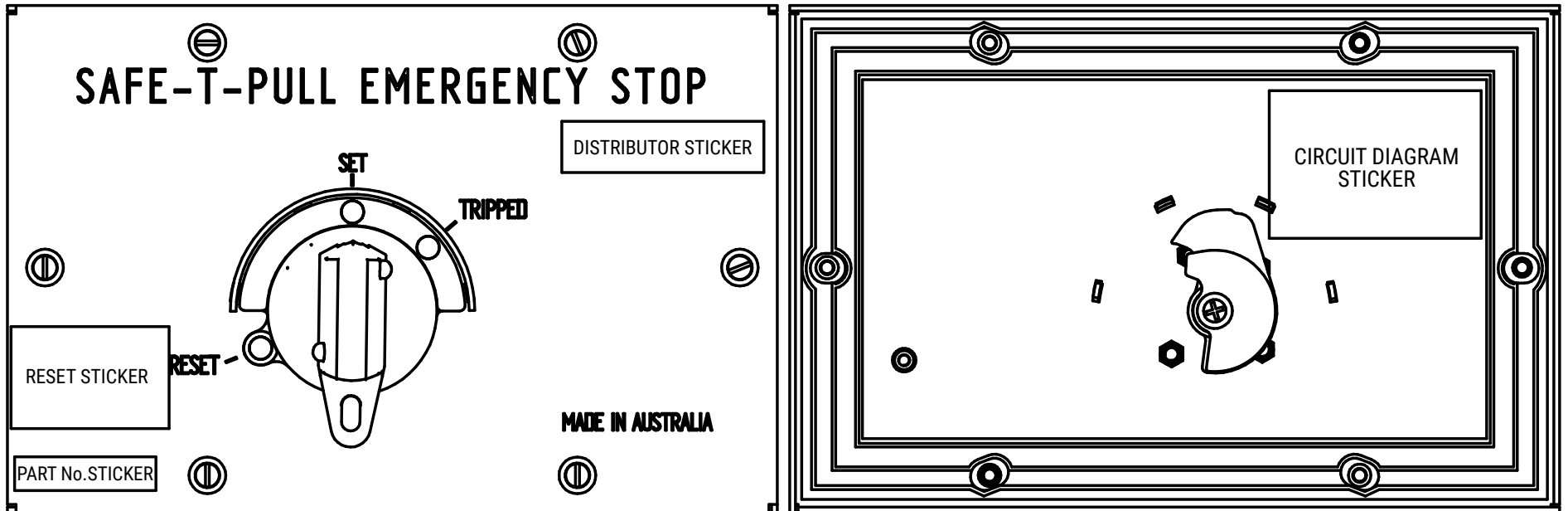

## REPLACEMENT LID ALLOCATION STICKERS SAFE-T-PULL PC/PBT PLASTIC

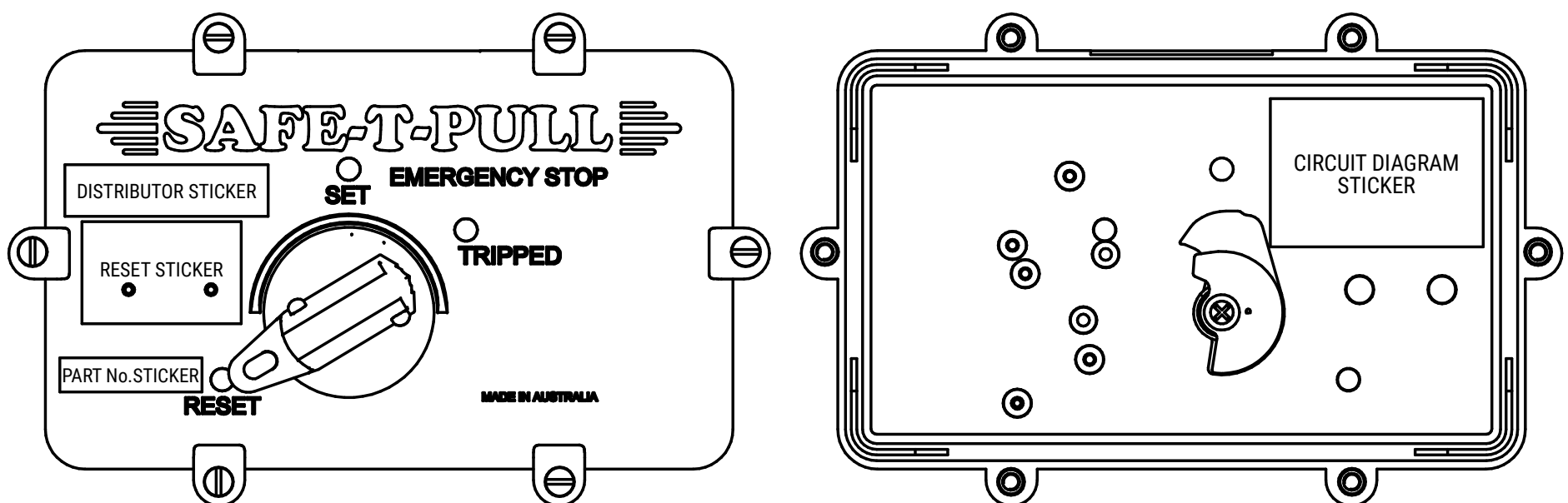

## REPLACEMENT LID ALLOCATION STICKERS SAFE-T-PULL STAINLESS STEEL REMOTE ISOLATION

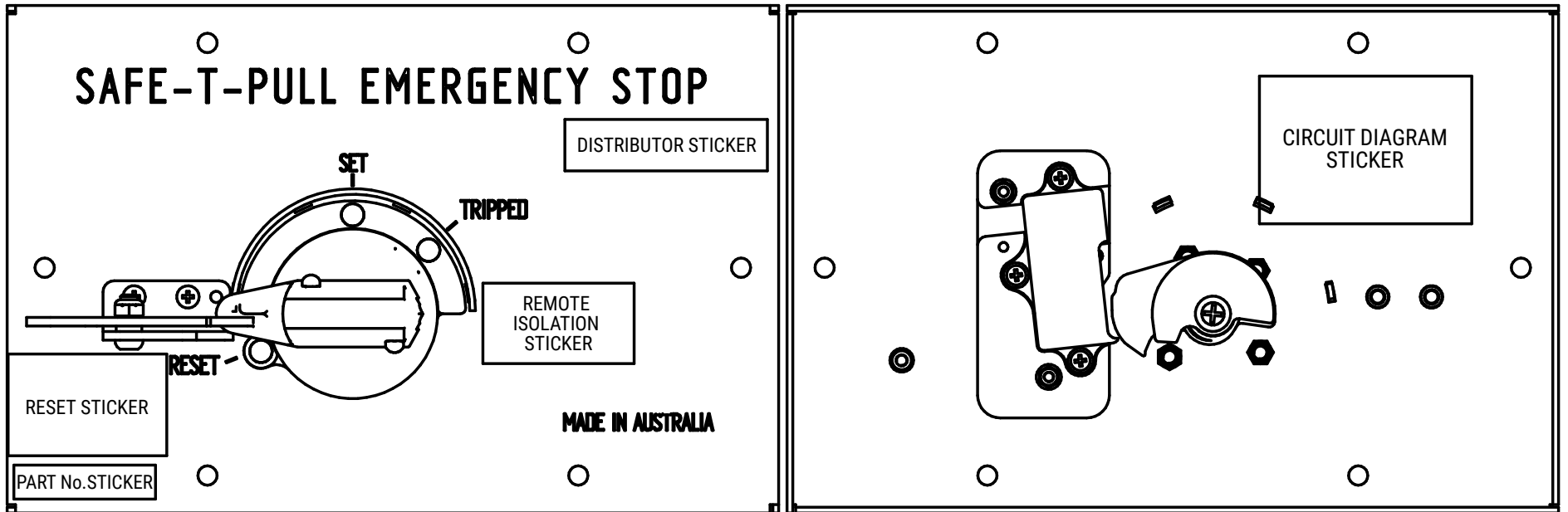

## REPLACEMENT LID ALLOCATION STICKERS SAFE-T-PULL PC/PBT PLASTIC REMOTE ISOLATION

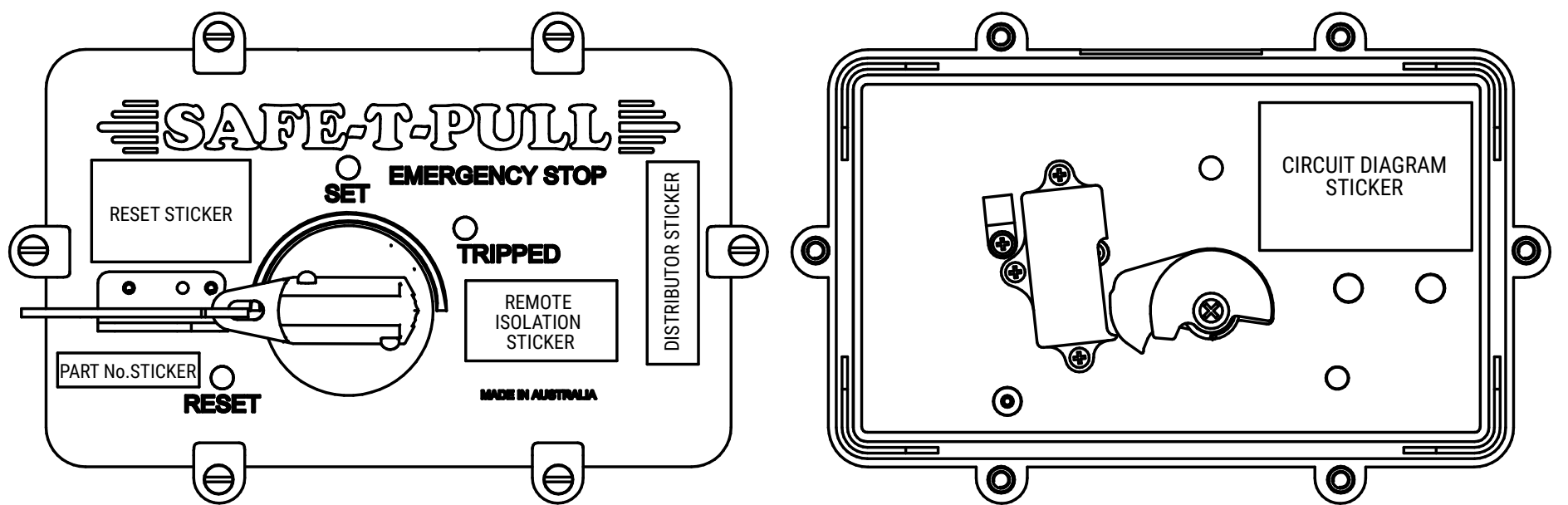

**Use in conjunction with Non Tension SAFE-T-PULL Installation Instructions**

CONVEYOR NUMBER:	
DEVICE 1 NUMBER:	DEVICE 2 NUMBER:
<b>Tick box for Yes (OK) or Cross box for No (Check)</b>	

**TEST 1: AXIS PULL WIRE TEST**

WIRE MOVES FREELY ON AXIS
AWAY FROM DEVICE 1
AWAY FROM DEVICE 2

**TEST 2: 90 DEGREE PULL WIRE TEST**

DEVICE 1 END	MIDDLE	DEVICE 2 END
Nm	Nm	Nm
mm	mm	mm

**GENERAL PULL WIRE SYSTEM INFORMATION**

PULL WIRE NEEDED REPLACING
PULL WIRE TERMINATION NEEDS FIXING
PULL WIRE WIRING TERMINATION NEEDS FIXING

**GUIDE POSITION TOO CLOSE**

DEVICE 1 END Under 600mm	GENERAL < 3m	DEVICE 1 END Under 600mm

**GUIDE POSITION TOO FAR**

DEVICE 1 END over 1m	GENERAL > 4m	DEVICE 2 END over 1m

**DEFLECTIONS OVER 16 DEGREES**

STAIRCASE	ROLLER GUIDE USED
STAIRCASE	ROLLER GUIDE USED

<b>PULL WIRE INSTALLATION</b>	<b>PULL WIRE BEHIND STRUCTURE</b>
-------------------------------	-----------------------------------

PULL WIRE WEAR	NOTES	Please Tick Boxes under heading		
		Behind Guard	Behind Objects	Not Accessible
HIGH FRICTION POINTS				
WIRE STUCK				
PIGTAILS				

**WIRE MOUNTED LOW < 900mm**

**WIRE MOUNTED HIGH > 1500mm**

**GUIDE REPLACE**

PIG TAIL - Conveyor Position No
EYE BOLT - Conveyor Position No
ROPE GUIDE - Conveyor Position No

**DEVICE REPLACEMENT**

DUST BOOT - Conveyor Position No
LID - Conveyor Position No
GENERAL - Conveyor Position No

**NOTES:**
