

Pendant Stations

cranes control circuits: **PL**



LIFTING EQUIPMENT



KIT Available See pg. 18

Available in UL/CSA req.

Characteristics:

- Bi-directional, mechanically interlocked
- IP 65 double insulation IEC/EN60529
- General and electrical data page 23
- Laser engraved symbols comply with EN60204-1, FEM 9.941
- Shock proof and heat resistant
- Available in UL/CSA requirements

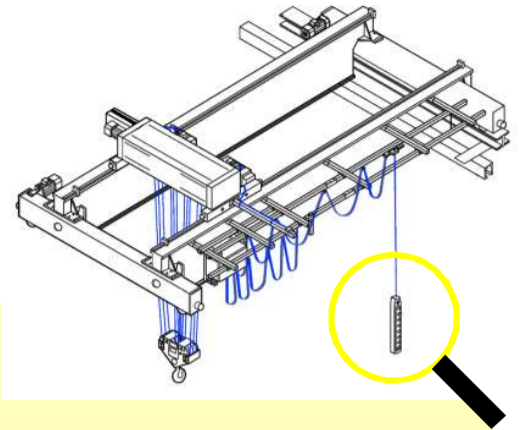

CODE	PL05	PL05D2	PL05D4	PL07	PL07D2	PL07D4	PL07D6	PL08	PL08D2	PL08D4	PL08D6	PL10	PL12
weight [gr.]	560	590	620	740	770	800	830	830	860	890	920	990	1.140
N° push button	5	5	5	7	7	7	7	8	8	8	8	10	12

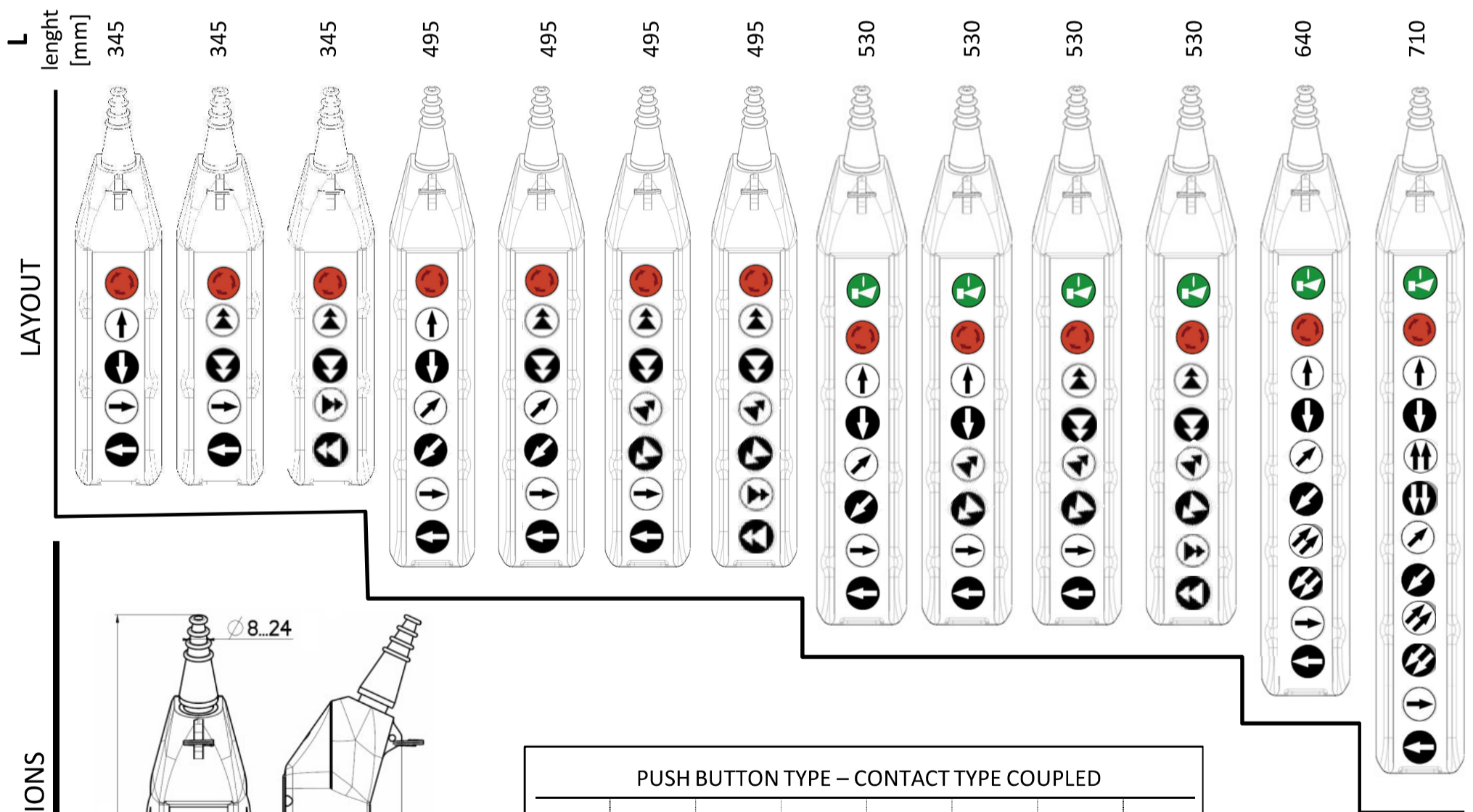

DIMENSIONS

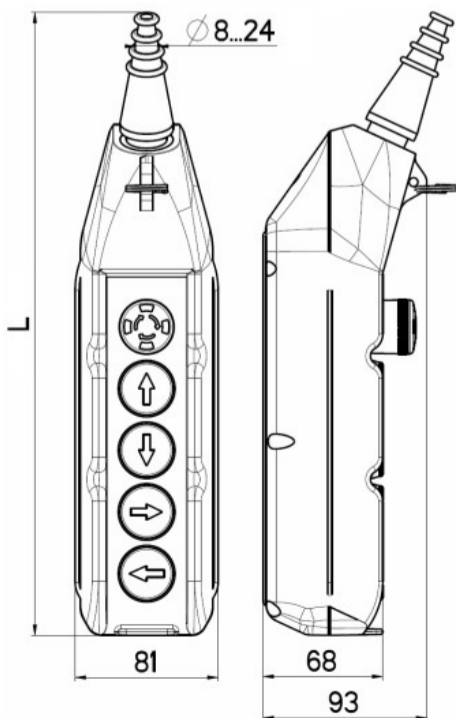

PUSH BUTTON TYPE – CONTACT TYPE COUPLED

(*) two speed contact block