

EMERGENCY STOP PULL WIRE DEVICE

UV STABLE, IMPACT MODIFIED, FLAME RETARDANT, PC/PBT ENCLOSURE.

Device features 3 Independent positive drive mechanisms and IP 66/67 Rated S.P.D.T Change-over Safety Micro Switches with Direct Opening Action for high safety performance, enclosed in an IP 66/67 flame retardant high impact enclosure.



» Yellow trip indication flag and plastic pull wire set up gauge supplied with all devices.

Tested to IP66/67
CE Conformity

The SAFE-T-PULL Pull Wire Device has been tested to the requirements of IEC 60947-5-5 and AS/NZS 4024 Series. Tripping occurs under the following conditions:-

- (a) One or both trip wires are removed or cut/broken
- (b) One or both trip wires are over-tensioned
- (c) One or both trip wires are activated
- (d) Manual trip via reset knob.

The device cannot be reset unless both trip wires are attached and correctly tensioned, Manual reset via the external reset knob is required after a trip has occurred.

FEATURES

- » Tamper Proof Switch Plate Mechanism.
- » Every Device is individually automation tested, electrically and mechanically with Test Certificates available.
- » Absolute simplicity in initial setup and adjustment. All Set Point adjustments are done from the outside of the enclosure.
- » UV stable, impact modified, flame retardant, PC/PBT enclosure.
- » Simple design ensures low maintenance.
- » Stainless steel internal compression type springs.
- » Electro polished 316 stainless steel pull rods and mounting feet.
- » Pull rods have spring loaded external dust protecting boots so the pull rod is always covered for extra seal protection and pull rods are not exposed to contaminants.
- » Double lip oil seals on pull rods and reset operator for secure dust and weather protection to IP 66/67.
- » Non-metallic pull rod bushings so no electrolysis issues between the safety mechanism (pull rod) and bushing. Increasing functional safety.
- » Independent positive drive pull rod cams, switch plate mechanism and lid drive cam for 3 fail safe trip mechanisms to ensure the device will trip and fail to safe.
- » Internal switch connections are fully shrouded for added safety during inspection.
- » IP 66/67 S.P.D.T Change-over Safety Micro Switches with Direct Opening Action (IEC 60947-5-1 Annex K) in contact element form C tested and passed too IEC 60947-5-1.
- » Cam design compensates for pull wire expansion/contraction up to 30mm either side of the set point. Eliminates nuisance tripping due to vibration.
- » Pull forces to actuate trip @ 60Nm (6Kg) 90° to pull wire axis and 90Nm (9Kg) along pull wire axis.
- » Cam position signal sensing before tripping.



FOR MORE INFORMATION
www.safe-t-products.com.au



VARIATIONS

- » Max 4 IP 66/67 S.P.D.T Change-over Safety Micro Switches with Direct Opening Action in contact element form C,
- » External signal flag (Note: Comes with device),
- » External light,
- » Single sided operation, right hand or left hand,
- » Two x M20 stainless steel armoured cable glands.

INSTALLATIONS

One centrally mounted device for every 200m of pull wire. Consult STP Safety, Installation, Design and Setting Instruction sheet for recommendations.

STANDARDS COMPLIANCE

AS/NZS 4024 Series AS/NZS IEC 60947.5.1:2015 AS/NZS IEC 60947.5.5:2015

IEC 60947.5.1:2016 RLV IEC 60947-5-5:1997+AMD1:2005+AMD2:2016 CSV

WHS (Mines) Regulations 2022 part 5.1 division 2, 191

REMOTE END

Matched stainless steel compensation springs for remote end attachment. P/N STP-E60.
To comply with safety critical functions AS/NZS 4024.3610 -2015 section 2.10.5 Emergency Stop. Ans ISO 13850 Emergency Stop Function - Principles For Design. A matched compensation spring must be fitted to the remote end of the Pull Wire to allow tripping in both directions.

DEVICE SETTINGS

Device setting is via a rope grip or turnbuckle from the outside of the Device. No internal access needed to adjust to set point.

ENCLOSURE SPECIFICATIONS

- » High Impact PC/PBT - Non Corrosive Material.
- » UV Stabilised. (See RTP 2099 Spec Sheet)
- » Flame retarded AS/NZS TM.UL94.V-0 (1.5mm)
- » Resists splash and spillage of most hydrocarbon solvents, mild acids and strong alkali. (See RTP 2099 Spec Sheet)

DIMENSIONS

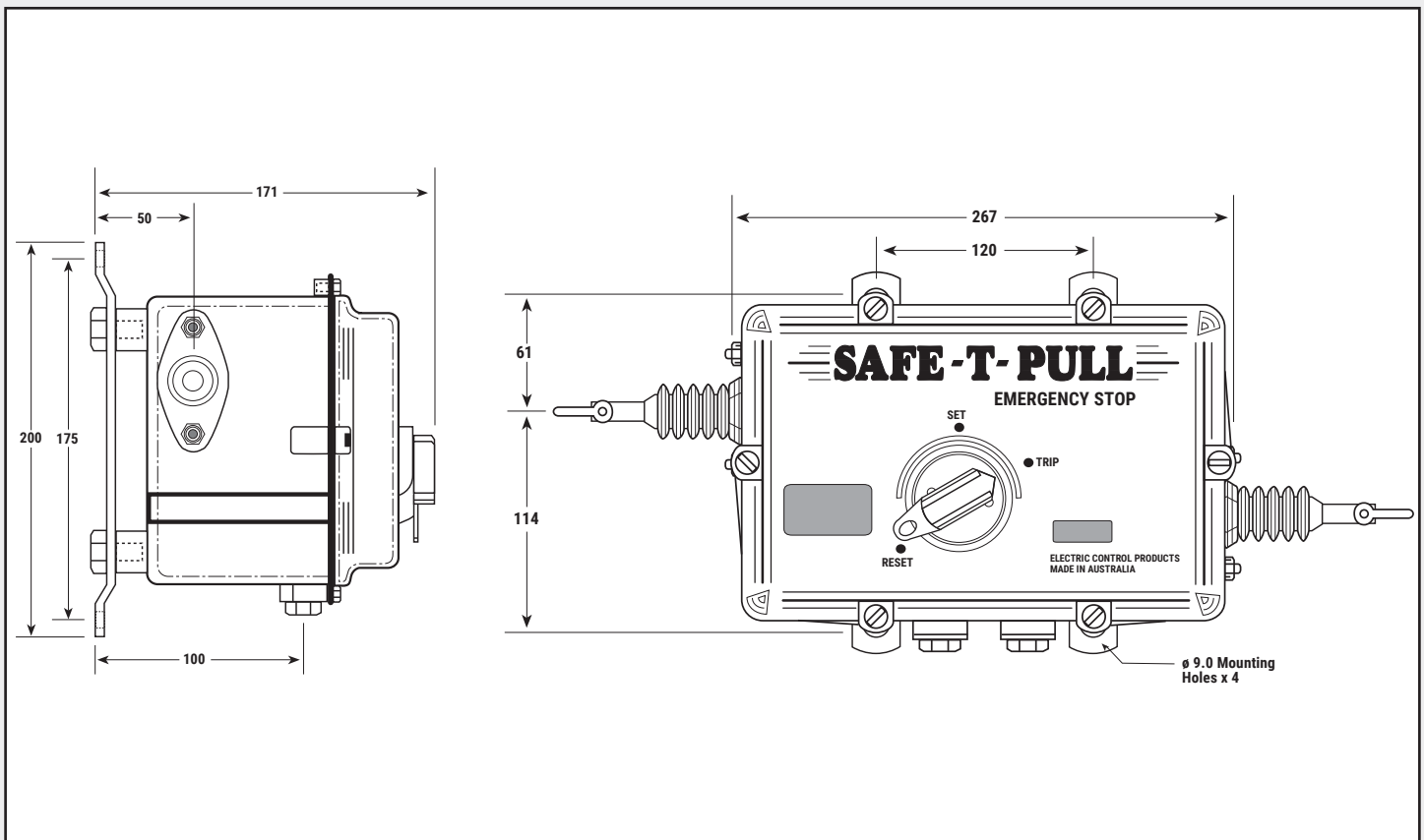

ELECTRICAL SPECIFICATIONS

IP 67 Safety Micro Switch with Direct Opening Action Specifications

IEC 60947-5-1 Annex K classification	<input type="checkbox"/> Type 1	<input checked="" type="checkbox"/> Type 2 Direct Opening
Change-over contact element	<input checked="" type="checkbox"/> C	<input type="checkbox"/> Za <input type="checkbox"/> Zb
Contact material	Ag-Ni	
Utilization category	AC-15	DC-13
Operational voltage	230 V	60 V
Operational current	1,5 A	0.5 A
Frequency	50/60 Hz	-----
Number of electrical cycles	6050 (6 min-1)	
Number of mechanical cycles	6050 (6 min-1)	
Conventional free air thermal current	10 A	
Conventional enclosed thermal current	-----	
Operating Temperature	-35° C No Icing	+80° C

Specifications (short-circuit with standability)

Rated conditional short-circuit current	3 00 A	1 000 A
Short circuit protective device	Fuse 6 A gG (IEC 60269-2)	Fuse 6 A gR (IEC 60269-4)

ORDERING DETAILS

STANDARD DEVICE	PART NUMBER
Standard Device with 316 Stainless Steel mounting feet and 2 IP 66/67 rated S.P.D.T Safety Micro Switches with Direct Opening Action	STP-P-2
Standard Device with 316 Stainless Steel mounting feet and 4 IP 66/67 rated S.P.D.T Safety Micro Switches with Direct Opening Action	STP-P-4
ADD TO ABOVE CAT NO. FOR VARIATIONS:	
External strobe light	-S#
S2 = Red Strobe for 10 – 100V DC 20 – 72V AC Current Use 130-37mA @ Flash Rate = 75fpm	-S2
S3 = Red Strobe for 90 -125V AC Current Use 30mA @ Flash Rate = 60fpm	-S3
S4 = Red Strobe for 207 – 253V AC Current Use 15mA @ Flash Rate = 60fpm	-S4
S6 = Amber Strobe for 10 – 100V DC 20 – 72V AC Current Use 130-37mA @ Flash Rate = 75fpm	-S6
S7 = Amber Strobe for 90 -125V AC Current Use 30mA @ Flash Rate = 60fpm	-S7
S8 = Amber Strobe for 207 – 253V AC Current Use 15mA @ Flash Rate = 60fpm	-S8
Left hand operation only	-LH
Right hand operation only	-RH
Two x M20 stainless steel armoured cable glands sockets	-ACGS
Matched SS Compensation Spring	STP-E60