

E FCT SERIES M12 CONNECTION & PRE-WIRED THERMOPLASTIC LIMIT SWITCHES



DESCRIPTION

Giovanzana offers two lines of pre-wired switches:

FCT series: prewired thermoplastic switches with IP67 protection rating with 2 mt cable. They are available in two different versions:

- with side cable entry;
 - with vertical cable entry.
- (The standard cable length is 2 mt but on request are available different sizes).

FCTM series: thermoplastic pre-wired switches with IP67 protection rating with M12 connector.

TECHNICAL DATA - HOUSING

Made of glass fibre reinforced technopolymer, self-extinguishing, shock-proof and with double insulation	
FCT Series	Version with integrated cable, standard lenght 2 mt. Other lenghts available on request.
FCTM Series	Version with integrated M12 connector.

GENERAL DATA

Utilization category	AC15 (Ue=240V, Ie=1.5A) - DC13 (Ue=240V, Ie=0,27A)
Insulation resistance	100MΩ min (DC 500V)
Conduit resistance	25mΩ max (Initial)
Operating temperature	Min -25°C (-18°F) / Max 70°C (+158°F)
Mechanical life expectancy	1x10 ⁷ cycles min
Electrically life expectancy	150.000 cycles min
Vibration resistance	IEC 68-2-6, 10-55Hz ± 1Hz, Excursion: 0.35mm, 1 octave/min

ELECTRICAL DATA

Rated thermal current (Ith)	Pre-cabled switches: 10A - Switches with M12, 4 pin connector: 4A
Rated insulation voltage (Ui)	500V AC
Rated impulse withstand voltage (Uimp)	4kV
Pollution degree	3
Protection against electric shock	Class II (Double insulation)

STANDARDS & APPROVALS

Standards	IEC/EN60947-5-1
Approvals	cULus, EAC and CCC for all applicable directives

QUALITY MARKS



PROTECTION CLASS

IP67 Designed to be used even in the most severe environmental situations, these devices pass the immersion test IP67 in conformity with EN 60529.

DATA TYPE APPROVED BY UL

Utilization categories:

FCT SERIES	A300	Q300	1 NC/1 NO Slow Action
			1 NC/1 NO Snap Action

In conformity with standards: UL508, CSA 22.2 No. 14 - 13.

Please contact our technical service for the list of approved products.



INTERNAL CABLE WIRING

Contact Types	X11	Z11
Contact Form	1NC/1NO Slow Action	1NC/1NO Snap Action
Electrical Schemes		

CONNECTOR PIN ASSIGNMENT

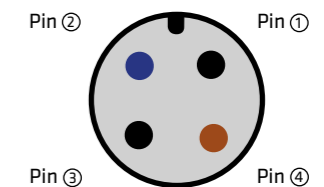

CONTACT No.	CABLE COLOR
Pin 1	Black
Pin 2	Blue
Pin 3	Black
Pin 4	Brown

PRODUCT SELECTION

FCT	2	L	01	X11	D
Series	Cable or connector	Cable or connector direction	Head and actuators	Contact Types	Distance between fixing holes
	2 - 2 mt X - Other lenght on request M - M12 connector	L - Side V - Vertical	01 - Steel end plunger 02 - Roller plunger 03 - 90° Roller plunger 04 - Metal revolving lever Ø 17.5 nylon roller 05 - Adjustable lenght straight metal revolving lever Ø 17.5 nylon roller 06 - Steel end plunger with threaded flange 07 - Roller plunger with threaded flange 08 - 90° Roller plunger with threaded flange 09 - Steel end plunger with rubber protection 10 - Rod lever type 11 - Spring lever with tip in PA	X11 - 1NC/1NO Slow Action Z11 - 1NC/1NO Snap Action	D - 20 mm

01: Steel end plunger

FCT	M	L	01	X11	D
Series	Cable or connector	Cable or connector direction	Head and actuators	Contact Types	Distance between fixing holes
	2 - 2 mt X - Other lengths on request M - M12 connector	L - Side V - Vertical	01 - Steel end plunger	X11 - 1NC/1NO Slow Action Z11 - 1NC/1NO Snap Action	D - 20 mm

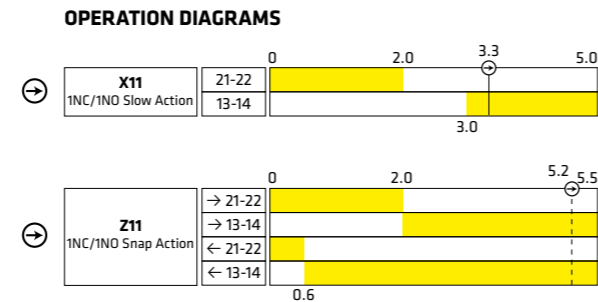
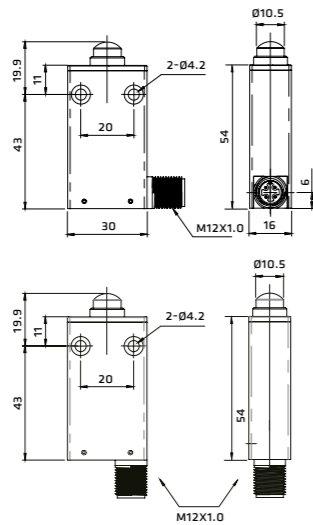

AVAILABLE VERSIONS

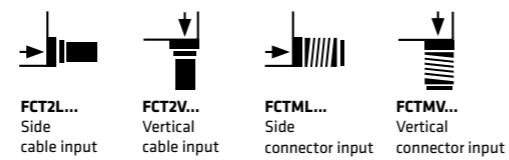

03: 90° Roller plunger

FCT	M	L	03	X11	D
Series	Cable or connector	Cable or connector direction	Head and actuators	Contact Types	Distance between fixing holes
	2 - 2 mt X - Other lengths on request M - M12 connector	L - Side V - Vertical	03 - 90° Roller plunger	X11 - 1NC/1NO Slow Action Z11 - 1NC/1NO Snap Action	D - 20 mm

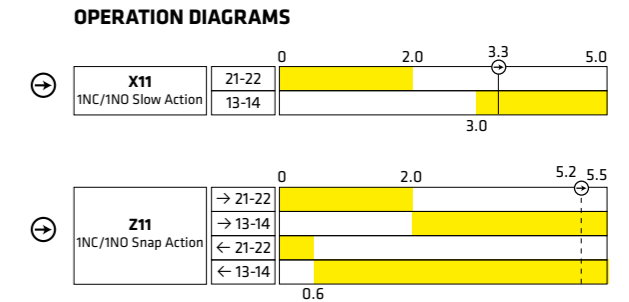
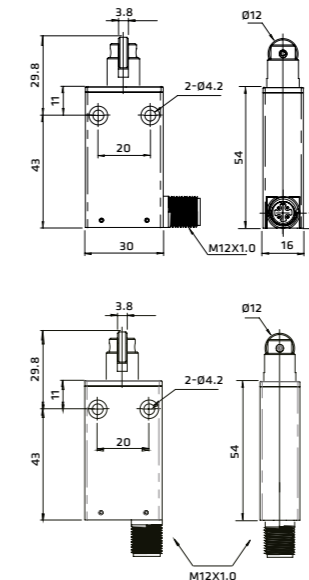

AVAILABLE VERSIONS

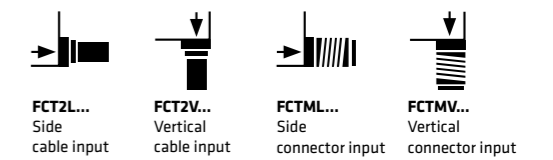

02: Roller plunger

FCT	M	L	02	X11	D
Series	Cable or connector	Cable or connector direction	Head and actuators	Contact Types	Distance between fixing holes
	2 - 2 mt X - Other lengths on request M - M12 connector	L - Side V - Vertical	02 - Roller plunger	X11 - 1NC/1NO Slow Action Z11 - 1NC/1NO Snap Action	D - 20 mm

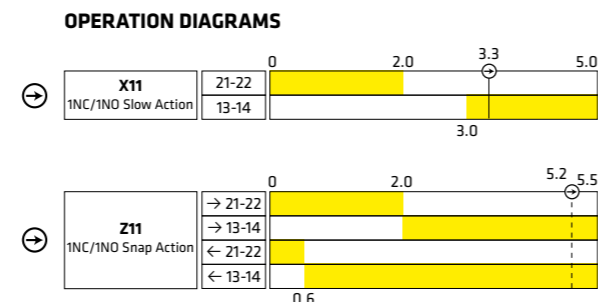
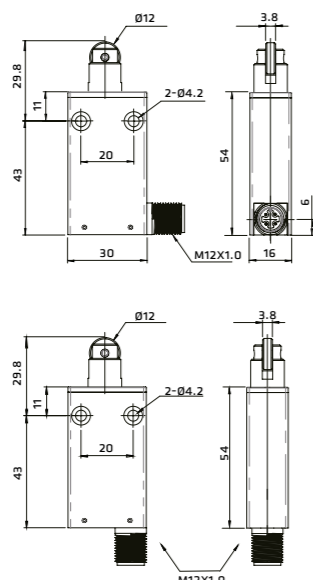

AVAILABLE VERSIONS

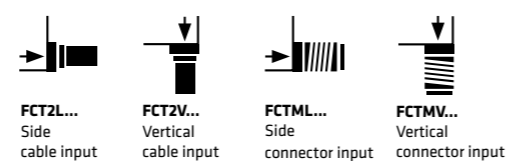

04: Metal revolving lever Ø17.5 nylon roller

FCT	M	L	04	X11	D
Series	Cable or connector	Cable or connector direction	Head and actuators	Contact Types	Distance between fixing holes
	2 - 2 mt X - Other lengths on request M - M12 connector	L - Side V - Vertical	04 - Metal revolving lever Ø17.5 nylon roller	X11 - 1NC/1NO Slow Action Z11 - 1NC/1NO Snap Action	D - 20 mm

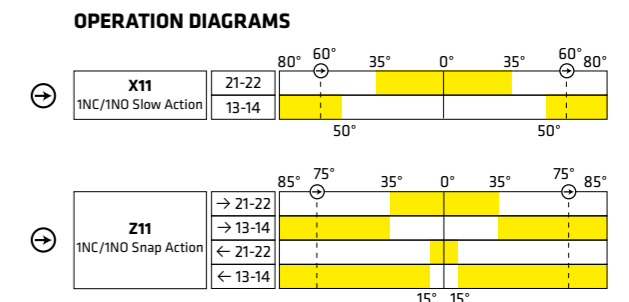
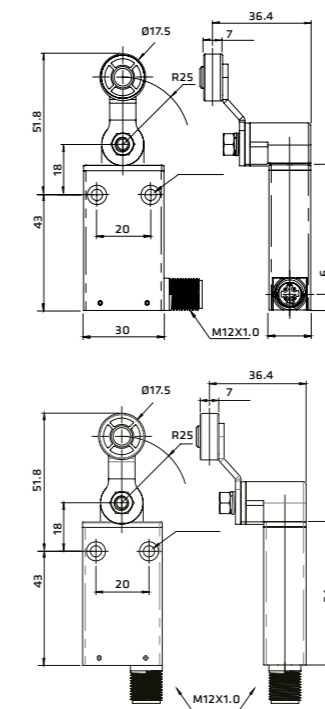

AVAILABLE VERSIONS

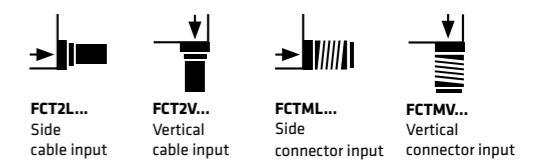

05: Adjustable length straight metal revolving lever Ø17.5 nylon roller

FCT	M	L	05	X11	D
Series	Cable or connector	Cable or connector direction	Head and actuators	Contact Types	Distance between fixing holes
	2 - 2 mt X - Other lengths on request M - M12 connector	L - Side V - Vertical	05 - Adjustable length straight metal revolving lever Ø 17.5 nylon roller	X11 - 1NC/1NO Slow Action Z11 - 1NC/1NO Snap Action	D - 20 mm

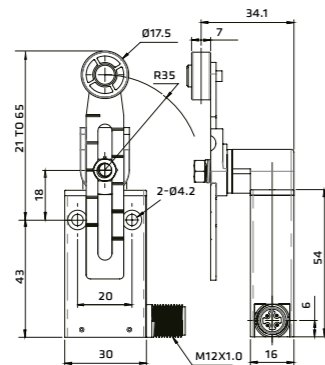

OPERATION DIAGRAMS

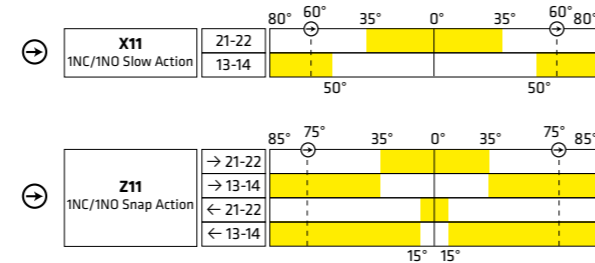

AVAILABLE VERSIONS

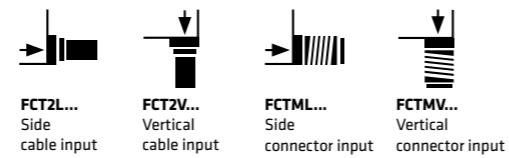

07: Roller plunger with threaded flange

FCT	M	L	07	X11	D
Series	Cable or connector	Cable or connector direction	Head and actuators	Contact Types	Distance between fixing holes
	2 - 2 mt X - Other lengths on request M - M12 connector	L - Side V - Vertical	07 - Roller plunger with threaded flange	X11 - 1NC/1NO Slow Action Z11 - 1NC/1NO Snap Action	D - 20 mm

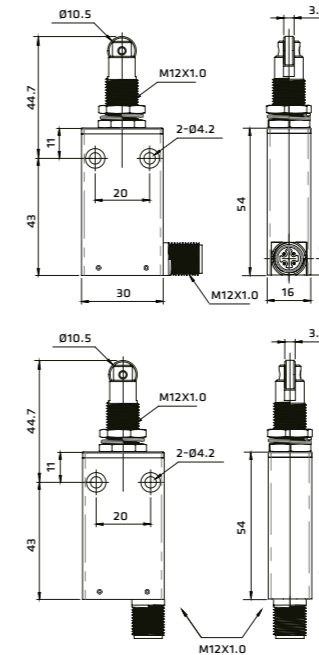

OPERATION DIAGRAMS

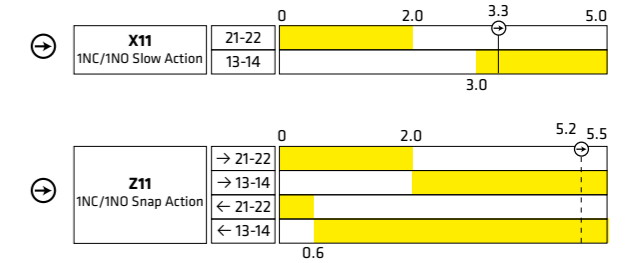

AVAILABLE VERSIONS

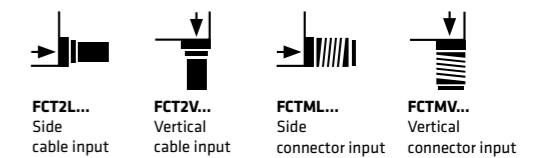

06: Steel end plunger with threaded flange

FCT	M	L	06	X11	D
Series	Cable or connector	Cable or connector direction	Head and actuators	Contact Types	Distance between fixing holes
	2 - 2 mt X - Other lengths on request M - M12 connector	L - Side V - Vertical	06 - Steel end plunger with threaded flange	X11 - 1NC/1NO Slow Action Z11 - 1NC/1NO Snap Action	D - 20 mm

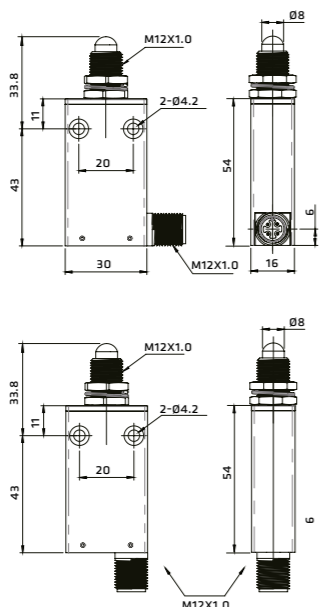

OPERATION DIAGRAMS

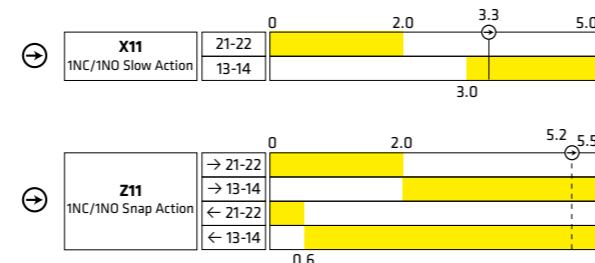

AVAILABLE VERSIONS

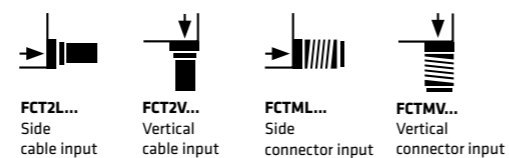

08: 90° Roller plunger with threaded flange

FCT	M	L	08	X11	D
Series	Cable or connector	Cable or connector direction	Head and actuators	Contact Types	Distance between fixing holes
	2 - 2 mt X - Other lengths on request M - M12 connector	L - Side V - Vertical	08 - 90° Roller plunger with threaded flange	X11 - 1NC/1NO Slow Action Z11 - 1NC/1NO Snap Action	D - 20 mm

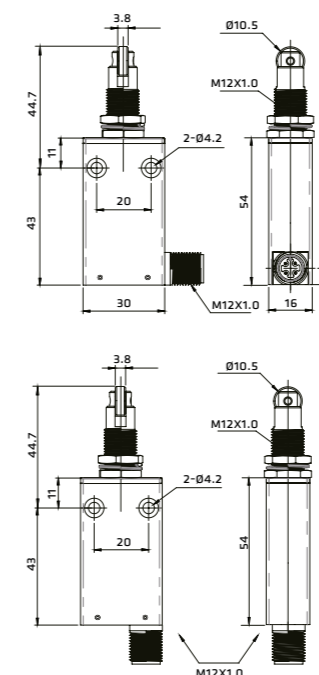

OPERATION DIAGRAMS

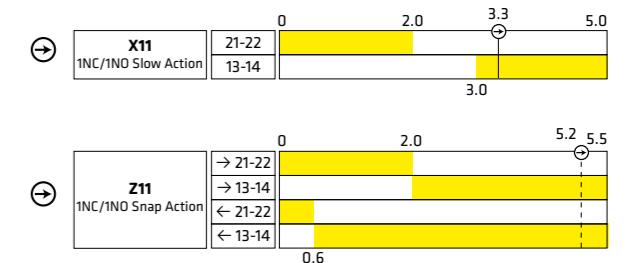

AVAILABLE VERSIONS

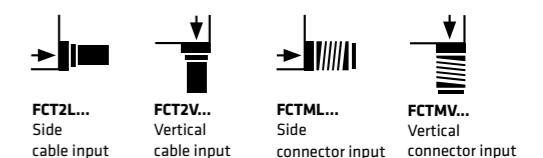

09: Steel end plunger with rubber protection

FCT	M	L	09	X11	D
Series	Cable or connector	Cable or connector direction	Head and actuators	Contact Types	Distance between fixing holes
	2 - 2 mt X - Other lengths on request M - M12 connector	L - Side V - Vertical	09 - Steel end plunger with rubber protection	X11 - 1NC/1NO Slow Action Z11 - 1NC/1NO Snap Action	D - 20 mm

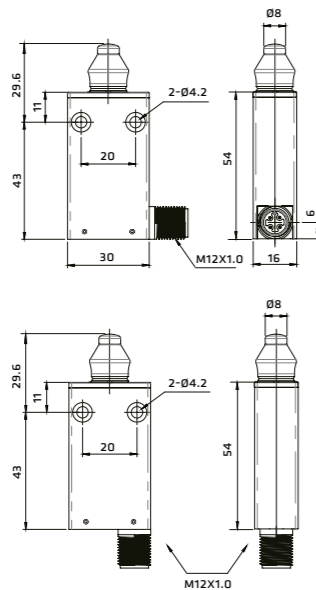

OPERATION DIAGRAMS

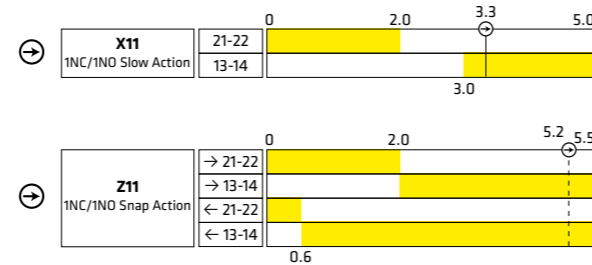

AVAILABLE VERSIONS

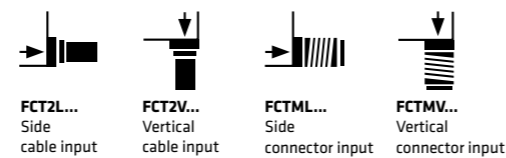

11: Spring lever with tip in PA

FCT	M	L	11	X11	D
Series	Cable or connector	Cable or connector direction	Head and actuators	Contact Types	Distance between fixing holes
	2 - 2 mt X - Other lengths on request M - M12 connector	L - Side V - Vertical	11 - Spring lever with tip in PA	X11 - 1NC/1NO Slow Action Z11 - 1NC/1NO Snap Action	D - 20 mm



OPERATION DIAGRAMS... Coming soon

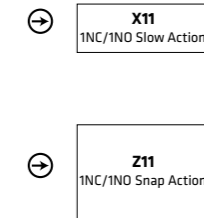

AVAILABLE VERSIONS

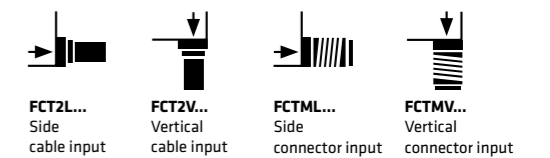

10: Rod lever type

FCT	M	L	10	X11	D
Series	Cable or connector	Cable or connector direction	Head and actuators	Contact Types	Distance between fixing holes
	2 - 2 mt X - Other lengths on request M - M12 connector	L - Side V - Vertical	10 - Rod lever type	X11 - 1NC/1NO Slow Action Z11 - 1NC/1NO Snap Action	D - 20 mm

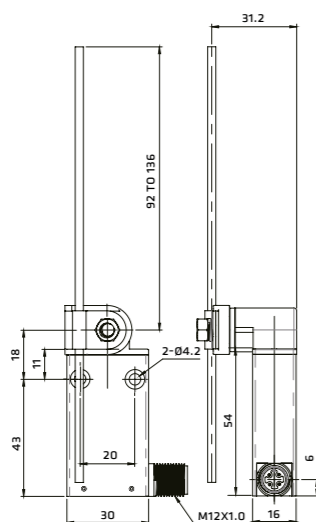

OPERATION DIAGRAMS

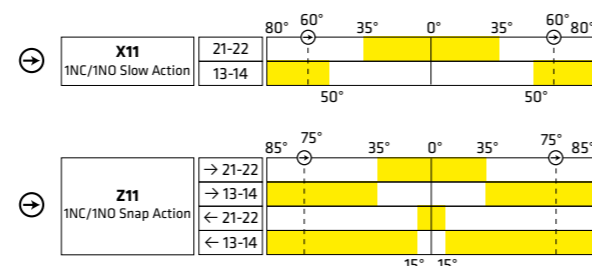

AVAILABLE VERSIONS

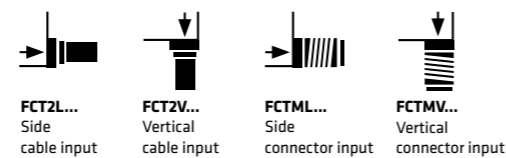

OPERATING FORCE FCT SERIES

TYPE	CONTACT BLOCK			OF max	RF min	TT min	PT max	OT min	MD max	OP ±1mm
01	X11	1 NC/1 NO Slow Action	NC NO	1200 g	400 g	5 mm	2 mm 3 mm	3.8 mm 3 mm	N/A	17.3 mm 16.3 mm
	Z11	1 NC/1 NO Snap Action	NC NO	1500 g	300 g	5 mm	2.5 mm	3 mm	2 mm	16.8 mm
02	X11	1 NC/1 NO Slow Action	NC NO	1200 g	400 g	5 mm	2 mm 3 mm	3.8 mm 3 mm	N/A	28.3 mm 27.3 mm
	Z11	1 NC/1 NO Snap Action	NC NO	1500 g	300 g	5 mm	2.5 mm	3 mm	2 mm	27.8 mm
03	X11	1 NC/1 NO Slow Action	NC NO	1200 g	400 g	5 mm	2 mm 3 mm	3.8 mm 3 mm	N/A	28.3 mm 27.3 mm
	Z11	1 NC/1 NO Snap Action	NC NO	1500 g	300 g	5 mm	2.5 mm	3 mm	2 mm	27.8 mm
04	X11	1 NC/1 NO Slow Action	NC NO	1000 g	150 g	80°	35° 50°	45° 35°	N/A	N/A
	Z11	1 NC/1 NO Snap Action	NC NO	1000 g	100 g	80°	45° 40°	25° 60°	30°	N/A
05	X11	1 NC/1 NO Slow Action	NC NO	1000 g	150 g	80°	35° 50°	45° 35°	N/A	N/A
	Z11	1 NC/1 NO Snap Action	NC NO	1000 g	100 g	80°	45° 40°	25° 60°	30°	N/A
06	X11	1 NC/1 NO Slow Action	NC NO	1200 g	400 g	5 mm	2 mm 3 mm	3.8 mm 3 mm	N/A	32.3 mm 31.3 mm
	Z11	1 NC/1 NO Snap Action	NC NO	1500 g	300 g	5 mm	2.5 mm	3 mm	2 mm	31.8 mm
07	X11	1 NC/1 NO Slow Action	NC NO	1200 g	400 g	5 mm	2 mm 3 mm	3.8 mm 3 mm	N/A	43.2 mm 42.2 mm
	Z11	1 NC/1 NO Snap Action	NC NO	1500 g	300 g	5 mm	2.5 mm	3 mm	2 mm	42.7 mm
08	X11	1 NC/1 NO Slow Action	NC NO	1200 g	400 g	5 mm	2 mm 3 mm	3.8 mm 3 mm	N/A	43.2 mm 42.2 mm
	Z11	1 NC/1 NO Snap Action	NC NO	1500 g	300 g	5 mm	2.5 mm	3 mm	2 mm	42.7 mm
09	X11	1 NC/1 NO Slow Action	NC NO	1200 g	400 g	5 mm	2 mm 3 mm	3.8 mm 3 mm	N/A	27.1 mm 26.1 mm
	Z11	1 NC/1 NO Snap Action	NC NO	1500 g	300 g	5 mm	2.5 mm	3 mm	2 mm	26.6 mm

OPERATING FORCE FCT SERIES

TYPE	CONTACT BLOCK			OF max	RF min	TT min	PT max	OT min	MD max	OP ±1mm
10	X11	1 NC/1 NO Slow Action	NC NO	1000 g	150 g	80°	35° 50°	45° 35°	N/A	N/A
	Z11	1 NC/1 NO Snap Action	NC NO	1000 g	100 g	80°	45° 40°	25° 60°	30°	N/A
11	X11	1 NC/1 NO Slow Action	NC NO	-	-	-	-	-	-	-
	Z11	1 NC/1 NO Snap Action	NC NO	-	-	-	-	-	-	-

Coming soon!

