

For emergency stop locations see page 4.

Note: Lanyards are to be fitted in front of removable guards, nip and shear points that are accessible on all bulk handling material conveyors and not to be replacements for guards.

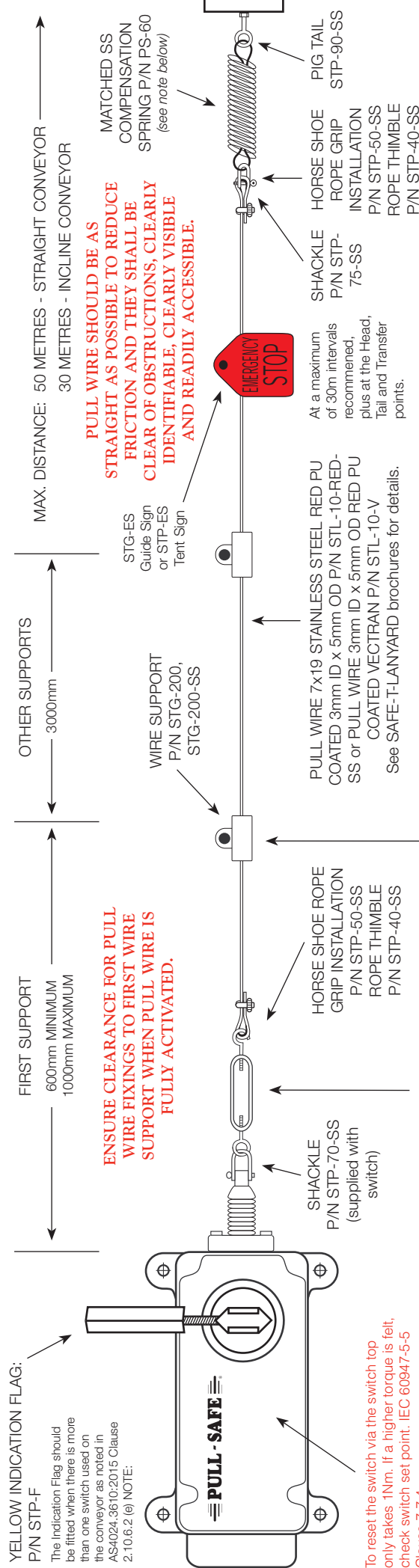

**PULL WIRE SHOULD BE AS STRAIGHT AS POSSIBLE TO REDUCE FRICTION AND THEY SHALL BE CLEAR OF OBSTRUCTIONS, CLEARLY IDENTIFIABLE, CLEARLY VISIBLE AND READILY ACCESSIBLE.**

**ENSURE CLEARANCE FOR PULL WIRE FIXINGS TO FIRST WIRE SUPPORT WHEN PULL WIRE IS FULLY ACTIVATED.**

To reset the switch via the switch top only takes 1Nm. If a higher torque is felt, check switch set point. IEC 60947-5-5 Clause 7.7.4

NOTE: After actuation and before resetting, the machinery shall be inspected along the whole length of the rope in order to detect the reason for activation. AS4024.1604 Clause 4.54

TURNBUCKLE P/N STP-20-SS  
NOTE: Turnbuckle MUST have Locking Nuts fitted.  
(Can be mounted at remote end of Pull Wire)

NOTE: - FIRST SUPPORT MUST BE ON CENTRE LINE OF SWITCH PULL ROD

For further installation requirements refer to AS/NZS 4024-1-2014 Series: Safety of Machinery.

NOTE: To comply with the safety critical functions in AS/NZS 4024.3610 - 2015 Section 2.10.5 Emergency Stop.

The locations of Pull Wires, components and elements to achieve the emergency stop function, person - on - conveyor stop, general requirements and Pull Wire design must all be reviewed before installation. In reviewing this, a balance matched compensation spring must be fitted to the remote ends of the taut wire system so that the system may work in all directions correctly. The PULL-SAFE switch has its own balance matched compensation spring that will only work on this SAFE-T-PRODUCTS device.

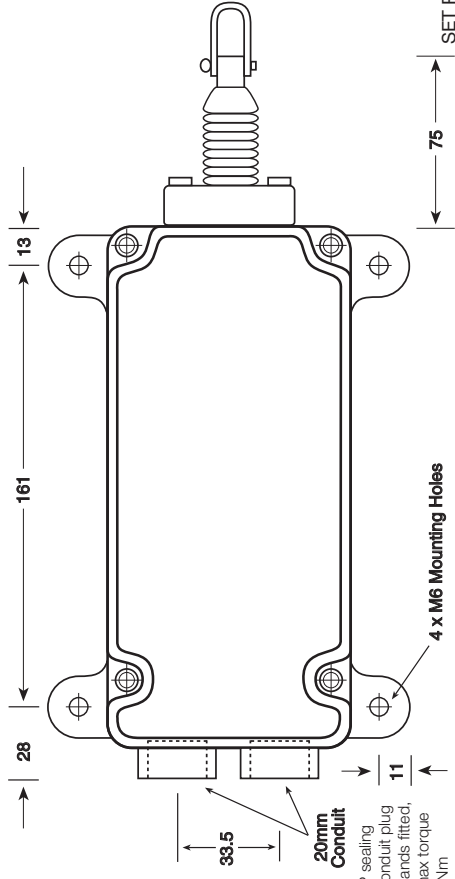
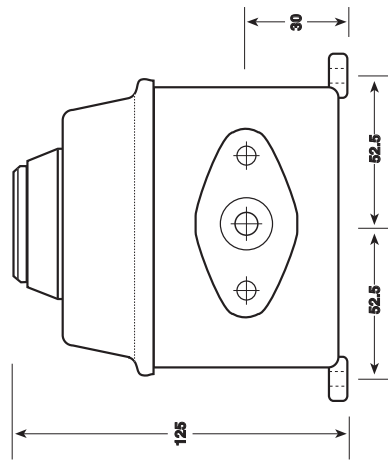

**SWITCH CANNOT BE RESET UNTIL PULL WIRE IS CORRECTLY TENSIONED**  
ie. 75mm from pull rod end to switch body.

SET POSITION  
Use set up gauge supplied with switch.  
SET Point ± 8mm



ACN: 060 617 987



## **Standards**

The **≡ PULL - SAFE ≡** complies with the relevant parts of these Standards:

IEC 60947-5-1 Ed 3.1	Control circuit devices & switching elements
AS/NZS IEC 60947-5-1:2015	Control circuit devices & switching elements
IEC 60947-5-5 Ed 1.1	Control circuit devices & switching elements-Electrical emergency stop devices with mechanical latching function.
AS/NZS IEC 60947.5.5:2015	Control circuit devices & switching elements-Electrical emergency stop devices with mechanical latching function.
AS/NZS 4024.1-2014	Safety of Machinery.
AS/NZS 4024.3610:2015	Safety of Machinery, conveyors, general requirements.
AS/NZS 4024.3611:2015	Safety of Machinery, conveyors, belt conveyors for bulk materials handling.

## **Ce Conformity to:**

2006/42/EC	Machinery Directive
2014/35/EU	Low Voltage Directive

## **Workshop Tested**

All switches are either hand or robotically tested by trained technicians before leaving ELECTRIC CONTROL PRODUCTS and have a date and name label of manufacture inside them. The switches are then packed insuring full working order to our stringent test parameters. A certification certificate is available on request for full compliance to the relevant standards.

## **Modifications of Switch**

Any modifications are **ONLY** to be made by ELECTRIC CONTROL PRODUCTS or one of their registered repairers. Any unauthorized modifications may not comply with the relevant standards and may diminish the integrity and workings of the switch and the warranty will become void.

ELECTRIC CONTROL PRODUCTS and their registered repairers or distributors will not be responsible for any damage caused to the altered switch or any item in, on, related or near the switch, nor any injury incurred, nor actions resulting from the unauthorized alterations.

## **Returns Policy/ Re Stocking**

Please return any defective switch to place of purchase for assessment. If they are deemed to be warranty repairs or not. Return warranty switches as per warranty clause. Restocking returns will only be accepted if received by ELECTRIC CONTROL PRODUCTS in their original condition and within thirty (30) days of delivery date stated on delivery documentation. A restocking fee applies (contact place of purchase for costs).

## **Warranty**

Electric Control Products of Perth Western Australia contact [sales@safe-t-products.com.au](mailto:sales@safe-t-products.com.au) warranty period is Twenty Four (24) months from date of purchase or longer if indicated by Electric Control Products. For warranty to be valid the goods must be received by Electric Control Products before the end of the Twenty Four (24) month period. Electric Control Products warrants that if any product is defective, it will, at its option, replace or repair the product. **This warranty shall not apply to any defect which arises from improper use, failure to follow the products instruction, or any repair or modification made without the consent of Electric Control Products.**

The customer must contact the Distributor of the product or Electric Control Products of Perth Western Australia via Email [sales@safe-t-products.com.au](mailto:sales@safe-t-products.com.au) before returning the faulty product. If returned they must be suitably packaged and, where relevant, returned in accordance with any particular instructions which Electric Control Products or one of its distributors may have notified the customer at the time of contact for warranty. **Returned products must be accompanied by an advice note stating the nature of any defect being claimed.** Any products or parts which are replaced by Electric Control Products or one of its distributors shall become the property of Electric Control Products. **Title to replacement products shall pass to the customer on delivery, and the period of the warranty shall be calculated from the date of the defective product.**

All warranty returns to Electric Control Products will be sent by the customer's freight at their cost. All benefits under this warranty are in addition to other rights and remedies of the consumer under a law in relation to the goods or services to which the warranty relates. Our goods come with guarantees that cannot be excluded under the Australian Consumer Law. You are entitled to a replacement or refund for a major failure and for compensation for any other reasonably foreseeable loss or damage. You are also entitled to have the goods repaired or replaced if the goods fail to be of acceptable quality and the failure does not amount to a major failure.

## Product Life Expectancy

Electric Control Products **estimate** the product life expectancy to 10-15 years.

A shorter or longer product life maybe experienced due to environmental situations.

Electric Control Products can't give a written life expectancy on any of it's products due to the different situations the products are used.

## Technical Support

Technical advice will be given at any time by Electric Control Products or Distributor on any of the Electric Control Product range. Contact Electric Control Products or your local Distributor for this service.

## Obsolete Products

Notification will be given to Distributors only for the products becoming obsolete and a time frame of when this will occur. Please contact Distributors for this information.

The Obsolete product range will have spare parts for 12 months after becoming obsolete or until they run out, complete products will be available for a short time after it has become obsolete.

## Location Of Emergency Stops

Emergency stops shall be located at each operator control station and other locations where emergency stop is required.

Conveyors not greater than 2.5m in length and less than 2.7m above the floor, walkway or platform. A single stop control at a location which is easily accessible by the operator is all that is needed.

Conveyors greater than 2.5m in length and less than 2.7m above the floor, walkway or platform. They must have an emergency stop at the head, tail, drive and intervals not exceeding 30m along the length of the conveyor. Overland and long conveyors must have emergency stops every 30m so lanyards are advised to be used for best coverage for safety critical function.

Conveyors greater than 2.7m above the floor, walkway or platform. Locate emergency stops at positions where accessible and at intervals not exceeding 100m along the conveyor. Lanyards or Emergency Stop buttons may be used.

Emergency stop at positions adjacent to the conveyor where it can be started.

Emergency stop at every permanent working station.

## Maintenance Procedure

All switches require minimal maintenance but as found in AS/NZS 4024.1:2014 a maintenance procedure SHALL be carried out.

**Quick visual and measurement safety maintenance procedure at 3 Month recommended intervals, or as per Applied Risk Assessment. NOTE: This inspection procedure is only a quick visual check and maybe done from a short distance away. Quick measurements maybe needed to determine positions of spring extension and pull rod position. If worn parts are found then a axis test may need to be done to determine if the parts need to be changed urgently or only an adjustment is needed to be done.**

1. Inspect compensation spring for dirt build up.
2. Check that the switch is installed as per installation instructions.
3. Visual inspection of enclosure to ensure IP rating and correctly operating device i.e. Damaged enclosure, bent pull rod, damaged dust boot etc.

### TEST1 Axis Pull Wire Test

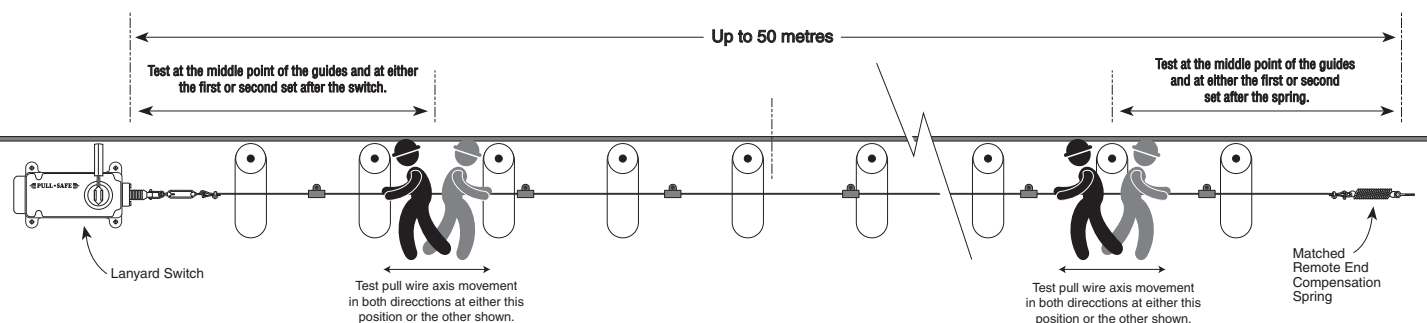

4. Check that the pull rod is tensioned to the set position as per installation instructions, using either tape measure/ruler or PS-SUG gauge supplied with the switch. (See page 1 for information)
5. Inspect all attachments are tight, free from obstructions and not worn and replace if necessary.
6. Inspect pull wire supports for wear, deterioration and build up of material, replace if necessary.  
NOTE: Pigtails and Eyebolts make very high static friction points and cause excessive wear and system disruption. Electric Control Products recommends the STG-200 SAFE-T-GUIDE for critical safety function.
7. Inspect pull wire for wear or deterioration and replace if necessary.

### Full Safety maintenance procedure at 12 Month recommended intervals, or as per Applied Risk Assessment

**System testing note: Tests 1 & 2 are most efficiently run at the same time with 2 personnel walking the conveyor. A 50m pull wire system should take 5-10 min to test. One person walks to the lanyard switch and the other person stands at the spring and initiates test 1 “Axis Pull Wire Test”. Once the switch trips it is reset, then another test 1 is done in the same place but the opposite direction. The switch is then reset again. Then test 2, the “90 degree pull wire test” is initiated and tested at the spring end, at the pull wire system center between the spring and switch and the switch end as shown in test 2 below. These test measurements are called out by the tester to the person at the switch. The person at the switch will reset the switch and then document the measurements while the other person moves to the next position for test.**

1. Test that the Lanyard operates as per stated in AS/NZS 4024.3610-2015 Clause 2.10.6.2

The test needs to be conducted along the axis of the pull wire in both directions. Pull the wire along the axis until the switch trips making sure the wire moves freely and easily.

This must be done at intervals at the centre of pull wire’s length, 3m-4m from the switch and 3m-4m from the compensation spring in both directions (See Figure 1). After each trip the switch will need to be reset before the next axis trip test is to be conducted.

If the pulling of the wire is hard then check the installation, if the problem is still present contact the supplier of the product for advice. NOTE: Keeping the pull wire straight or making sure to use long curved bends or STG-200-RG- SS roller guides to bend around corners should keep the pull parameters in check.

Reset the  and attach calibrated SAFE-T- SCALES or some other calibrated weight measurement device to the pull wire (See Figure 2), 90 degrees to the pull wire axis. A length measurement needs to be taken as well in this test. The test needs to be conducted 90 degrees to the pull wire’s axis at the same positions as test 1 and at the center, between supports (See Figure 2).

Pull the wire 90 degrees to the axis quickly and using the calibrated SAFE-T-SCALE or some other calibrated weight measurement device, measure the amount of force it takes to trip the switch. There will be some over pull in this test so factor this into the measurement. Once the switch trips check to see how far the pull wire needs to be pulled to activate a trip. An easy way to take this measurement when pulling the wire with the scales attached is start with your arm out stretched and pull quickly towards you stopping when your arm is bent 90 degrees next to your side, this measurement is about 400-450 mm. Note, the pulling speed of the test will have an effect on the test results. As the wire is moving the whole length, faster the pull the lower the test result due to the reduction of the static friction between the rope and guides. In an emergency situation, the switch will not be pulled slowly so the test should replicate this. AS 4026.3610 state the force used to activate a trip must not exceed 70N (7Kg) and the amount of pull should not exceed 300mm. Note: Electric Control Products risk assessment recommends a pull distance of up-to 450mm and a maximum of 200 N, AS4024.1604 allows this recommendation. Attention must be paid to the surrounding environment and if this distance may be achieved safely. The Ergonomics HB-59 standard gives an average human arm reach distance of 500mm so 450mm pull distance would be acceptable. If the problem is still present contact the supplier of the product for advice.

**NOTE:** If these parameters are higher than what is stated then the installation may need to be changed. Contact Electric Control Products for information on conveyor audits and installation instructions.

If Eyebolts or Pigtailed are being used, then this could be a factor as they increase the Pull Wire friction and can give high readings. Obstructions or sharp radius bends increase friction and give high readings, the use of the roller guide (STG-200-RG-SS) is recommended. Incorrect compensation spring or the switch is seized or not working correctly could be the under laying problem. The pull parameters are also governed by the positions of the rope guides and the position of the set point of the pull rod. If the rope guides are further apart than 3m then the Nm of force to pull the wire 90 degrees will decrease but the overall pull out length will increase and this is reversed if the guides are closer than 3m. Adjust the pull rod set point position out by 5-10mm (105-110mm) for shorter pull out tripping distance. This may increase nuisance tripping if not using STL-10-V pull wire.

## TEST 2 90 Degree Pull Wire Test

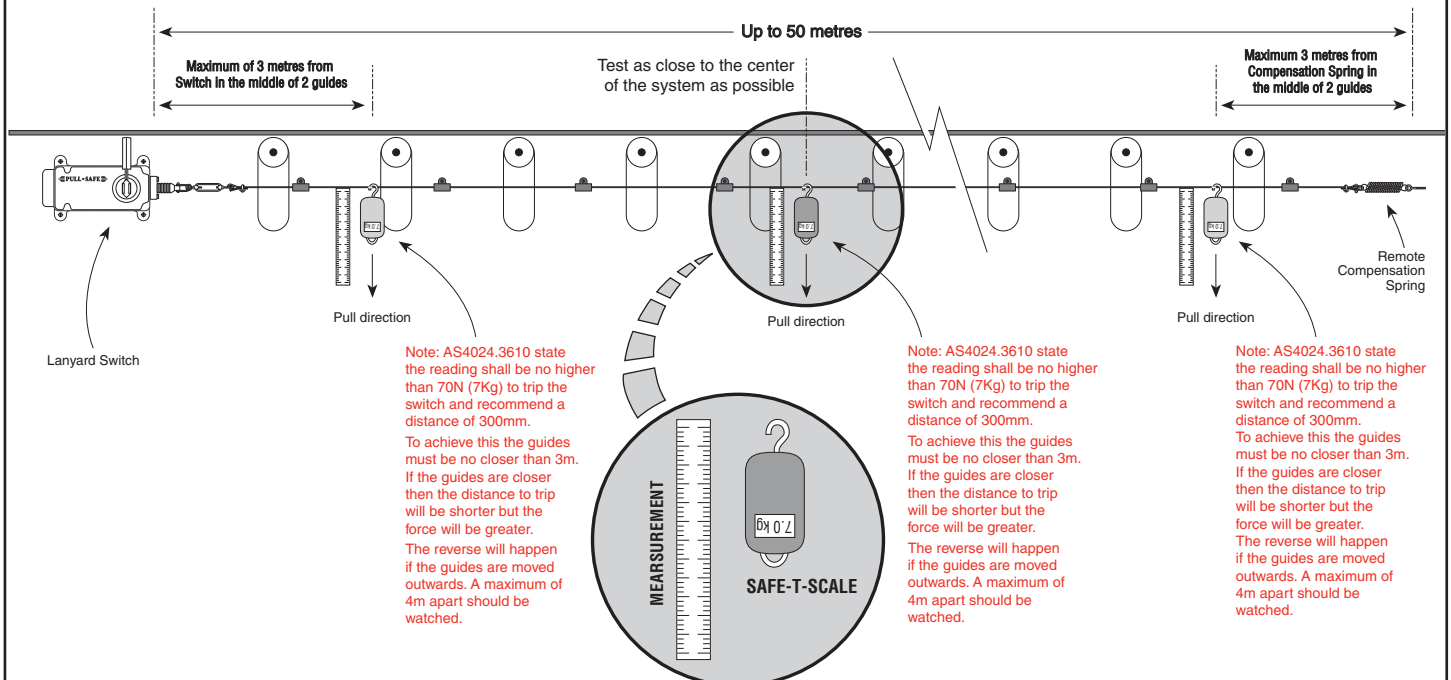

1. After activation test, check that the set position of the pull rods are as per installation instructions, if not readjust turnbuckle so the pull rods are at the set position and redo step 8-9.
2. If the switch or system is not working correctly either contact Electric Control Products for site assessment or return the switch to an authorized distributor for assessment. Maybe be replaced or repaired if under warranty.

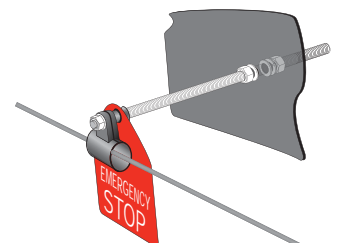

## TECHNICAL DATA

### POSITIVE BREAK TYPE

Performance to VDE 0660, part 200 7/92 (EN 60947, IEC 947.
Direct positive opening.
Long overtravel after direct positive opening.
Type A, DIN 41636
Protection degree IP 40
Self cleaning contact pieces

### CONTACT FORM - SPDT

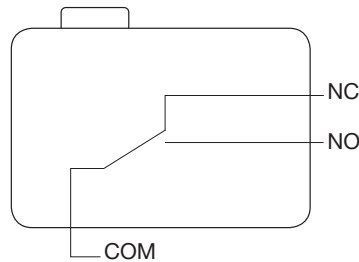

### TECHNICAL DATA

Permanent current	6A (max. 10A)
Breaking capacity	AC 15 250 V AC/1,5A
Insulation	4kV/3
Contact type	NC/NO/change over
Mechanical life	10 million operations
Temperature range	-40°C to +85°C

### Contacts shown are in the Lanyards Set Position

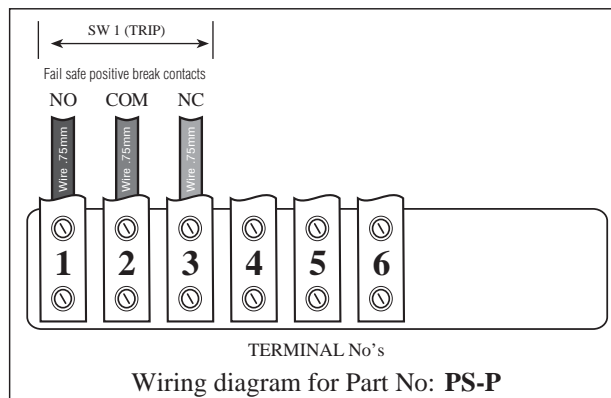

### Contacts shown are in the Lanyards Set Position

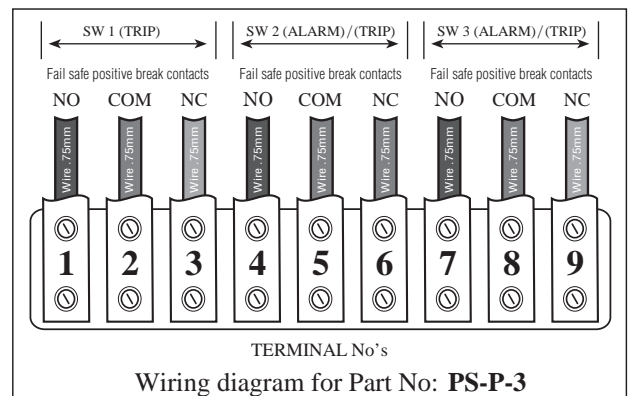
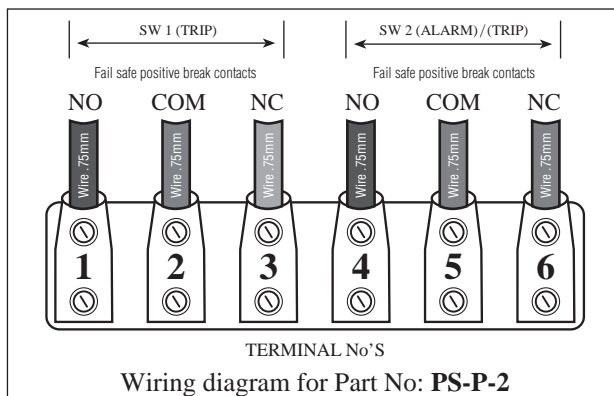

**P/N PS -P**

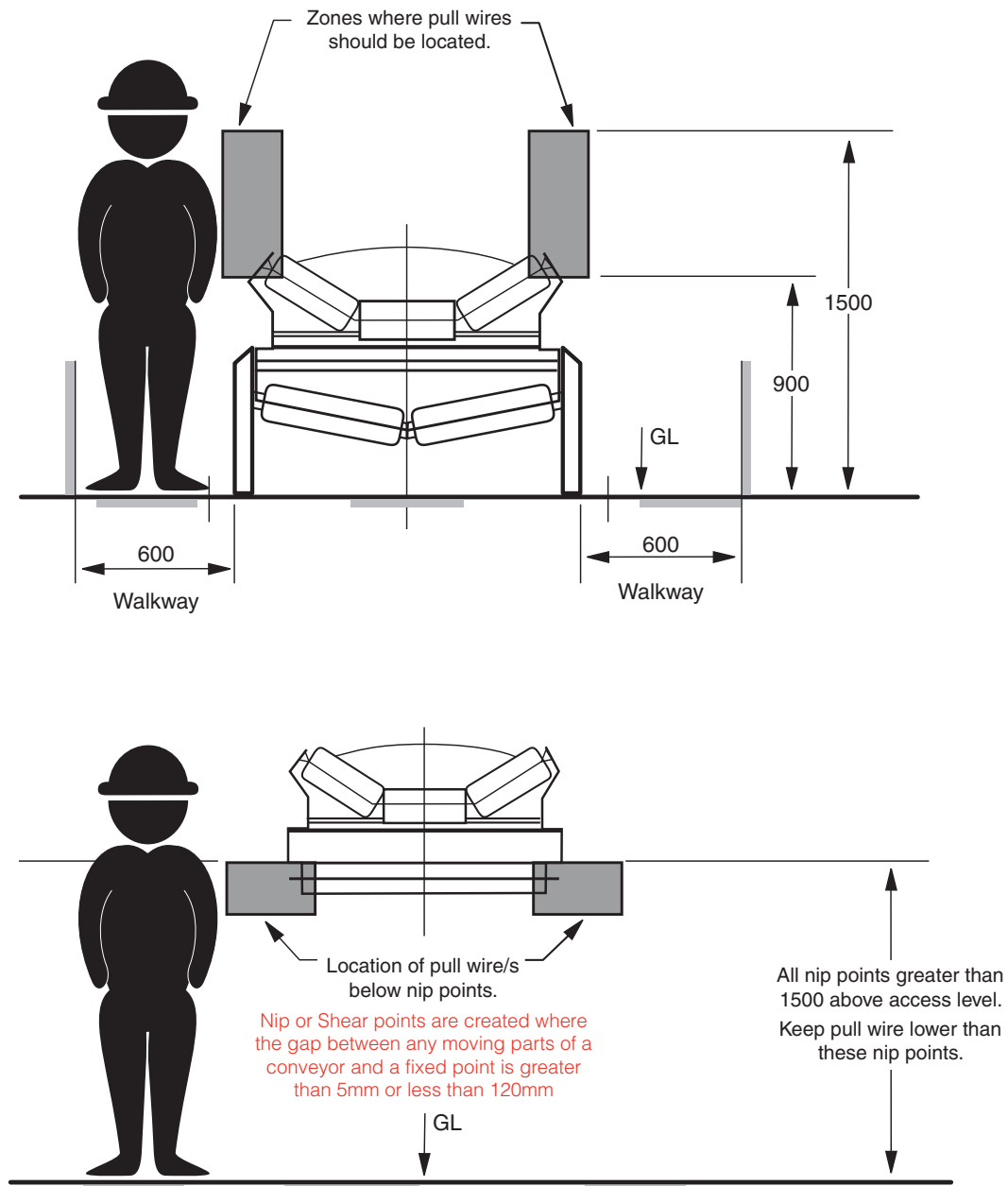

Use STP-NPG Nip Point Gauge to check distances between parts.  
Note: Conveyor shall be isolated before task is undertaken.

## Locations of Pull Wires

The design risk assessment shall determine the most favourable location for the pull wire systems location.

Where practicable, pull wires should be in such a manner that they are, clearly visible, adding signs or colour of pull wires can help. Readily accessible for any personnel that potentially may become trapped in a danger area or any personnel that may be nearby. Outside any readily removable guard and external to the vertical line of any nip or shear point. They should be no further than 1m from the nip or shear point.

At least 900 mm above the access floor. Should be no more than 1500 mm above the access floor. Where required to be higher than 1500 mm, the pull wire system should be located lower than the nip or shear points.

Also, the consideration of the potential for a person to inadvertently be on a moving conveyor, the severity of injury to a person due to this event and whether a risk control needs to be in place.

Electric Control Products recommends the "Collide Safe" Man-On-Belt switch for this application.

## ASNZS 4024.3611

### Bulk Handling Material Conveyors: Location of Emergency Stops

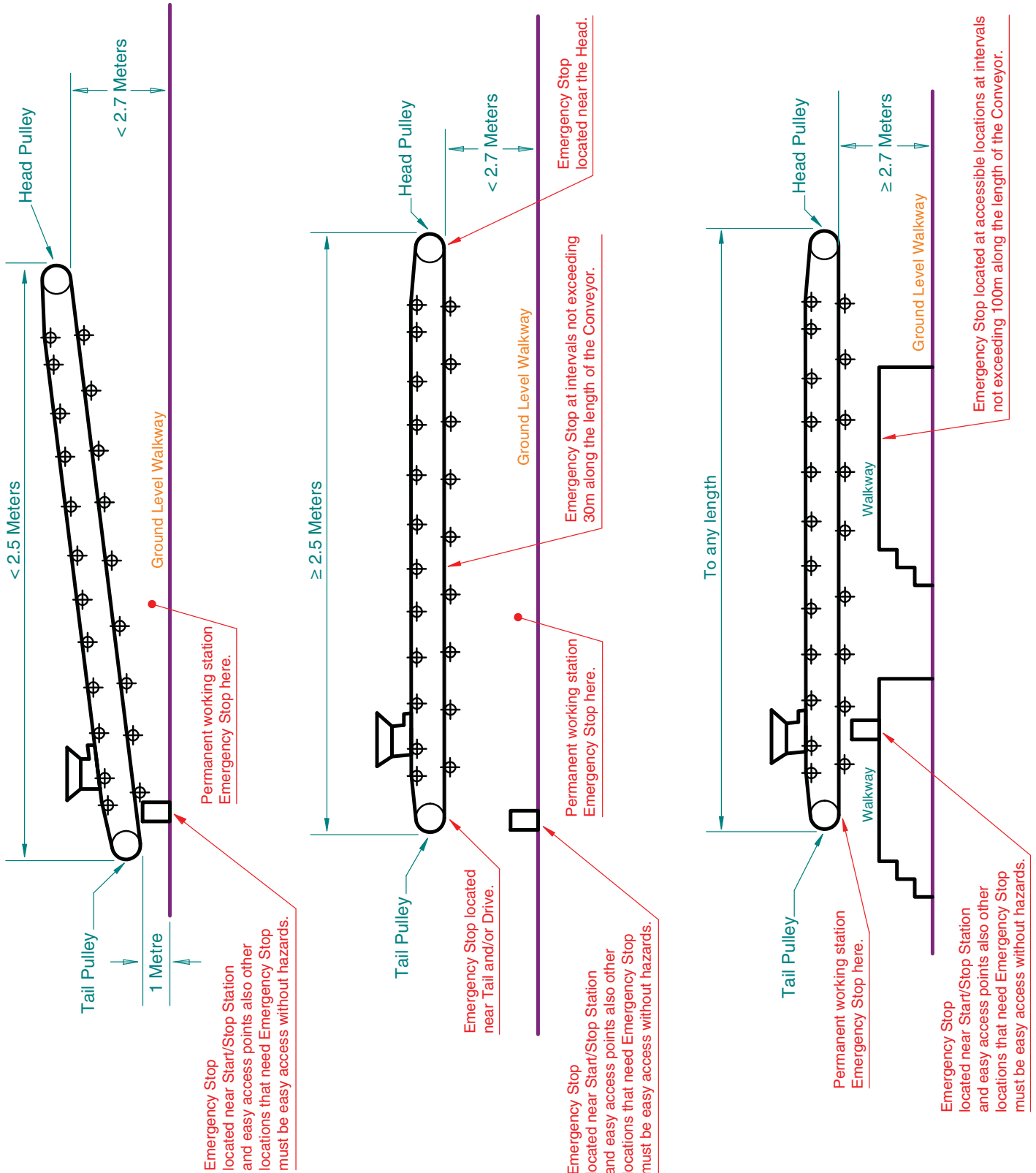

**Note:** Consideration shall be given for the provision of an emergency stop at the take-up where the take-up is on another level or remote from the main drive.