

V25 SERIES VISUAL INDICATORS FOR FLOW AND LEVEL MONITORING

MODEL V25F-SS



V25F FLOW INDICATOR

For flow applications the V25 visual indicator is supplied with a flow-sensing paddle suitable for use in pipes both large and small. Designated V25F, the visual flow indicator is a self-powered magnetically operated insertion indicator that can be used in pipes ranging from 25mm (1") upward. The indicator simply screws into a standard pipe tee or socket and provides a clear bright red or green face as an indication of flow or lack of flow.

The V25F flow indicator is available with a normally red face that changes to green when flow is detected. Normally red is the standard configuration and is supplied as the default model unless otherwise specified. The indicator is also available with a normally green face that changes to red when flow is detected. The reversed colour models can be used to indicate danger when flow is present.

Visual flow indicators generally have heavy glass or plastic pressure windows that allow an operator to view the process liquid. The V25F uses a unique coloured flag to indicate flow or lack of flow. The flag operates magnetically in a sealed see through chamber. There are no pressure windows to fail in the V25F flow indicator. The V25F can be used in coloured or turbid liquids. It can also be used in air and gases and in liquids containing solids. When fitted with a suitable trailing wire sensor it can even be used in effluent and sewage applications.

V25L TANK LEVEL INDICATOR

For tank level monitoring, the V25 visual indicator is supplied with a float and arm suitable for installing through the sidewall of a tank. Designated V25L the float level indicator is ideal for non-electrical level indication in water, chemical and diesel fuel tanks. The V25L is available with a normally green or a normally red face. The indicator must be ordered with the correct coloured face for the intended application. As an example, for a low level indicator the V25L would be ordered as NR, (Normally Red). When the level is above the indicator the face of the NR indicator will be green indicating all is OK. It will change to red indicating low level if the level drops below the indicator. For a high-level indicator application the V25L should be ordered as NG (Normally Green). The face of this indicator is green when the level is below the indicator. It turns red if the level rises above the indicator to warn the tank is full and about to overflow

FEATURES

- NON-ELECTRIC OPERATION
- FLOW AND LEVEL MODELS AVAILABLE
- BRIGHT RED AND GREEN INDICATION
- CORROSION RESISTANT CONSTRUCTION
- SHATTER PROOF SUPER TOUGH WINDOW
- SUITABLE FOR AIR AND GAS APPLICATIONS
- NON-METAL POLYPROPYLENE MODELS
- STAINLESS STEEL MODELS AVAILABLE
- 1" BSP OR 1"NPT PROCESS CONNECTION
- DIESELINE MODELS AVAILABLE
- USE IN COLOURED LIQUIDS
- CAN BE USED IN SEAWATER
- FULLY WEATHERPROOF

FLOW DIRECTION

The V25F flow indicator can be mounted in pipe running either vertically or horizontally. Please note however, the indicator is not suitable for use in vertically running pipe where flow is moving in a downward direction.

SENSITIVITY

The flow required to actuate the V25F flow indicator will depend on several variables. These include orientation of the indicator, liquid viscosity and the exact area of paddle face exposed to the flow. Generally, the paddle should extend to the centre line of the pipe, or a little past the centre. For high flows the paddle should be cut shorter and for low flows it should be left longer. If the flow rate is known, a reasonably accurate estimate of the correct paddle length can be obtained online by using our flow calculator at: - www.kelco.com.au

MODEL V25L

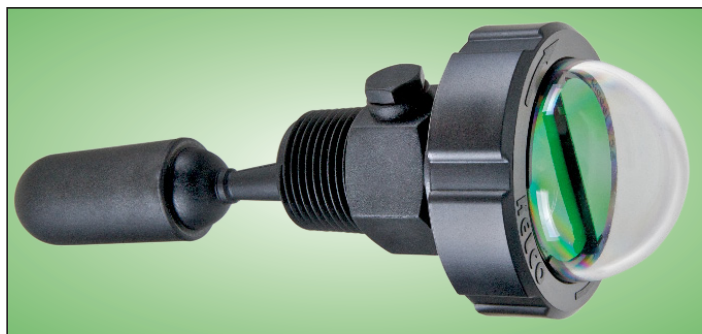

The V25 is a non-electrical insertion style inferential visual indicator that can be used to monitor flow in pipe systems or liquid level in tanks and vessels.

TECHNICAL INFORMATION

DIMENSIONS

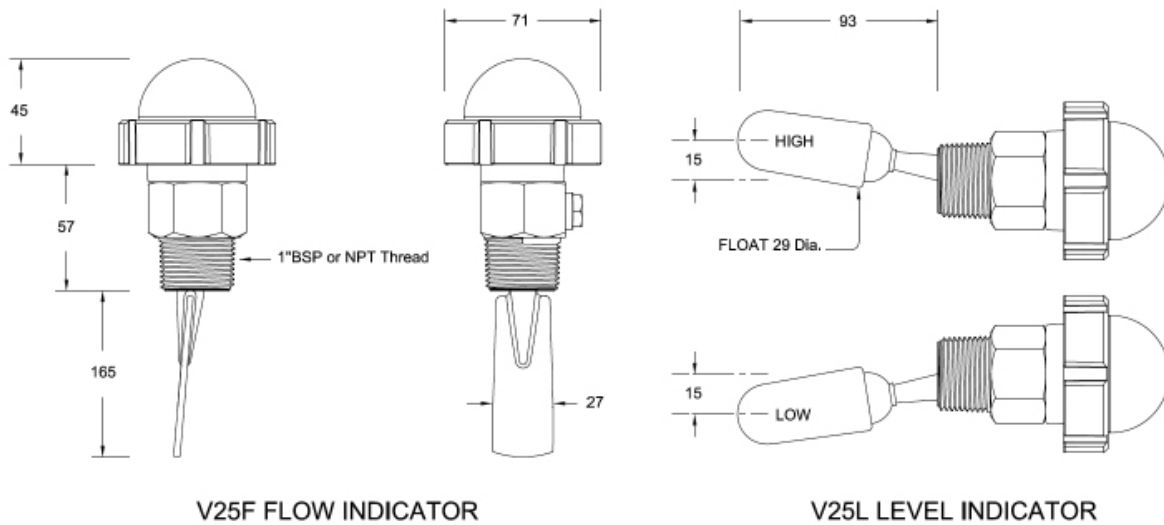

OPERATING LIMITATIONS

Model	V25F-PP	V25F-SS	All V25L Models
Maximum operating pressure (Static or Dynamic at ambient temperature)	10 Bars (150 PSI)	200 Bars (2880 PSI)	200 Kpa (30 PSI) 20 meters submergence
Minimum burst pressure at ambient temperature	40 Bars (600 PSI)	500 Bars (7200 PSI)	350 Kpa (50 PSI) 35 meters submergence
Maximum operating temperature	60°C See note below	70°C	60°C See note below
Minimum operating temperature	0°C	0°C	0°C
Minimum liquid S.G.	0.8	0.8	0.8
Ingress protection rating	IP68	IP68	IP68

PLEASE NOTE: Maximum operating pressure for the all Polypropylene V25 flow indicators must be linearly de-rated as operating temperature is increased. At a process liquid or gas temperature of 60°C the maximum permissible operating pressure for the all Polypropylene indicators must not exceed one Bar (14.7psi) absolute.

ORDER CODE

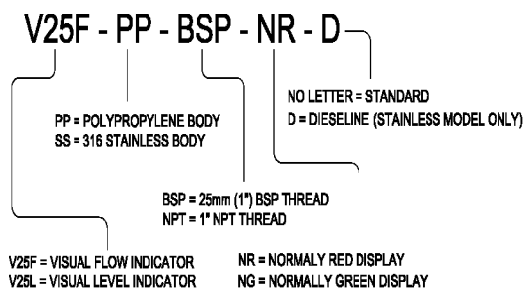

GENERAL INFORMATION

SPARE PARTS

Spare paddles and float arms are available from the manufacturer to suit all V25 indicators.

HAZARDOUS APPLICATIONS

The V25 visual indicators are non-electric and can be used in hazardous Ex applications. They contain no materials or components capable of generating or retaining an electric charge.

WARRANTY

The Kelco V25 indicators are protected by a 12 month return to base warranty. Full details of our warranty can be downloaded from: <http://www.kelco.com.au/menu/information/warranty-statement/>

Supplied to you
by



V25 VISUAL INDICATOR INSTALLATION INSTRUCTIONS

PLEASE READ THIS INSTALLATION SHEET CAREFULLY AND FULLY BEFORE INSTALLING THIS VISUAL INDICATOR

INTRODUCTION

The V25 visual indicator is a unique magnetically operated device that gives a bright red or green indication of flow or liquid level. The basic indicator is available in two forms, one for flow monitoring and one for liquid level monitoring. The flow indicator is designated V25F and the level indicator V25L. In addition, the basic indicator is available with a 1"BSPT or a 1"NPT process connection. It is also available with a wet end pressure housing made from 316 stainless steel or polypropylene. The model number of the indicator is located on the packaging. Details of the various models and their environmental limitations are given in the table below.

PLEASE NOTE: The clear dome on top of the indicator is sealed and is not removable. Do not attempt to rotate the dome or its castellated locking ring as to do so may damage the indicator.

MODEL	V25F-PP	V25F-SS	ALL V25L MODELS
Maximum operating pressure (static or dynamic at ambient temperature)	10 Bars (150 PSI)	200 Bars (2880 PSI)	200 Kpa (29 PSI) 20 metres submergence
Minimum burst pressure at ambient temperature	40 Bars (600 PSI)	500 Bars (7200 PSI)	350 Kpa (50 PSI) 35 metres Submergence
Maximum operating temperature	60°C See note below	70°C	60°C See note below
Minimum operating temperature	0°C	0°C	0°C
Minimum liquid SG	0.8	0.8	0.8
Ingress protection rating	IP68	IP68	IP68

PLEASE NOTE: Maximum operating pressure for all Polypropylene V25F flow indicators and V25L level indicators must be linearly de-rated as operating temperature is increased. At a process liquid or gas temperature of 60°C the maximum permissible operating pressure for the all Polypropylene V25F indicators and all models of the V25L indicators must not exceed one Bar (14.7 psi) absolute.

V25F FLOW INDICATORS

The V25F flow indicator is available with either a normally red (NR) face or a normally green (NG) face. The Normally red indicator will suit most applications, as it displays red when flow has stopped and green when flow is present. The normally green indicator is the reverse of the normally red indicator. It displays green when there is no flow and red when flow is present. Its applications include indicating red for danger or warning when flow is present. An example of its use would be to indicate discharge from a pressure relief valve or overflow line.

The V25F flow indicator can be used in coloured, cloudy or turbid liquids or gases. It can also be used in liquids containing solids, and when fitted with a suitable trailing wire sensor, can also be used in effluent and sewage applications.

The V25F flow indicator is available in a number of materials and configurations to suit specific applications. Please ensure the flow indicator is only used in applications that are within the pressure and temperature range of the specific model.

FLOW SENSITIVITY

The flow required to actuate the V25F flow indicator will depend on several variables. These include orientation of the indicator, liquid viscosity and the exact area of paddle face exposed to the flow. Generally the paddle should extend to the centre line of the pipe, or a little past the centre. For high flows the paddle should be cut shorter and for low flows it should be left longer. If the flow rate is known, a reasonably accurate estimate of the flow required to actuate the V25F can be obtained online by using our flow calculator at: - www.kelco.com.au

INSTALLING THE V25F FLOW INDICATOR

Select a suitable location for the flow indicator. The indicator should be installed in a straight section of pipe with at least 5 diameters of straight pipe either side of the indicator. A 25mm (1") BSP or 1" NPT socket is required to fit the indicator. The pipe socket can be welded to the pipework, or the indicator can simply be screwed into a suitable pipe tee or tapping saddle. The socket or tee needs a full 27mm clearance hole through into the main pipe to facilitate fitting the indicator paddle. Cut the paddle of the flow indicator to suit the specific application (see section on flow sensitivity). Use Teflon tape or pipe sealing compound and screw the flow indicator into the pipe socket or pipe tee. **Do not screw the indicator in by using its castellated locking ring.** Always use a suitable spanner and the spanner flats provided. Leave at least 4mm of the top of the 25mm thread exposed and do not bottom the thread out in the socket. Align the flow direction arrows on the top face of the flow indicator with the direction of flow. This alignment is important and the paddle face must be square and at right angles to the line of flow to operate properly.

The V25F flow indicator can be installed in horizontal pipework or in vertical pipework, provided the flow is upward. Please note this indicator is not suitable for use in vertically running pipework where the direction of flow is downward. Do not mount the indicator on the underside of horizontal pipework, as foreign matter in the process media may accumulate in the body of the indicator and prevent it from operating correctly.

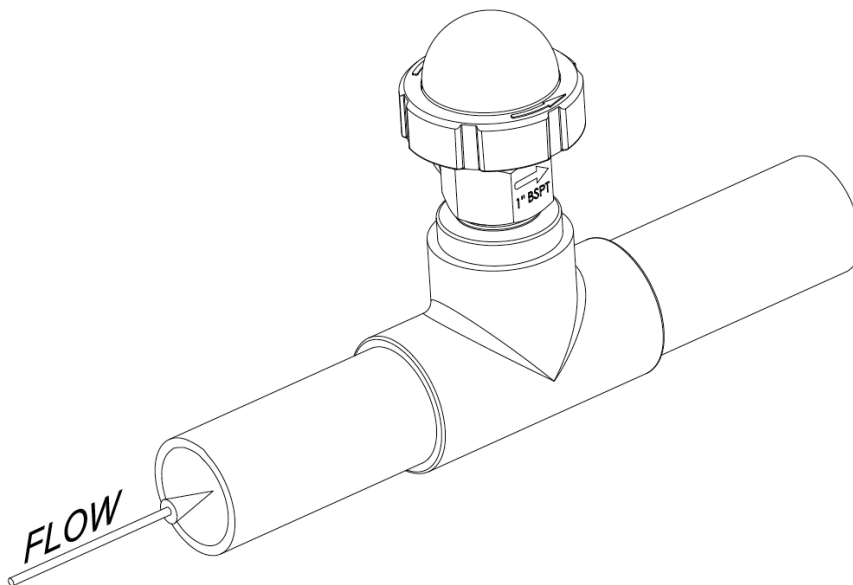

PANEL MOUNTING

The V25F flow indicator can be mounted through a panel fascia or cowling if required. To do so simply drill a 50mm diameter hole through the panel and insert the flow indicator through the hole. Marry up the pipework to the indicator behind the panel face so the underside face of the castellated locking ring on the indicator body finishes flush against the front face of the panel.

END VIEW OF TYPICAL V25F INSTALLATION

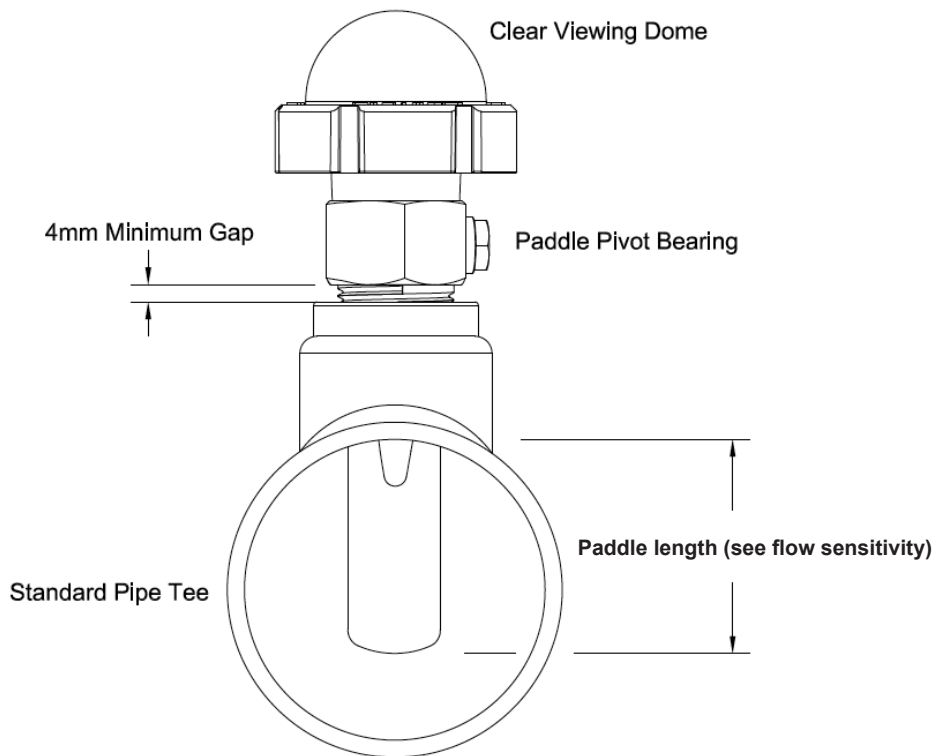

END VIEW OF TYPICAL INSTALLATION

V25L LEVEL INDICATOR

The V25L level indicator is available with either a normally green (NG) or a normally red (NR) face. The colour of the face of the indicator must be chosen when ordering to suit the intended application. As an example, for a low level indicator the V25L would be ordered as NR, (normally red). When the liquid level is above the indicator, the face of the NR indicator will be green, and change to red if the level drops below the indicator. For a high-level warning application, the V25L should be ordered as NG (normally green). The face of this indicator is green when the level is below the indicator, but turns red if the level rises above the indicator. The V25L requires <30mm of liquid level change to turn its face from red to green or from green back to red.

The V25L level indicator is suitable for use in solids free liquids only. It can be used in coloured, turbid or brackish liquids, but should not be used in liquids containing solids or in liquids that cake out or coat surfaces. Solid materials of any kind can accumulate in the body of the indicator and may prevent its correct operation.

The V25L level indicator is suitable for mounting in a 1" tank socket on the side wall of a tank. It requires a 29mm diameter clearance hole to fit the float arm through. The indicator should be installed at a critical position on the tank wall, for example, just above the low level point close to the base of a tank, or just below the overflow level at the top of the tank.

Using Teflon tape or thread sealant screw the indicator into its socket using the spanner flats provided. **Do not screw the indicator in by using its castellated locking ring**, always use a suitable spanner and the spanner flats provided. Leave a 4mm gap between the tank socket and the top of the thread on the V25L indicator. Align the indicator squarely so its flag axis is exactly horizontal and its float arm is free to move vertically up and down through its full range of travel.

V25L TYPICAL TANK INSTALLATION

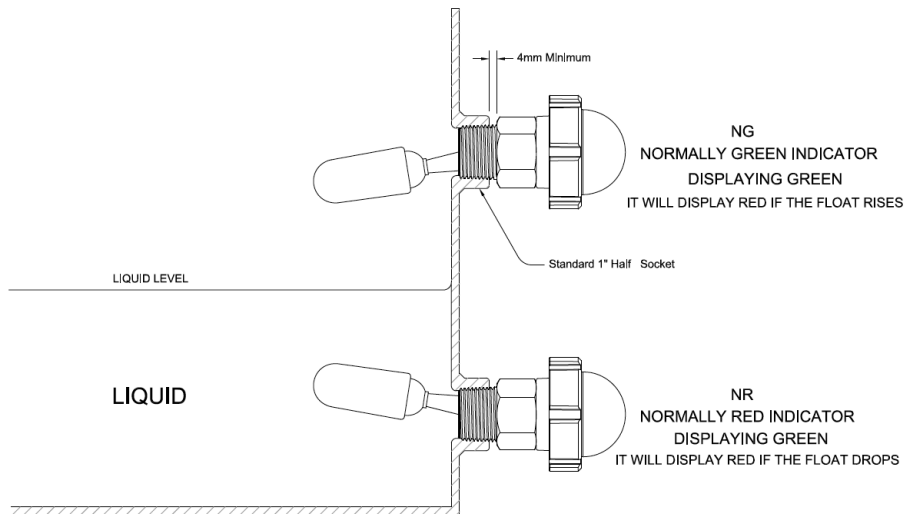

V25L TYPICAL TANK INSTALLATION

MODELS AVAILABLE

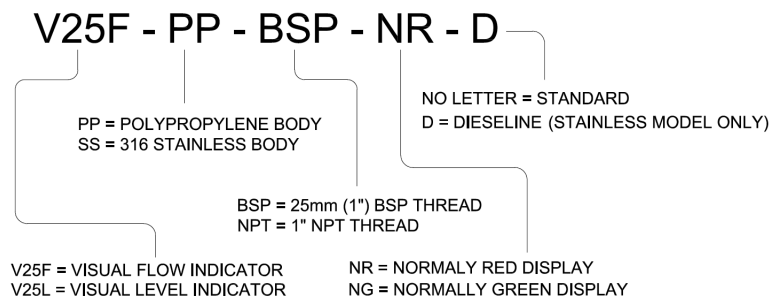

Please Note: Dieseline indicators are only available with stainless bodies, not with Polypropylene bodies.

HAZARDOUS APPLICATIONS

The V25 indicator is suitable for use in hazardous applications as it is a non-electric indicator that contains no components capable of generating or retaining an electric charge.

SPARE PARTS

Spare paddles and float arms are available from the manufacturer to suit all V25 indicators.

WARRANTY

The Kelco V25 visual indicator is protected by a 12 month return to base warranty. Full details of our warranty can be downloaded from: <http://www.kelco.com.au/menu/information/warranty-statement/>

Supplied to you
by

