

PT16 PRESSURE TRANSMITTER

4 to 20mA at 0 to 16 Bars (0 to 230 psi)



AUSTRALIAN MADE

APPLICATIONS

- CONTROL OF VARIABLE SPEED DRIVES
- GENERAL PROCESS CONTROL

FEATURES

- HIGH ACCURACY
- 4 to 20 mA OUTPUT
- WIDE TEMPERATURE RANGE
- PRECISION CERAMIC PRESSURE TRANSDUCER
- STAINLESS AND POLYPROPYLENE CONSTRUCTION
- SUITABLE FOR SEA WATER USE
- TOUGH RELIABLE CONSTRUCTION
- WEATHERPROOF HOUSING IP67

The PT16 pressure transmitter is a rugged solid-state device that will generate an accurate 4 to 20mA signal when installed in an instrumentation loop. It will provide a linear signal across its full pressure range at loop voltages from 12V to 36V DC. It is ideal for use with variable speed drive pumps.

INTRODUCTION

When installed in an instrumentation loop, the PT16 pressure transmitter will provide a linear 4 to 20mA signal that is directly proportional to the applied gauge pressure. The PT16 pressure transmitter is suitable for use in loop circuits operating at 12 to 36V DC.

CONSTRUCTION

The PT16 pressure transmitter is corrosion resistant. It is constructed from high impact glass reinforced polypropylene, ceramic and 316 stainless steel. It is ideal for use in potable water; aggressive bore water, seawater and a huge variety of chemical solutions including most acids and alkalis.

TECHNICAL DATA

PROTECTION

Reverse polarity protected	Yes, bi-directional loop connection
RF protected	Yes, RF protection built in
Earthed	Yes, earth terminal provided
Over voltage protected	Yes, up to 60V DC
Calibration	Factory calibrated

OPERATING ENVIRONMENT

Ambient Temperature Range	1°C to 50°C
Liquid Temperature Range	1°C to 60°C, See note below
Ingress Protection Rating	IP67
Loop Supply	12 to 36V DC
Maximum Operating Pressure	16 Bars (230 psi)

DIMENSIONS

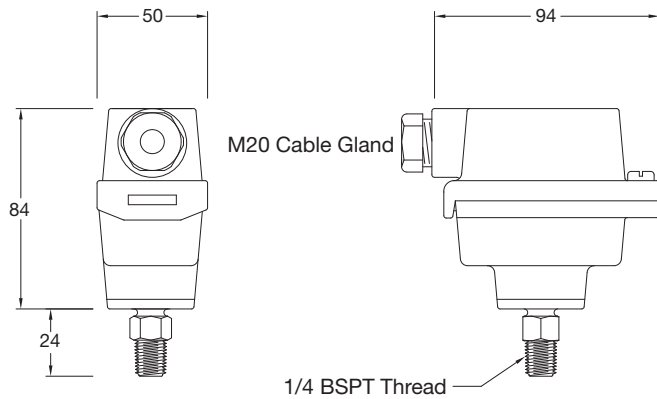

OPERATING RANGE

Accuracy	+/- 0.10% Full Scale at 0 to 60°C
Temperature range, ambient	0 to 50°C
Liquid temperature range	0 to 60°C
Pressure range	0 to 16 Bars (0 to 230 psi)
Burst pressure	32 Bars (460 psi) minimum

NOTE in the interests of safety the PT16 pressure transmitter must NOT be used in hot water applications (>60°C).

The PT16 pressure transmitter is designed to operate at pressures up to 16 Bars (230 psi) and must not be used in applications where either the static or dynamic pressure exceeds this rating.

BASIC LOOP CIRCUIT

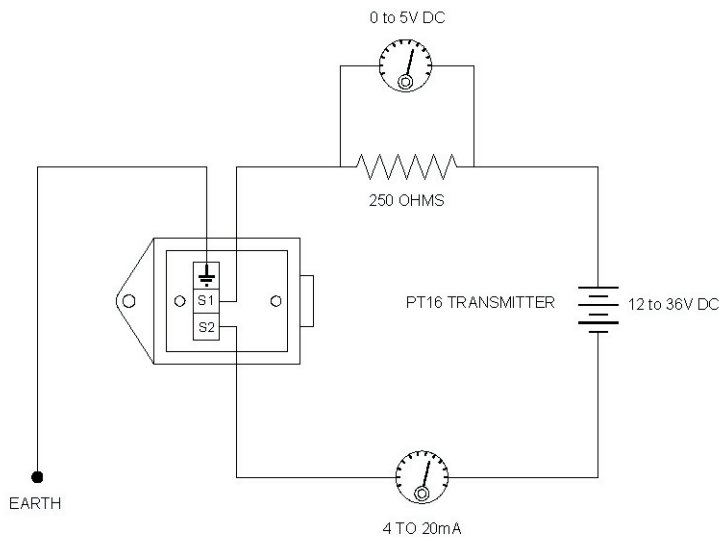

WARRANTY

The Kelco PT16 pressure transmitter is protected by a 12 months return to base warranty. Full details of our warranty can be downloaded from:- <http://www.kelco.com.au/menu/information/warranty-statement/>

MADE IN AUSTRALIA BY

Supplied to you
by

**Power
Control** 
PRODUCTS

PLEASE NOTE: Kelco Engineering Pty Ltd reserves the right to change the specification of this product without notice. Kelco Engineering Pty Ltd accepts no liability for personal injury or economic loss as a consequence of the use of this product. All rights reserved copyright Kelco Engineering Pty Ltd © 2010

INSTALLING AND USING THE KELCO PT16 PRESSURE TRANSMITTER

INTRODUCTION

The PT16 pressure transmitter is a solid-state two-wire device that converts an applied pressure to an analogue 4 to 20mA current signal. Its main use is for the control of variable speed drives and for remote monitoring of pressure in process control applications

CONSTRUCTION

The PT16 pressure transmitter is made from glass reinforced Polypropylene with a ¼" BSP male 316 stainless steel process connection. The pressure transducer built into the PT16 is a one-piece ceramic sensing element.

APPLICATIONS

The PT16 pressure transmitter is suitable for use in water, seawater and the majority of water-based solutions including most mild acids and alkalis. It should not be used in liquids >60°C or < 1°C.

INSTALLATION

Install the PT16 pressure transmitter in a location that is protected from the weather and mechanical damage, out of direct sunlight and in a section of pipe that is of a uniform diameter. Do not install the pressure transmitter on pipe bends or adjacent to valves or pipe reducers. The PT16 pressure transmitter will provide a signal that is a true representation of the system pressure at the exact location it is installed. System pressure is a dynamic parameter likely to vary from place to place in any particular installation. The static pressure at any given point in a system is a function of the velocity of the liquid movement and the geometry of the pipe cross section at the site of the installation. To generate a signal that is a true representation of the average systems pressure, install the PT16 pressure transmitter in a location where the pipework is of a uniform diameter and straight.

A ¼" BSP female port is required to fit the PT16. The transmitter can be directly screwed into the process pipework or it can be remotely mounted and connected into the system using tubing.

PROTECTION

Reverse polarity protected	Yes, bi-directional loop connection
RF protected	Yes, RF protection built in
Earthed	Yes, earth terminal provided.
Over voltage protected	Yes, up to 60V DC
Calibration	Factory calibrated

OPERATING ENVIRONMENT

Ambient Temperature Range	1° C to 50° C
Liquid Temperature Range	1° C to 60° C, See note below
Ingress Protection Rating	IP67
Loop Supply	12 to 36V DC
Maximum Operating Pressure	16 Bars (230 psi)

OPERATING RANGE

Accuracy	+/- 0.10% Full Scale at 0 to 60° C
Temperature Range at ambient temperature	0 to 50° C
Liquid Temperature Range	0 to 60° C
Pressure Range	0 to 16 Bars (0 to 230 PSI)
Burst Pressure	32 Bars (460 PSI) Minimum

NOTE: In the interests of safety the PT16 pressure transmitter must NOT be used in hot water applications (>60°C). The PT16 pressure transmitter is designed to operate at pressures up to 16 Bars (230 psi), and must not be used in applications where either the static or dynamic pressure exceeds this rating.

ELECTRICAL

The PT16 pressure transmitter should be connected into a 12 to 36V DC instrumentation loop circuit using shielded two-core cable. The transmitter is provided with an earth terminal and the cable shielding should be connected to this terminal. The PT16 transmitter is a bi-directional device so loop wires of either polarity can be connected into terminals S1 and S2 on the transmitter with no regard to their polarity. A basic circuit schematic for a simple instrumentation loop circuit is shown below. A DC power supply of 12 to 36 volts is fed through a current limiting 250-Ohms resistor to the PT16 transmitter. A Milliamp meter placed in series in the circuit will read 4mA when the transmitter is exposed to atmospheric pressure. If pressure is applied at the process connection on the PT16, the current signal will increase until it reads a maximum of 20mA at an applied pressure of 16 Bars gauge. If a 0 to 5V signal is required it can be derived from the loop circuit by measuring the voltage drop across the 250-Ohms resistor as shown in the sketch.

CALIBRATION

The PT16 pressure transmitter is factory calibrated to give a 4 to 20mA signal across a 0 to 16 Bar (gauge) pressure range. In most applications post configuring the signal will be possible to align the transmitter with the requirements of the system. Where this is not the case, the PT16 transmitter can be ordered from the factory calibrated to cover whatever pressure range is required within the capacity of the sensor.

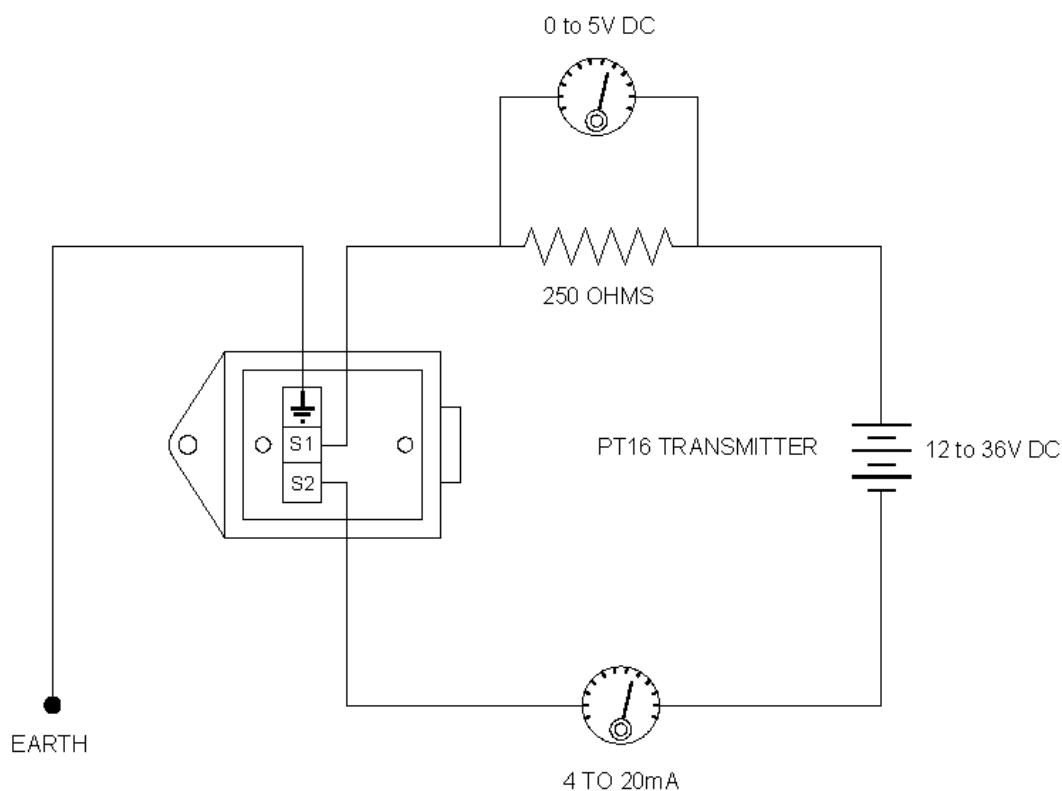

BASIC LOOP CIRCUIT

Made in Australia by

Supplied to you
by

**Power
Control**
PRODUCTS 