

F40 DIGITAL PUMP CONTROLLER

FOR ALL PIPE SIZES 25mm (1") AND LARGER



APPLICATIONS

- DOMESTIC WATER SUPPLY
- INDUSTRIAL PUMP CONTROL
- CONTROL OF TRANSFER PUMPS
- IRRIGATION PUMP CONTROL
- PRESSURE BOOSTING PUMPS
- WATER TREATMENT SYSTEMS
- WASHDOWN CONTROL
- POOL & SPA PUMPS
- BORE PUMP CONTROL

FEATURES

- ELIMINATES PRESSURE TANKS AND SWITCHES
- NO METAL PARTS IN CONTACT WITH WATER
- STARTS ON PRESSURE STOPS ON FLOW
- SUITS ALL PIPE SIZES 25mm (1") & LARGER
- HIGHLY ADAPTABLE & ADJUSTABLE
- AUTO RESTART AFTER RUNNING DRY
- DIRECTLY CONTROL PUMPS TO 3.75kW
- IGNORES MINOR FLOW FLUCTUATIONS
- INDICATOR LIGHTS FOR ALL FUNCTIONS
- SUITABLE FOR USE IN SEAWATER
- TOUGH RELIABLE CONSTRUCTION
- 20 BAR (300 psi) PRESSURE RATING
- WEATHERPROOF HOUSING IP67
- SIMPLE PLUG IN INSTALLATION

INTRODUCTION

The F40 Digital Pump Controller is a powerful self-contained microcomputer that controls and protects a pump under its command. The F40 provides a seamless environment for the pump and gives the end user all the advantages of constant flow and at the same time protects the pump against damage from being run dry. Constant flow means a smooth supply free from the pressure fluctuations that plague conventional pressure controlled pumps.

THE BASIC PROBLEM

Pressure systems cycle between low and high pressure. Not because this gives the user any advantage but simply because a pressure differential is required to operate the pressure switch that normally controls such systems. The user sees the effect as annoying pressure fluctuations at the tap. If run dry for any reason, such a pressure system will run continuously and generally sustain serious damage because it has no means to sense the lack of water and shut down.

THE F40 SOLUTION

The F40 Digital Pump Controller monitors both flow and pressure and only allows the pump to run if water is present. In a typical application the pump will start when there is a demand for flow or when the pressure falls. When demand ceases the controller continues to run the pump for a settable time that is sufficient to re-pressurise the system. The pump will then automatically shut down. Such a system allows the selection of a pump that has an essentially flat pressure and flow curve and delivers a steady constant pressure over widely varying flows. An air cell is not needed in the system but can be included to reduce the frequency of pump starts. With the F40 controller the start-up pressure is set to start the pump at a pressure only marginally higher than the system's static pressure. If the demand is too low to actuate the F40's flow sensor, or if for any reason the pressure falls, the F40's built in pressure sensor will detect the pressure fall, automatically run the pump, re-pressurise the system, then shut down the pump and go back to monitoring the whole system.

DRY RUN PROTECTION

A pump under the control of an F40 will start if the pressure drops, or on flow if a tap is turned on. If the system runs out of water the F40 senses the loss of flow and the lack of pressure and stops the pump. A red warning light on the F40 then flashes rapidly to indicate there is a problem. The F40 can be set to simply remain in alarm mode until attended to, or to wait for a settable time and then attempt to restart the whole system.

AUTOMATIC RESTART FEATURE

The digitally controlled restart feature on the F40 is ideal for pumping from low yield bores. Under the control of an F40 a bore pump can be automatically cycled. It can be pumped until dry and then left for a settable time for the standing water level to recover. The whole process can then be repeated endlessly. Using this method a low yield bore can be pumped to its maximum capacity. The F40 can be set to automatically restart the pump from 1 minute to 48 hours after being run dry.

CONSTRUCTION

The F40 digital pump controller is made from high compliance thermoplastic and has no metal parts in contact with water. It operates magnetically through a seal-less coupling system. It is ideal for use in potable drinking water, aggressive bore water, seawater and a huge variety of chemical solutions.



AUSTRALIAN MADE

TECHNICAL DATA

DIMENSIONS

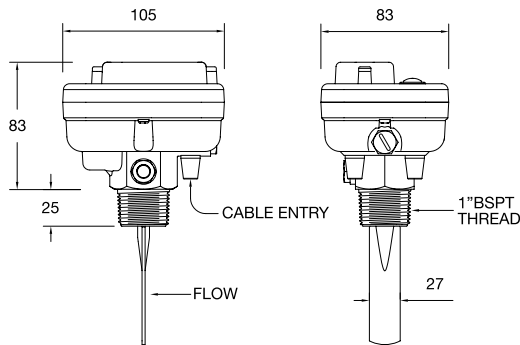

ORDERING

The F40 Digital Pump Controller is available in a number of configurations to suit specific applications. For directly controlling pumps up to 2.4kW (3HP) It can be supplied as 'Plug & Play' with 10Amp leads and fitted with a plug and socket. For large fixed installations It can also be supplied in a heavy duty form fitted with 2 metre long 15A cables, or fitted with a single 2 metre long cable that has either 4 or 5 cores for either direct control of pump motors to 2.4kW (3HP) (4 core version), or with 5 core cable for use in single and 3-phase control circuit applications. In addition there is a universal low voltage AC/DC model available. The part numbering system below sets out how to order a specific configuration.

The standard F40 has a startup pressure range of 0 to 10 Bars. High start up pressure models are available that have a start up pressure range of 0 to 20 Bars (0 to 300 psi). To order controllers with this option simply add "HP" to the end of the part number.

F40 - 240 - S - 5

SUPPLY VOLTAGE
240 = 220 TO 240VAC
24 = 24V AC or DC

CABLE CORES
4 = 4 CORE 10Amp CABLE
5 = 5 CORE 6Amp CABLE

CABLE

NO LETTER = 10Amp PLUG & PLAY
HD = HEAVY DUTY 15Amp CABLES 2 X 2M LONG
S = SINGLE CABLE 2M LONG WITH 4 or 5 CORES

Please Note: The universal 24V AC/DC model is only available in F40-24-S-5 configuration, that is, with a single 5-core cable for control circuit applications only.

OPERATING ENVIRONMENT

Supply F40-240	220 to 250VAC 50Hz Single Phase
Supply F40-24	12 to 28 Volts AC or DC at 80mA Max.
Ambient Temperature Range	1°C to 50°C
Liquid Temperature Range	1°C to 60°C
Ingress Protection Rating	IP67

WARRANTY

The Kelco F40 Digital Pump Controller is protected by a 12 months return to base warranty. Full details of our warranty can be downloaded from: - <http://www.kelco.com.au/menu/information/warranty-statement/>

OPERATING RANGE

Start-up Timer	Adjustable from 1sec. to 3 minutes in 15 steps
Run-on Timer	Adjustable from 1 sec. to 5 minutes in 15 steps
Restart Timer	Adjustable from 1 minute to 48 hours in 15 steps
Pump Start Pressure Range	0 to 10 Bars (0 to 150 psi) in 16 steps, See note below
Maximum Starting Pressure	1000kPa (150 psi)
Minimum Starting Pressure	50kPa (7 psi)
Recommended Pipe Sizes	25mm (1") or larger. (There is no upper limit)
Maximum Switched Load F40-240	250VAC 50Hz 2.4kW (Motors up to 3HP)
Maximum Switched Load F40-240-HD	250VAC 50Hz 3.75kW (Motors up to 5HP)
Maximum Switched Load F40-240-S-4	250VAC 50Hz 2.4kW (Motors up to 3HP)
Maximum Switched Load F40-240-S-5	250VAC 50Hz 6Amps Non Inductive
Maximum Switched Load F40-24-S-5	250VAC 50Hz 6Amps Non Inductive
Operating Pressure Range, Static or Dynamic	0 to 20 Bars (0 to 300psi) See Note Below
Burst Pressure	50 Bars (750 psi)

NOTE: A high starting pressure model is available with a start up range of 0 to 20 Bars (0 to 300 psi), add "HP" to the part number for this option.

NOTE: The F40 pump controller must NOT be used in hot water applications (>60°C). The F40 pump controller is rated to withstand water pressure to 20 Bars (300 psi) and must not be used in applications where the static or dynamic pressure exceeds this rating.

TYPICAL PUMP INSTALLATION

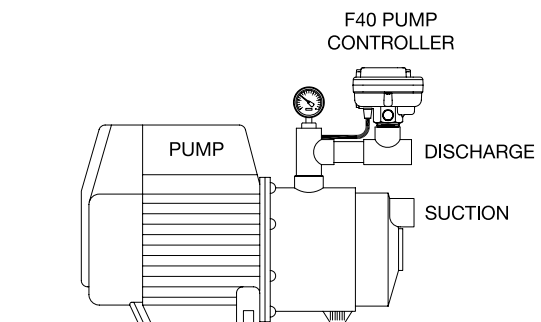

SPARE PARTS

Spare Paddles are available for the F40 Digital Pump Controller.

STANDARDS

The F40 Digital Pump Controller is certified to Australian Standards: -
AS60529-2004
AS61010.1: 2003
AS/NZS CISPR 14.1:2003

Supplied to you
by

**Power
Control**
PRODUCTS

PLEASE NOTE: The Kelco F40 Digital Pump Controller is the subject of Australian and International patent and trademark applications.

Kelco Engineering Pty Ltd reserves the right to change the specification of this product without notice. Kelco Engineering Pty Ltd accepts no liability for personal injury or economic loss as a consequence of the use of this product. All rights reserved copyright Kelco Engineering Pty Ltd © 2010

) .34! , ,) . ' ! . \$ 53) . ' 4 (% + % , # / & \$) ') 4 ! , 05-0 # / . 42 / , , % 2

7!2.) . ') . 42 / \$ 5 # 4) / .

10% 2!4) . ' 2! . ' % ! , , - / \$ % , 3

PLEASE READ THIS INSTALLATION SHEET FULLY AND CAREFULLY. THE DIGITAL PUMP CONTROLLER IS A MAINS VOLTAGE DEVICE. DEATH OR SERIOUS INJURY MAY RESULT IF THIS PRODUCT IS NOT CORRECTLY INSTALLED AND USED.

) . 42 / \$ 5 # 4) / .

THE PUMP CONTROLLER IS A MICROPROCESSOR-BASED INTEGRATED PRESSURE AND FLOW DEVICE. IT IS DESIGNED FOR CONTROLLING THE OPERATION OF A PUMP AND FOR PROTECTING AGAINST RUNNING DRY.

THE PUMP CONTROLLER CAN BE USED IN A VARIETY OF SITUATIONS TO CONTROL AND SAFEGUARD A PUMP. SOME MODELS CAN DIRECTLY CONTROL SINGLE PHASE PUMP MOTORS UP TO (0 WITHOUT THE NEED FOR AN INTERPOSING CONTACTOR. IN ADDITION TO PROTECTING THE PUMP FROM DRY RUN DAMAGE THE CONTROLLER CAN BE SET TO AUTOMATICALLY MAINTAIN LINE PRESSURE IN STOCK WATERING APPLICATIONS OR FOR CYCLICALLY PUMPING LOW YIELD STOCK DOMESTIC BORES.

D

7!2.) . ') . 34! , , ! 4) / .

THE DIGITAL PUMP CONTROLLER IS WATER RESISTANT TO 1 BAR AT THIS RATING. ONLY APPLIES IF THE CLEAR CONTROL SCREWS FULLY TIGHTENED. THE CONTROLLER IS NOT WATER RESISTANT UNLESS THE CLEAR LID IS IN PLACE AND FULLY SECURED. ALWAYS REPLACE THE CLEAR LID AND FULLY TIGHTEN ITS TWO SCREWS AFTER MAKING & CHANGING CONTROLLER SETTINGS. THE CONTROLLER MAY PRESENT A SHOCK HAZARD AND BE USED IN APPLICATIONS WHERE THE STATIC RESULT IF WATER ENTERS THE ELECTRICAL HOUSING. THERE ARE NO USER SERVICEABLE PARTS IN THIS PUMP CONTROLLER. SHOULD THE MAIN HOUSING BE OPENED AUTOMATICALLY VOID IF THE SEALED BODIES ARE SUITABLE FOR USE IN ALL COLD WATER SEAWATER BORE WATER CHLORINATED POOL WATER SUITABLE LOCATION SHOULD BE SELECTED FOR PUMP. THE CONTROLLER SHOULD BE INSTALLED AND HEAT PREFERABLY OUT OF DIRECT EXPOSURE TO SUNLIGHT. THE CONTROLLER SHOULD BE LOCATED AT LEAST 150MM FROM ANY OTHER ELECTRICAL EQUIPMENT. THE CONTROLLER SHOULD BE MOUNTED IN AN UPWARD OR DOWNWARD DIRECTION. IN MOST INSTALLATIONS THE PADDLE OF THE PUMP TEE IN WHICH IT IS TO BE INSTALLED SHOULD BE EQUIVALENT TO 100 GRAMS DEAD WEIGHT ACTING CORRECTLY. THE FORCE IS GENERATED BY WATER AREA OF THE PADDLE. THE MORE AREA OF PADDLE AVAILABLE TO ACTUATE THE CONTROLLER THE MORE FORCES AND MAY DAMAGE THE PADDLE. THE PADDLE SHOULD EXTEND TO SLIGHTLY PAST THE CENTRE LINE OF THE PIPE. IT SHOULD BE LEFT LONGER THAN THIS UNLESS THE EXPECTED FLOW RATE AND THE PIPE SIZE OF YOUR APPLICATION IS AVAILABLE AT WWW.KELCO.COM.AU THAT WILL BE THE PADDLE SIZE. USE TIN SNIPS SIDE CUTTERS OR AWAY THE SIDES OF THE PADDLE SO IT CLEARS THE PIPE AT ITS CLOSEST POINT. APPLY A SUITABLE FORCE TO THE PADDLE INTO THE SOCKET USING THE SPANNER. THE CONTROLLER SHOULD BE SQUARE TO THE FACE OF THE PUMP BODY CORRECTLY ORIENTED. THERE SHOULD BE A GAP OF AT LEAST 10MM BETWEEN THE UNDER EDGE OF THE PUMP SPANNER AND THE UNDER EDGE OF THE PIPE SOCKET. THE PUMP SHOULD BE WOUND INTO THE PIPE SOCKET UNTIL IT IS TIGHT. THIS PLACES THE THREAD IN TENSION AND MAY CAUSE DAMAGE UNDER PRESSURE.

) - 0 / 24! . 4

THIS INSTALLATION AND USAGE INFORMATION IS SPECIFIC TO THE MODEL CONTROLLER BEING INSTALLED. THE PRESSURE RATING OF THE CONTROLLERS VARY. PLEASE REFER TO THE USER MANUAL TO UNDERSTAND THE LIMITATIONS OF A SPECIFIC MODEL.

- / \$ % , 3

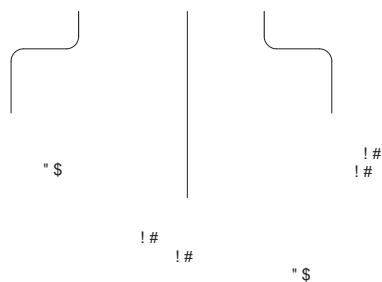

10% 2!4) . ' % . 6) 2 / . - % . 4 ! , , - / \$ % , 3

3 SUPPLY & 3 SUPPLY & AMBIENT TEMPERATURE LIQUID TEMPERATURE (INGRESS PROTECTION) -AXIMUM OPERATING PRESSURE PSI	& , OW 60LTAGE 2# \$ \$ ORD \$ # AT M! -AX	(\$ TO 6!# (Z 3 INGLE 0HASE

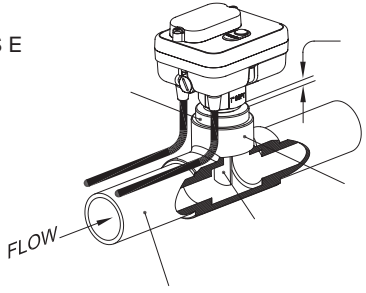

(/ 4 /) . 34! , , ! . & \$) ') 4 ! , 05-0 # / . 4 / , , % 2

ELECTRICAL

The F40 pump controller requires a stable supply voltage in order to operate correctly. Pay particular attention to cable sizes, and ensure cables are adequate for the specific pump motor load. This is particularly important where long cable runs are to be used in the installation. If the voltage drop associated with the starting of the pump motor is excessive the F40 will automatically reset and this may cause the pump to jog. Jogging can snap the main spindle of a pump very easily, so please take all precautions to ensure the voltage supply to the F40 is stable and that the current carrying capacity of the cable is adequate for the job.

Never use long or coiled extension leads (longer than 5 metres) to connect a pump to the F40. The Standard F40-240 pump controller is supplied fitted with a 10 Amp plug and socket. Pumps up to 2.4kW (P1) can be plugged directly into the socket connection to the controller.

NOTE: For mains voltage applications we recommend that the supply to the F40 be isolated by a 10Amp RCD that has a maximum trip current of 30mA.

WARNING

When installing the F40 the socket outlet connection (GPO) for the input power must be accessible, and must be positioned in a dry and protected location out of the weather and above any flood or water level. Where the F40 is to be used to control pump motors up to 2.4kW 3HP the supply to the F40 must be protected by a 10 Amp fuse or by a 10 Amp circuit breaker.

FIXED INSTALLATION

WARNING

Fixed Installations must only ever be carried out by a licensed electrician and must conform to local wiring rules.

The standard F40-240 can directly control single-phase 240V~ 50Hz pump motors up to 2.4kW. When used in a fixed installation a disconnecting device such as a switch or a circuit breaker must isolate the F40. The disconnecting device must be easily and readily accessible after installation. Where a circuit breaker is used it must be rated at 10 Amp. Where an isolation switch is used the circuit must be protected by a 10 Amp fuse. In the interests of safety a 10 Amp RCD with a maximum 30mA trip should also be installed in the supply.

F40-240-HD MODEL ONLY

WARNING

The F40-240-HD is supplied with heavy duty flying leads for fixed installation use only. It must be installed by a licensed electrician and isolated by a 15Amp fuse or a 15Amp circuit breaker. We recommend that the supply to the F40-240-HD be isolated by a 15Amp RCD that has a maximum trip current of 30mA.

BROWNOUT OR BLACKOUT

If a blackout or brownout occurs while the F40 is operating, the controller will not retain any memory of where in its run or stop cycle it may have been, it will simply shut down the pump. When power resumes, the F40 will reboot, restart the pump and run any timer settings from the beginning. A manual reboot can be done at any time by simply pressing the reset button on the top deck of the controller.

ADJUSTING SETTINGS

There are 4 rotary switches located under the clear cover on the top deck of the F40. These 4 dials are for adjusting the timers and pressure switch that control the F40's actions. To access the 4 dials undo the 2 screws that hold the clear cover in place. Note that the clear cover must always be replaced and tightened after making changes to the settings.



WARNING

Without the cover in place the F40 is not water resistant and presents a potential shock hazard. Take great care not to splash water onto the F40 when the control cover is removed and always replace the cover immediately and fully tighten its securing screws after any changes to the settings are made.

After you make any change to the settings on the 4 control dials you must always press the reset button for the changes to take effect.

BASIC WIRING DIAGRAMS

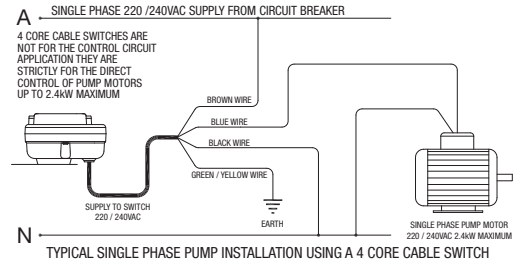
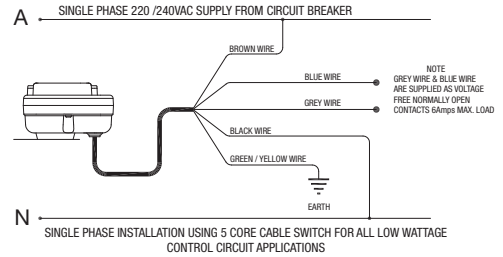

IMPORTANT

4 CORE CABLE SWITCHES ARE NOT SUITABLE FOR CONTROL CIRCUIT APPLICATIONS THEY ARE STRICTLY FOR THE DIRECT CONTROL OF PUMP MOTORS AS SHOWN ABOVE THEY HOUSE A POWERFUL SOLID STATE DRIVE SYSTEM THAT WILL NOT WORK IN LOW WATTAGE CONTROL CIRCUITS

5 CORE CABLE SWITCHES ARE NOT SUITABLE FOR THE DIRECT CONTROL OF PUMP MOTORS THEY ARE FOR THE CONTROL OF CONTACTORS, RELAYS, TIMERS, PLC'S, VS DRIVES AND OTHER LIGHT DUTY CONTROL CIRCUIT APPLICATIONS

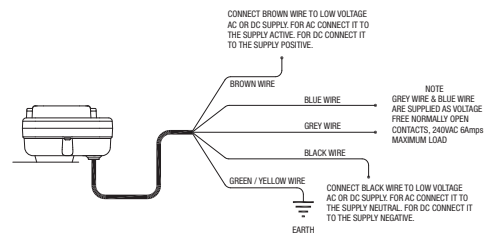
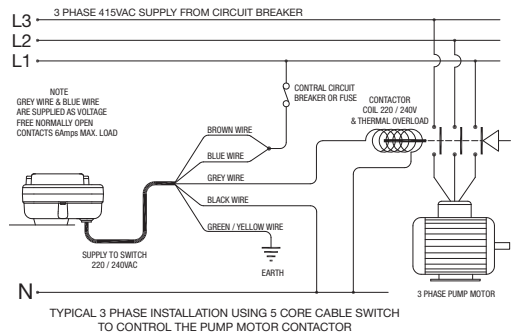

UNIVERSAL LOW VOLTAGE AC / DC SWITCH FOR GENERAL PURPOSE CONTROL CIRCUIT APPLICATIONS

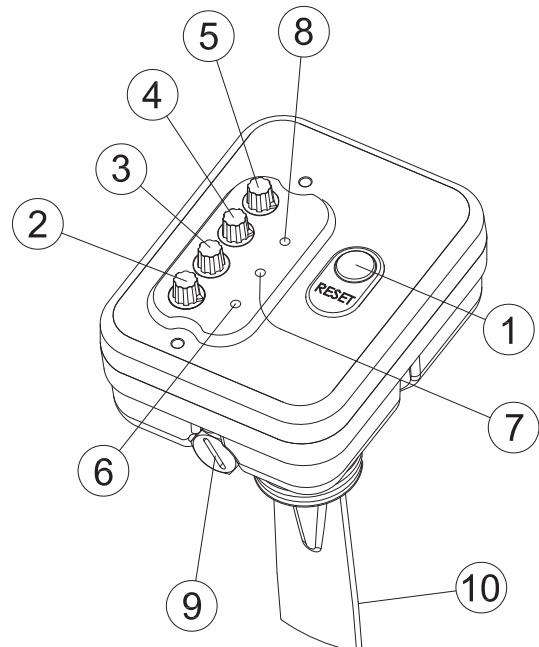

No.	DESCRIPTION	FUNCTION
1	MASTER RESET BUTTON	With power on, press this button to start the pump at any time. Always press it after making any changes to the settings on the 4 timer dials. Any changes you have made will not take effect until you press the reset button. This button can be pressed at any time even if the pump is running. All timers are reset to zero when the reset button is pressed.
2	PRESSURE SETTING	This dial sets the pump's start up pressure. The dial is adjustable from zero to 5 Bars in 16 steps of 33 kPa each. If this dial is left on zero the F40 only senses flow and not pressure. This dial is normally set to marginally higher than the system's static pressure. When pressure falls because a tap has been turned on a point will be reached where the pressure drops to the level set on this dial. The pump then automatically starts and runs for the time set on the run-on dial (4). If there is a demand for flow the pump will run continuously and satisfy the demand.
3	START TIMER	When the F40 is first turned on, or when the reset button is pressed, the start timer sets how long the pump runs for ignoring the fact that there may be no flow or pressure present at that time. The dial can be set from zero to 3 minutes in 16 steps. During this start time the pressure in the system must rise up to a level higher than the pressure set on the pressure dial (2). If the pressure fails to reach the correct level by the end of the timer's run the pump will be automatically shut down. The F40 will then rapidly flash its red alarm light (7). Pressing the reset button (1) re-runs the start timer and adds pressure to the system until the pressure rises above the pressure that is set on the pressure dial (2).
4	RUN-ON TIMER	If the flow is interrupted for any reason while the pump is running this timer sets how long the loss of flow is ignored before the pump automatically shuts down. It can be set from zero to 5 minutes in 16 steps. The run-on timer also determines how long the pump runs for if it is triggered by a pressure drop that reaches the pressure set on the pressure dial (2). It should be set to long enough for the pressure to rise up above the pressure dial (2) set pressure.
5	STOP TIMER	If the F40 goes into alarm mode due to being run dry, this dial sets how long the pump will remain off before the F40 attempts to restart it. This dial is adjustable from zero to 48 hours in 16 steps. If the stop timer is set to zero the pump will not try to restart automatically but if run dry will simply remain in alarm mode, rapidly flashing its red warning light till attended to.
6	START TIMER LED	This light shows steady blue whenever the start-up timer is running. It means the pump is running under the control of the start up timer and the light is letting you know that when the start timer times out the pump will either continue to run, if there is a demand for flow, or automatically shut down and wait for a pressure drop or flow demand to re-trigger it.
7	FLOW STATUS & ALARM LED	This light will show a steady green whenever the paddle of the F40 is held on by flow. It will be on at all times there is a modest flow through the system. This light also pulses slowly red whenever the F40 is powered up and in standby mode. It indicates that everything is OK and the F40 is simply waiting for a flow demand or a pressure drop to re-start the pump. This light also flashes rapidly red in alarm mode if the F40 senses that the pump has run dry. If the stop timer is running this light turns steady red indicating the pump has stopped but will re-start after whatever delay is set on the stop timer dial (5).
8	RUN-ON TIMER LED	This light shows steady red whenever the run-on timer is running. If you have set the run-on timer to say 5 seconds to ignore air bubbles in the pipework then the pump will keep running and this light will come on steady red for 5 seconds every time air passes through the system. This light also shows steady red whenever the system starts up on pressure drop. On a pressure start it must be set to remain on long enough for the pressure to rise above the pressure that is set on the pressure setting dial (2).
9	FLOW SENSITIVITY ADJUSTMENT	Under this dust cap is a screw that sets the sensitivity of the F40 to flow. As supplied, this screw is wound fully in which is its least sensitive position. By winding this screw anti-clockwise (out) the F40 can be set to detect progressively lower flows. In other words become more sensitive and responsive to low flows. The screw should not be wound out beyond where the dust cap can be refitted. The F40 will not operate if this screw is fully removed. Use a wide bladed screwdriver to adjust this screw.
10	PADDLE	The paddle (a replaceable item) must be trimmed to suit the intended application. Normally the paddle is cut so when installed it intrudes to a little past the centre line of the pipe. The more area of paddle exposed to the flow the more responsive the F40 will be. The paddle is normally trimmed with a pair of tin snips or a hacksaw. It can be narrowed down and its end rounded to suit the specific pipe in which it is to be installed. The paddle should always be trimmed so there is a minimum of 4mm clearance to the closest adjacent pipe walls. If you know the likely flow rate and the pipe size of your pump system there is an online calculator available at www.kelco.com.au that will help you to work out an exact size to cut the paddle.

TYPICAL LARGE PUMP SYSTEM CONTROLLED BY AN F40

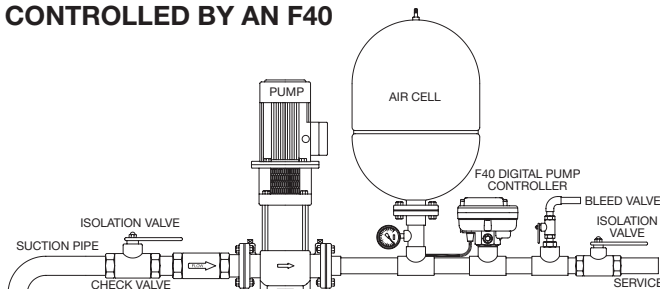

BASIC OPERATION - NO TIMERS USED

With the three timer dials set to zero the F40 pump controller only responds to flow in a basic way. It will behave like a basic on/off flow switch, it will simply turn on and off in direct response to paddle movement. Any pump connected to it will also start and stop in direct response to the actual flow past the paddle of the switch. Power can be switched on to such a system and the pump will not automatically start unless there is initially enough flow past the paddle of the F40 to actually turn it on. This inability to automatically start is the very reason why a timer is normally required to override the off state and start the pump. The only condition under which such a system would automatically start would be if there was flow from some external source, such as from an air cell or a gravity feed from an elevated water source.

START TIMER

Setting the start timer (3) will override the off state of the F40 so that when power is applied, your pump will start and will run for whatever time you have set on the start timer dial. The blue light (6) will be on while the timer is running, and if correctly set, and if there is a flow demand, flow will push the paddle (10) to its on position before the start timer times out. Flow is indicated by the flow status light (7) turning steady green in response to the flow. When correctly set the start timer should run for slightly longer than the time it takes for the water flow to actuate the paddle of the F40 and for the flow status light (7) to come on steady green.

RUN-ON TIMER

The run-on timer can be set to suit the specific application, for example, it can be set to several minutes to pressurise long pipes or a large air cell. It will keep your pump running for up to 5 minutes after the flow has reduced to a point below where the paddle of the F40 can detect. Alternatively, it could also be set to only a few seconds to simply allow the pump to ignore minor fluctuations in flow. The run-on timer only starts when pressure has dropped to whatever pressure you have set on the pressure dial, or the flow has essentially stopped. For example, air passing through the flow switch would normally stop the pump due to the paddle detecting the momentary loss of flow. The run-on timer will keep the pump running seamlessly and ignore this loss of flow for whatever time period it is set to.

The start timer and the run-on timer function independently of each other and are totally flexible. For example you can set the start timer to 3 seconds, to get a pump started, and the run-on timer to 5 minutes to run a pump on and pressurise a pipe system or an air cell. Alternately, you could set the start timer to 3 minutes to allow a bore pump with a self-draining riser time to fill its pipework, and you could also set the run-on timer to 3 seconds to ignore bubbles of entrained gas in the pipe system. Note that the run on period will only commence when the flow has reduced to a lower rate than the F40 is able to detect.

STOP TIMER

The stop timer sets how long the pump remains off once it has been run dry. It can be set on zero or from 1 minute to 48 hours in 15 steps. The stop timer can be set for sufficient time for the standing water level in a bore to recover. At the end of the stop time the pump will automatically restart under the control of the F40. By using the loss of pressure as detected by the F40 when a pump is run dry, a bore pump can be cycled and a low yield bore pumped to its maximum yield. The alarm (7) will turn a steady red whenever the stop timer is running. This is to indicate to you that while the pump is off it will restart automatically at the end of whatever time is set on the stop time dial.

MAINTAINING PRESSURE IN PIPE SYSTEMS

It is often highly desirable to maintain pressure in pipe systems, for example in a stock watering system where long runs of pipe are involved and draw off at the stock troughs is highly variable. Controlling a pressure pump in such systems can be very difficult. A pump under the control of an F40 can be set to start on pressure drop when a remote float valve opens and run while ever there is a flow demand and then automatically stop when the flow demand ceases. The F40 will then monitor the pressure and restart the system whenever the pressure drops again. In such a system air cell pressure or simply line pressure is lost as stock drink. Often this slight drop in pressure is too low to be detected by a normal pressure switch. An F40 can automatically start the pump and run it for however long it takes for the line to pressurise and for the flow to stop. This may take hours or minutes and may vary considerably from time to time. If for any reason flow is lost while the pump is running this will be detected by the F40 and the pump will be shut down. The pump will then attempt to restart and repeat the whole process after waiting for whatever time the stop timer has been set to.

PRESSURE SYSTEMS

The F40 pump controller can be used to protect a conventional pressure start pressure stop pump from running dry if flow is lost. In a conventional pressure system a pressure switch turns the pump on when the pressure drops and switches it off when the pressure rises. All such systems have one basic flaw, if they run out of water for any reason the lack of pressure will hold the pressure switch on and keep the pump running. The result is usually severe damage to the pump. The F40 is an ideal alternative because it monitors flow as well as pressure and will stop the pump from running dry by detecting the loss of flow. The pump will switch on on a falling pressure and switch off when flow ceases.

AIR CELL AND PUMP STARTS

An air cell is not essential in a pump system controlled by an F40.

An air cell can be used in a pump system to store pressure energy and provide the motive power to trigger the system and restart the pump. The F40 relies on either pressure drop or flow to start a pump. If an F40 is installed in a pump system before the air cell, any demand at the tap will be met by the draw off from the air cell until the pressure falls to the level set on the F40's pressure dial. The pump will then start and if there is an on going demand continue to pump. In such a system the draw off capacity of the air cell and the flow demand will determine how frequently the pump starts. A large capacity air cell will reduce the frequency of starting and thus the cycling of the pump. A small draw off air cell will give a more constant pressure but at the expense of more frequent starting.

If the F40 is installed after the air cell, any more than a slight flow from the air cell will start the pump on flow. If the flow demand is extremely low, eventually the pump will simply start on pressure drop once the pressure reaches the pressure dials set point. Where a system is required to supply a constant pressure the F40 should be mounted after the air cell. When pump cycling is to be kept to a minimum, the F40 should be mounted before the air cell and a large draw off capacity air cell should be used in the system.

SENSITIVITY ADJUSTMENT

A sensitivity adjusting screw (9) is provided for fine-tuning the F40. Under the end of the switch housing is a hex-headed plug that covers the adjusting screw. Remove the plug and using a broad-bladed screwdriver wind the adjusting screw anticlockwise to increase the sensitivity (reduce the flow rate needed to actuate the paddle.) As supplied, the screw is wound fully in and the F40 is set to its least sensitive. The maximum sensitivity is reached with the screw wound out to a point where the hex dust cover can still be refitted. Normally the sensitivity screw should be left fully in. If the paddle has been trimmed too short the resultant loss of sensitivity can be offset by winding the sensitivity screw out a few turns.

LIMITATIONS

The mains voltage F40 pump controller requires a stable 220 to 240 V AC 50Hz supply in order to operate properly. Where large pumps are connected to an F40 care should be taken to ensure cable sizes are adequate. Never use the F40 with long or coiled extension leads or on generator sets. The electronics built into the F40 are protected against surges and brownout and these protection systems can be triggered by voltage drop, severe voltage spikes, or by an erratic electrical supply.

The F40 should only be used in ambient temperature water applications. It is neither designed for, nor is it intended to be used with liquids other than water. The F40 pump controller must never be used in hot water applications (greater than 60°C) and must also be protected from freezing.

The standard F40-10 is designed to withstand water pressures up to 20 Bars, (300 psi) and must not be used in applications where either the static or dynamic pressure exceeds this rating.

PLEASE NOTE: The Kelco F40 Digital Pump Controller is the subject of Australian and international patent and trademark applications.

Kelco Engineering Pty Ltd reserves the right to change the specification of this product without notice. Kelco Engineering Pty Ltd accepts no liability for personal injury or economic loss as a consequence of the use of this product. All rights reserved copyright Kelco Engineering Pty Ltd © 2010

A PUMP SYSTEM WITH NO AIR CELL CONTROLLED BY AN F40

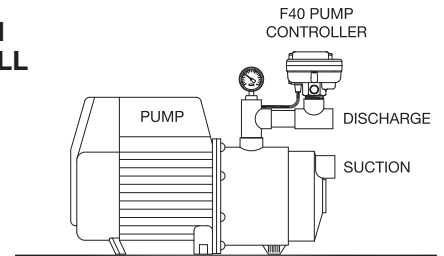

F40 INSTALLED BEFORE THE AIR CELL (SEE TEXT)

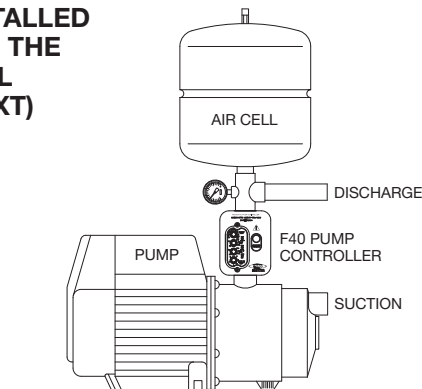

F40 INSTALLED AFTER THE AIR CELL (SEE TEXT)

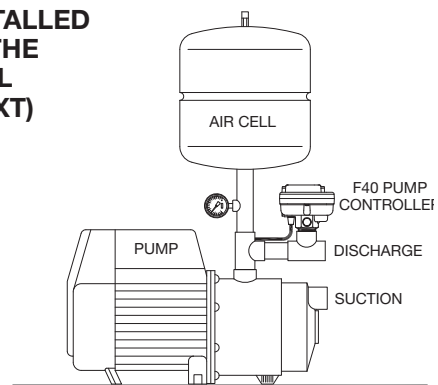

SUBMERSIBLE BORE PUMP CONTROLLED BY AN F40

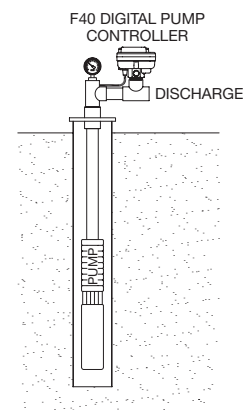

WARNING

If the F40 Pump Controller is used in a manner not specified by the manufacturer the protection provided by the device may be impaired or negated. In addition all warranties stated or implied will be rendered invalid.

Supplied to you
by

Power Control
PRODUCTS

