

F40-240LC PUMP CONTROLLER

SIMPLE BUT POWERFUL
FOR ALL PIPE SIZES 25mm (1") AND LARGER



APPLICATIONS

- DOMESTIC WATER SUPPLY
- INDUSTRIAL PUMP CONTROL
- CONTROL OF TRANSFER PUMPS
- IRRIGATION PUMP CONTROL
- PRESSURE BOOSTING PUMPS
- WATER TREATMENT SYSTEMS
- WASHDOWN CONTROL
- POOL & SPA PUMPS
- BORE PUMP CONTROL

FEATURES

- SIMPLE, ONLY 1 DIAL TO SET
- ELIMINATES PRESSURE TANKS AND SWITCHES
- NO METAL PARTS IN CONTACT WITH WATER
- STARTS ON PRESSURE STOPS ON FLOW
- SUITS ALL PIPE SIZES 25mm (1") & LARGER
- AUTO RESTART AFTER RUNNING DRY
- DIRECTLY CONTROL PUMPS TO 2.4kW
- IGNORES MINOR FLOW FLUCTUATIONS
- INDICATOR LIGHTS FOR ALL FUNCTIONS
- SUITABLE FOR USE IN SEAWATER
- TOUGH RELIABLE CONSTRUCTION
- 20 Bar (300 psi) PRESSURE RATED
- WEATHERPROOF HOUSING IP67

INTRODUCTION

The F40LC Digital Pump Controller is a powerful self-contained microcomputer that controls and protects a pump under its command. The F40LC provides a seamless environment for the pump and gives the end user all the advantages of constant flow and at the same time protects the pump against damage from being run dry. Constant flow means a smooth supply free from the pressure fluctuations that plague conventional pressure controlled pumps.

THE BASIC PROBLEM

Pressure systems cycle between low and high pressure. Not because this gives the user any advantage but simply because a pressure differential is required to operate the pressure switch that normally controls such systems. The user sees the effect as annoying pressure fluctuations at the tap. If run dry for any reason, such a pressure system will run continuously and generally sustain serious damage because it has no means to sense the lack of water and shut down.

THE F40-240LC SOLUTION

The F40LC Digital Pump Controller monitors both flow and pressure and only lets the pump run if water is present. In a typical application the pump will start when there is a demand for flow or when the pressure falls. When demand ceases the controller continues to run the pump for 10 seconds to re-pressurise the system. The pump will then automatically shut down. Such a system allows the selection of a pump that has an essentially flat pressure and flow curve and delivers a steady constant pressure over widely varying flows. An air cell is not needed in the system but can be included to reduce the frequency of pump starts. With the F40LC controller the start-up pressure is set to start the pump at a pressure only marginally higher than the system's static pressure. If the demand is too low to actuate the F40LC's flow sensor, or if for any reason the pressure falls the F40LC's built in pressure sensor will detect the pressure fall, automatically run the pump, re-pressurise the system then shut down the pump and go back to monitoring the whole system.

DRY RUN PROTECTION

A pump under the control of an F40LC will start if the pressure drops, or on flow if a tap is turned on. If the system runs out of water the controller senses the loss of flow and the lack of pressure and stops the pump. A red warning light on the controller then indicates there is a problem.

AUTOMATIC RESTART FEATURE

If a pump under the control of the F40LC is run dry, the controller will shut it down and automatically try to restart it every 15 minutes for 1 hour. That is, it will try to restart the system 4 times. If the controller finds the pump is still running dry after the fourth attempt, it stops re-trying and flashes its red warning lights to indicate there is a problem.



AUSTRALIAN MADE

TECHNICAL DATA

CONSTRUCTION

The F40LC pump controller is made from high compliance thermoplastic and has no metal parts in contact with water. It operates magnetically through a seal-less coupling system. It is ideal for use in potable drinking water, aggressive bore water, seawater and a huge variety of chemical solutions.

DIMENSIONS

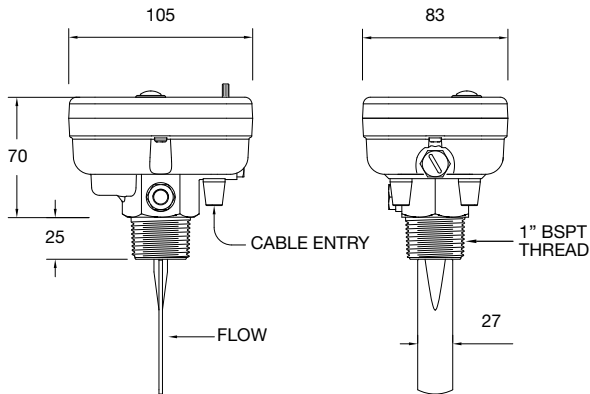

ORDERING

The F40LC Digital Pump Controller is available in two basic configurations to suit specific applications. For directly controlling pumps up to 2.4kW (3HP) It can be supplied as 'Plug & Play' with 10Amp leads and fitted with a plug and socket.

For original equipment manufacturer's applications the controller is available fitted with a single 4 core lead for wiring back into a pump motor's junction box. This arrangement allows pumps to 2.4kW (3 HP) to be directly controlled through a single cable connection to the F40LC.

F40-240LC-S

SUPPLY VOLTAGE
240 = 220 TO 240VAC

CABLE

NO LETTER = 10Amp PLUG & PLAY
S = SINGLE CABLE 2M LONG WITH 4 CORES

OPERATING ENVIRONMENT

Supply F40-240LC	220 to 250VAC 50Hz
Ambient Temperature Range	1°C to 50°C
Liquid Temperature Range	1°C to 60°C, See note
Ingress Protection Rating	IP67

OPERATING RANGE

Start-up Timer	Fixed at 30 seconds
Run-on Timer	Fixed at 30 seconds
Restart Timer	Fixed to 4 restart attempts at 6 hour intervals
Pump Start Pressure Range	0 to 5 Bars in 16 steps of 33kPa each
Maximum Starting Pressure	500kPa (72 psi)
Minimum Starting Pressure	33kPa (4.7 psi)
Recommended Pipe Sizes	25mm (1") or larger (There is no upper limit)
Maximum Switched Load All Models	250VAC 50Hz 2.4kW (Motors up to 3HP)
Operating Pressure Range, Static or Dynamic	0 to 20 Bars (0 to 300 psi), See note below
Burst Pressure	50 Bars (750 psi)

NOTE: The F40LC pump controller must NOT be used in hot water applications (>60°C). The F40LC pump controller is rated to withstand water pressure to 20 Bars (300 psi) and must not be used in applications where the static or dynamic pressure exceeds this rating.

TYPICAL PUMP INSTALLATION

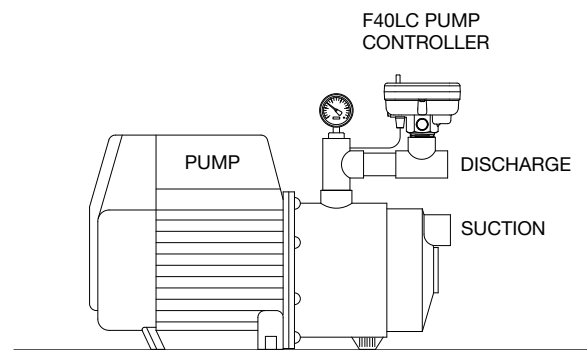

SPARE PARTS

Spare Paddles are available for the F40LC Digital Pump Controller.

WARRANTY

The Kelco F40LC Digital Pump Controller is protected by a 12 months return to base warranty. Full details of our warranty can be downloaded from: - <http://www.kelco.com.au/menu/information/warranty-statement/>

STANDARDS

The F40LC Digital Pump Controller is certified to Australian Standards: -

AS60529-2004
AS61010.1: 2003
AS/NZS CISPR 14.1:2003

Supplied to you
by

**Power
Control**
PRODUCTS

PLEASE NOTE: The Kelco F40LC Digital Pump Controller is the subject of Australian and International patent and trademark applications.

Kelco Engineering Pty Ltd reserves the right to change the specification of this product without notice. Kelco Engineering Pty Ltd accepts no liability for personal injury or economic loss as a consequence of the use of this product. All rights reserved copyright Kelco Engineering Pty Ltd © 2010

INSTALLING AND USING THE KELCO F40-240LC PUMP CONTROLLER

WARNING

Please read this installation sheet fully and carefully. The F40LC Digital Pump Controller is a mains voltage device. Death or serious injury may result if this product is not correctly installed and used.

INTRODUCTION

The F40LC pump controller is a simple to use controller. It is a microprocessor based integrated pressure and flow device. It is designed for controlling the operation of a pump and for protecting it against running dry.



WARNING

The F40LC Digital Pump Controller is water resistant to IP67. The F40LC may present a shock hazard and death or serious injury may result if water enters its electrical housing. There are no user serviceable parts in this pump controller. Under no circumstances should the main housing be opened. Warranty on this product is automatically void if the sealed body screws are opened.

IMPORTANT

This installation and usage information sheet must be read with reference to the specific model controller being installed. The power switching capacity and the pressure rating of the controllers vary from model to model and it is very important to understand the limitations of a specific controller before installing it.

MODELS

F40-240LC-S

SUPPLY VOLTAGE
240 = 220 TO 240VAC

CABLE

NO LETTER = 10Amp PLUG & PLAY
S = SINGLE CABLE 2M LONG WITH 4 CORES

OPERATING ENVIRONMENT

Supply F40-240-LC	220 to 250VAC 50Hz Single Phase
Ambient Temperature Range	1°C to 50°C
Liquid Temperature Range	1°C to 60°C
Ingress Protection Rating	IP67
Maximum Operating Pressure	20 Bars (300 psi)

OPERATING RANGE

Start-up Timer	Automatic 10 seconds
Run-on Timer	Automatic 10 seconds
Restart Timer	Automatic, 4 attempts at 15 minute intervals
Pump Start Pressure Range	Adjustable 0 to 5 Bars in 16 steps
Maximum Starting Pressure	500kPa (72 psi)
Minimum Starting Pressure	33kPa (4.7 psi)
Recommended Pipe Sizes	25mm (1") or larger (There is no upper limit)
Maximum Switched Load	250VAC 50Hz 2.4kW (Motors up to 3HP)
Operating Pressure Range, Static or Dynamic	0 to 20 Bars (0 to 300 psi), See note below
Burst Pressure	50 Bars (750 psi)

NOTE: The F40LC pump controller must NOT be used in hot water applications (>60°C). The F40LC pump controller is rated to withstand water pressure to 20 Bars (300 psi) and must not be used in applications where the static or dynamic pressure exceeds this rating.

INSTALLATION

The F40LC is suitable for use in all cold water based applications such as potable water, sea water, bore water, chlorinated pool water, brackish water or filtered effluent. A suitable location should be selected for the controller in the delivery pipework of the pump. The controller should be installed in a location that is away from both vibration and heat, preferably out of direct exposure to the weather and above any flood level. A 1" BSP socket, or threaded pipe tee must be provided in the pipework to fit the controller. The controller should be located on the top side of a horizontal section of the pipework with a minimum of 2 diameters of straight pipe either side of the controller. Under no circumstances mount the F40LC under a pipe or close to valves, tees, bends or any other obstructions likely to cause major turbulence in the flow. The F40LC can be mounted in vertical pipework if required and flow can pass either in an upward or downward direction.

In most installations the paddle of the F40LC will need to be trimmed to suit the specific pipe tee in which it is to be installed. The paddle of the controller needs a force equivalent to 20 grams dead weight acting on it from the flow in order to operate correctly. The force is generated by water in motion pushing against the exposed area of the paddle. The more area of paddle exposed to the flow the more force available to actuate the controller. Be

aware that high velocity flow can generate high forces and may damage the paddle. As a general guide the paddle of the F40LC should extend to slightly past the centre line of the pipe. The paddle would not normally be left longer than this unless the expected flow rate was very low. If you know the likely flow rate and the pipe size of your pump system there is an online calculator available at www.kelco.com.au that will help you to work out an exact size to cut the paddle. Use tin snips, side cutters or a hacksaw to cut the paddle. If needed, cut away the sides of the paddle so it clears the pipe socket and pipe walls by at least 4mm at its closest point. Apply a suitable thread sealant tape or paste and screw the F40LC into the socket using the spanner flats provided. When properly installed the controller should be square to the axis of the pipe, with the flow arrow on the side of the F40LC's body correctly oriented and parallel to the line of flow. In addition, there should be a gap of at least 4mm between the top of the 1" BSP pipe socket and the under edge of the F40LC's spanner flats. Under no circumstances should the F40LC be wound into the pipe socket until its thread bottoms out in the socket as to do so places the thread in tension and may result in the controller's housing cracking under pressure.

HOW TO INSTALL AN F40LC DIGITAL PUMP CONTROLLER

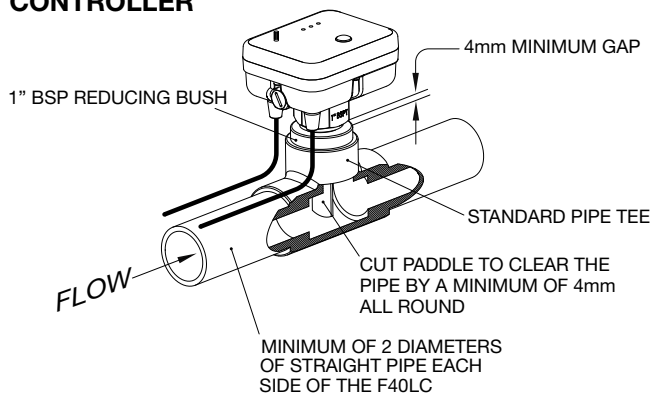

ELECTRICAL

The F40LC pump controller requires a stable supply voltage in order to operate correctly. Pay particular attention to cable sizes and ensure cables are adequate for the specific pump motor load. This is particularly important where long cable runs are to be used in the installation. If the voltage drop associated with the starting of the pump motor is excessive the F40LC will automatically reset and this may cause the pump to jog. Jogging can snap the main spindle of a pump very easily, so please take all precautions to ensure the voltage supply to the F40LC is stable and that the current carrying capacity of the cable is adequate for the job.

Never use long or coiled extension leads (longer than 5 metres) to connect a pump to the F40LC. The standard F40LC pump controller is supplied fitted with a 10 Amp plug and socket. Pumps up to 2.4kW (P1) can be plugged directly into the socket connection to the controller.

WARNING

When installing the F40LC the socket outlet connection (GPO) for the input power must be accessible and must be positioned in a dry and protected location out of the weather and above any flood or water level. Where the F40LC is to be used to control pump motors up to 2.4kW 3HP the supply to the F40LC must be protected by a 10 Amp fuse or by a 10 Amp circuit breaker.

FIXED INSTALLATION

WARNING

Fixed Installations must only ever be carried out by a licensed electrician and must conform to local wiring rules.

When used in a fixed installation a disconnecting device such as a switch or a circuit breaker must isolate the pump and F40LC. The disconnecting device must be easily and readily accessible after installation. Where a circuit breaker is used it must be rated at 10 Amp. Where an isolation switch is used the circuit must be protected by a 10 Amp fuse. In the interests of safety a 10 Amp RCD with a maximum 30mA trip should also be installed in the supply.

BROWNOUT OR BLACKOUT

If a blackout or brownout occurs while the F40LC is operating the controller will not retain any memory of where in its run or stop cycle it may have been. It will simply shut down the pump. When power resumes, the F40LC will reboot and restart the pump. A manual reboot can be done at any time by simply pressing the reset button on the top deck of the controller.

DETAILS OF THE CONTROLS

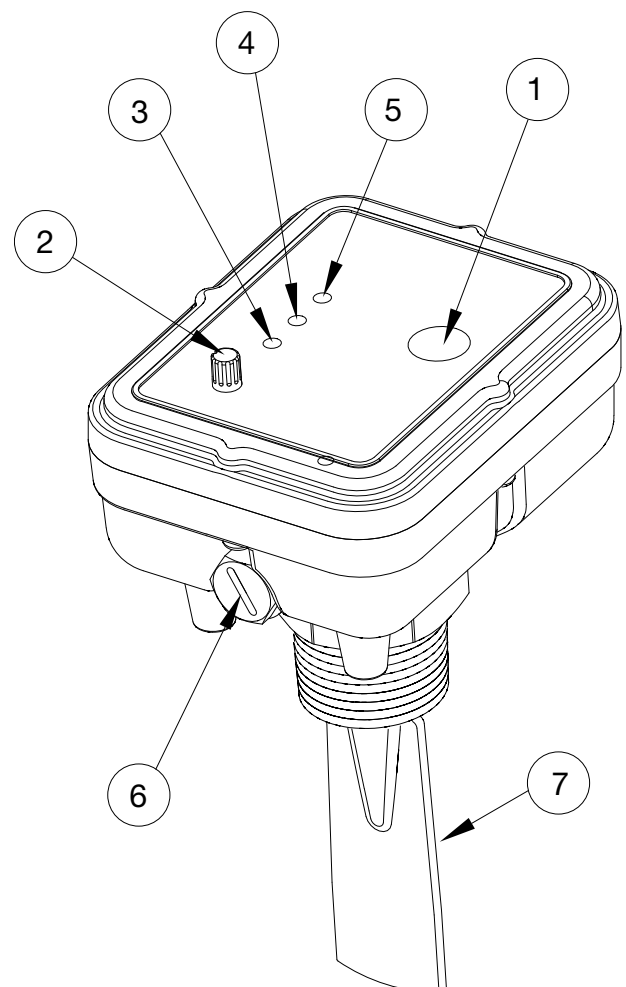

No.	DESCRIPTION	FUNCTION
1	MASTER RESET BUTTON	With power on, press this button to start the pump at any time. Always press it after making any changes to the pressure setting dial. Any changes you have made will not take effect until you press the reset button. All internal timers are reset to zero when the reset button is pressed.
2	PRESSURE SETTING	This dial sets the pump's start up pressure. The dial is adjustable from zero to 5 Bars in 16 steps. If this dial is left on zero the F40LC only senses flow and not pressure. This dial is normally set to marginally higher than the system's static pressure. When pressure falls because a tap has been turned on a point will be reached where the pressure drops to the level set on this dial. The pump then automatically starts and runs for a fixed 10 seconds. If there is a demand for flow the pump will run continuously and satisfy the demand.
3	START LIGHT	This light turns on blue whenever the pump is running.
4	FLOW LIGHT	This light turns on green whenever the F40LC detects flow. Along with the alarm light 5 it also flashes red in a coded sequence if the pump has run dry.
5	ALARM LIGHT	This light flashes red if the F40LC has been run dry. It flashes in bursts of one pulse the first time it detects a dry run. After 15 minutes the F40 automatically attempts to restart the pump. If it finds the system is still running dry it shuts down the pump and flashes this light and the flow light 4 in bursts of two pulses to indicate it is on its second try. It repeats this process every 15 minutes for an hour. After each try it adds one pulse of red light to the count. By counting the pulses you can determine how many times the F40LC has attempted to restart the system. If after four tries the system is still running dry, the F40LC goes into full alarm mode and rapidly flashes the alarm light 5 and the flow light 4 alternately red.
6	FLOW SENSITIVITY ADJUSTMENT	Under this dust cap is a screw that sets the sensitivity of the F40LC to flow. As supplied, this screw is wound fully in which is its least sensitive position. By winding this screw anti-clockwise (out) the F40LC can be set to detect progressively lower flows. In other words become more sensitive and responsive to low flows. The screw should not be wound out beyond where the dust cap can be refitted. The F40LC will not operate if this screw is fully removed. Use a wide bladed screwdriver to adjust this screw.
7	PADDLE	The paddle (a replaceable item) must be trimmed to suit the intended application. Normally the paddle is cut so when installed it intrudes to a little past the centre line of the pipe. The more area of paddle exposed to the flow the more responsive the F40LC will be. The paddle is normally trimmed with a pair of tin snips or a hacksaw. It can be narrowed down and its end rounded to suit the specific pipe in which it is to be installed. The paddle should always be trimmed so there is a minimum of 4mm clearance to the closest adjacent pipe walls. If you know the likely flow rate and the pipe size of your pump system there is an online calculator available at www.kelco.com.au that will help you to work out an exact size to cut the paddle.

SETTING THE START PRESSURE DIAL

The pressure at which the pump controller starts the pump can be set using the dial on the top deck of the controller. The starting pressure range is zero to 5 Bars (0 to 72psi). If the dial is set to zero the controller will not start if the pressure drops, it will only start if flow pushes its paddle forward. Set the dial to a pressure that you want the pump to start at. The selected pressure must be slightly higher than the system's static pressure or the pressure start function will not work. Press the reset button after making any changes to the start-up pressure, changes to the dial setting will not take effect until the reset button is pressed.

PRESSURE SYSTEMS

The F40LC pump controller can be used to protect a conventional pressure start pressure stop pump from running dry if flow is lost. In a conventional pressure system a pressure switch turns the pump on when the pressure drops and switches it off when the pressure rises. All such systems have one basic flaw, if they run out of water for any reason the lack of pressure will hold the pressure switch on and keep the pump running. The result is usually severe damage to the pump. The F40LC is an ideal alternative because it monitors flow as well as pressure and will stop the pump from running dry by detecting the loss of flow. The pump will switch on on a falling pressure and switch off when flow ceases.

AIR CELLS AND PUMPS STARTS

An air cell is not essential in a pump system controlled by an F40-240LC, but does reduce the frequency of pump starts and will generally improve the performance of the system.

An air cell can be used in a pump system to store pressure energy and provide the motive power to trigger the system and restart the pump. The F40LC relies on either pressure drop or flow to start a pump. If an F40LC is installed in a pump system before the air cell, any demand at the tap will be met by the draw off from the air cell until the pressure falls to the level set on the F40LC's pressure dial. The pump will then start and if there is an ongoing demand continue to pump. In such a system the draw off capacity of the air cell and the flow demand will determine how frequently the pump starts. A large capacity air cell will reduce the frequency of starting and thus the cycling of the pump. A small draw off air cell will give a more constant pressure but at the expense of more frequent starting.

If the F40LC is installed after the air cell, any more than a slight flow from the air cell will start the pump on flow. If the flow demand is extremely low, eventually the pump will simply start on pressure drop once the pressure reaches the pressure dial's set point. Where a system is required to supply a constant pressure the F40LC should be mounted after the air cell. When pump cycling is to be kept to a minimum, the F40LC should be mounted before the air cell and a large draw off capacity air cell should be used in the system.

SENSITIVITY ADJUSTMENT

A sensitivity adjusting screw (9) is provided for fine-tuning the F40LC. Under the end of the switch housing is a hex-headed plug that covers the adjusting screw. Remove the plug and using a broad-bladed screwdriver wind the adjusting screw anticlockwise to increase the sensitivity (reduce the flow rate needed to actuate the paddle.) As supplied, the screw is wound fully in and the F40LC is set to its least sensitive. The maximum sensitivity is reached with the screw wound out to a point where the hex dust cover can still be refitted. Normally the sensitivity screw should be left fully in. If the paddle has been trimmed too short the resultant loss of sensitivity can be offset by winding the sensitivity screw out a few turns.

LIMITATIONS

The F40LC pump controller requires a stable 220 to 240 V AC 50Hz supply in order to operate properly. Where large pumps are connected to an F40LC care should be taken to ensure cable sizes are adequate. Never use the F40LC with long or coiled extension leads or on generator sets. The electronics built into the F40LC are protected against surges and brownout and these protection systems can be triggered by voltage drop, severe voltage spikes or by an erratic electrical supply.

The F40LC should only be used in ambient temperature water applications. It is neither designed for, nor is it intended to be used with liquids other than water. The F40LC pump controller must never be used in hot water applications (greater than 60°C) and must also be protected from freezing.

The F40LC is designed to withstand water pressures up to 20 Bars (300 psi) and must not be used in applications where either the static or dynamic pressure exceeds this rating.

A PUMP SYSTEM WITH NO AIR CELL CONTROLLED BY AN F40LC

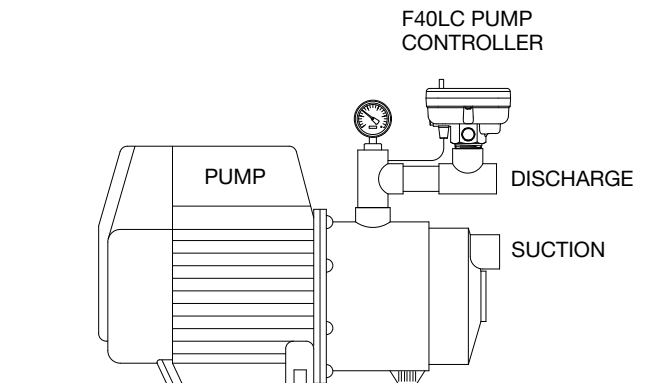

WARNING

If the F40LC Pump Controller is used in a manner not specified by the manufacturer the protection provided by the device may be impaired or negated. In addition, all warranties stated or implied will be rendered invalid.

Supplied to you
by

**Power
Control**
PRODUCTS

PLEASE NOTE: The Kelco F40LC Digital Pump Controller is the subject of Australian and International patent and trademark applications.

Kelco Engineering Pty Ltd reserves the right to change the specification of this product without notice. Kelco Engineering Pty Ltd accepts no liability for personal injury or economic loss as a consequence of the use of this product. All rights reserved copyright Kelco Engineering Pty Ltd © 2010