

MF20 MICRO FLOW SWITCHES



FEATURES

- DETECTS FLOWS OF LESS THAN 350mL /Hour
- SUITS TUBES & PIPES 6 to 20mm (1/4" to 3/4") DIA.
- NO METAL PARTS IN CONTACT WITH LIQUIDS
- SUITS PULSED OR CONTINUOUS FLOWS
- 18 BAR (260 PSI) PRESSURE RATING
- STABLE ELECTRICAL RESPONSE
- VERY HIGH FLOW THROUGH
- MANY OPTIONS AVAILABLE
- VERY LOW HEAD LOSS
- VERTICAL MOUNTING
- EASY TO INSTALL

APPLICATIONS

- CONTROL FOR BACKUP DOSING PUMPS
- CHEMICAL METERING PUMP CONTROL
- CHEMICAL INJECTION POINT STATUS
- VAPOUR & GAS FLOW DETECTION
- LABORATORY APPLICATIONS
- LOSS OF PRIME DETECTION
- BATCH CONTROL

DESCRIPTION

The MF20 micro flow switch is a super sensitive version of our popular P20 in line flow switch. The MF20 is a very simple and reliable mechanical flow switch that can detect extremely low flows; the switch can detect either continuous or pulsed flows. Typical applications include monitoring chemical metering pumps to ensure they are delivering flow, in water treatment, cooling towers and in a multitude of industrial processes. The MF20 flow switch gives a simple on or off response to liquid flow. There are no metal parts in contact with liquids within the switch, so the MF20 is ideal for use in aggressive media such as acids and alkalis and many chemical solutions. The standard switch is supplied complete with tube flare fittings, for 3 popular tube sizes, and a set of pipe spigots and unions, for direct fitting into 15NB PVC or ABS pipe work. In addition, a number of electrical options are available. These include electrical modules with single and multiple reed switches, relays with various coil voltages, and solid-state switches.

OPERATING PRINCIPLE

The body of the MF20 flow switch houses a fluted piston. Any flow, either pulsed or continuous, causes the piston to be lifted up within the switch body to a point where the liquid can pass over the piston and out of the top of the switch. The piston contains a magnet that actuates a reed switch and this provides the switching output. When flow stops, the piston sinks due to gravity, thus moving the magnet within away from the reed switch. No metal parts are in contact with the process liquid, and the simple gravity return system provides an exceptionally reliable corrosion proof mechanism. The sensitivity of the flow switch is determined by the viscosity of the fluid and by the clearance between the piston and the switch body. Three pistons are supplied with each MF20 flow switch, with accurate and predictable switch points ranging from 0.32 litres per hour to 12.8 litres per hour. The MF20 flow switch must be mounted vertically with flow upward through the switch body. The switch can be mounted directly on the suction or discharge valve of a metering pump.

CONSTRUCTION

The Micro flow MF20 flow switch is made from glass-reinforced polypropylene with EPDM O-ring seals and PVC spigots. These are the only materials that come in contact with liquids passing through the switch. A high power rare earth magnet operating through the solid body of the switch actuates the MF20 electrically. The electrical housing is weatherproof to IP67, and is supplied with an integral 20mm cable gland, for conduit or cable entry. The electrical circuit boards used in the switch are interchangeable, and all of the parts of the MF20 flow switch are available as spare parts.



AUSTRALIAN MADE

TECHNICAL DATA

FLOW SENSITIVITY AND RESPONSE TIME

Sensitivity to fluid flow is a function of liquid viscosity and piston clearance. There are 3 pistons available to suit the MF20 flow switch. Each piston has a distinct switching point. The pistons are designated and marked A, B and C. The "A" piston is fitted to the MF20 flow switch as standard. The optional "B" and "C" pistons are also supplied packed in with each switch. The following table sets out the performance parameters of the 3 pistons. The data is based on testing with water at 15°C as the test medium, and is accurate to +/-10%. Changes in liquid viscosity or temperature will affect the switching point. Increases in viscosity will proportionally decrease the flow rate required to actuate the switch, and will proportionally increase the response time. Decreasing viscosity will proportionally increase the flow required to actuate the switch, and will proportionally decrease the response time.

Note: In pulsed flow applications where no pulse dampener is installed, and the pulse frequency is less than the electrical response time, the MF20 flow switch may respond with a train of on / off pulses rather than with a continuous on signal.

Piston Markings and Designation	Switching Point on a Rising Flow in Litres per Hour	Switching Point on a Reducing Flow in Litres Per Hour	Electrical Response Time in Seconds on Cessation of Flow
A	0.32	0.30	4
B	3.10	3.05	3
C	12.80	12.6	2

Please Note: The type "A" piston is supplied as standard fitted to each switch, unless otherwise specified. The B & C pistons are included packed in with each switch.

The graph shows the dynamic head loss across the MF20 flow switches. The data refers to water at 15°C as the test medium.

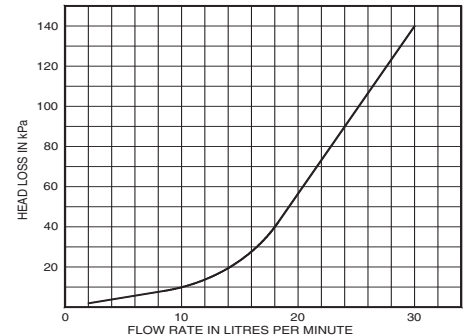

DIMENSIONS

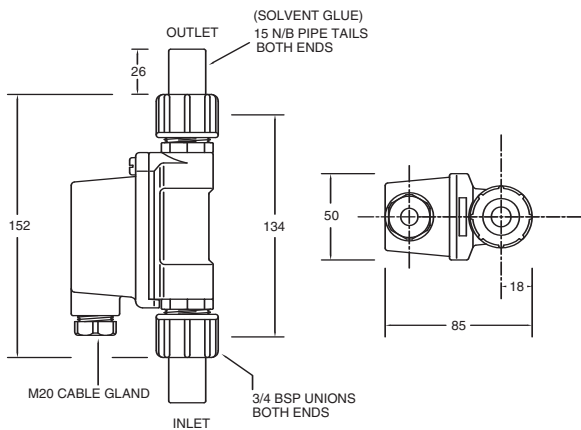

OPERATING ENVIRONMENT

Maximum Recommended Operating Pressure (Static or Dynamic) at Ambient Temperature	1800 kPa (260 P.S.I.)
Minimum Burst Pressure at Ambient Temperature	9700 kPa (1400 P.S.I.)
Maximum Liquid Temperature (Standard MF20 Switch)	80 Degrees C at a pressure 1 bar absolute, see note below
Minimum Liquid Temperature (Standard MF20 Switch)	-30°C
Maximum Recommended Continuous Flow Rate (Water)	25 Litres per Minute (Head loss across the switch <100kPa at 25L/min)
Liquid Ph range	1 to 14
Ingress Protection Rating (Weatherproof Rating)	IP67

Note: Temperature for the maximum operating pressure shown in the above operating environment table is 15°C. In the interest of safety, maximum operating pressure must be de-rated linearly in direct proportion to temperature increase, to a maximum pressure of 1 bar absolute at 80 degrees Centigrade. In other words only use this switch at elevated temperatures in non pressurised systems that are totally open to atmosphere in all circumstances and under all conditions.

ELECTRICAL DATA

The MF20 in line flow switch is available in a variety of electrical configurations, to suit specific applications. The model numbers and details of these options are outlined in the table below.

Switch Model	Module Type	Contact Configuration	Switched Power Maximum	Switched Voltage Maximum	Switched Current Resistive AC (rms) Maximum	Inductive Loads (Power Factor 0.4)	Typical Application
MF20-B	Dry Reed Switch	S.P.S.T. N.O	40W	240V AC 200V DC	1A	Not Suitable	PLC and General Control Circuits
MF20-C	Dry Reed Switch	S.P.D.T.	40W	240V AC 200V DC	1A	Not Suitable	PLC and General Control Circuits
MF20-R	Solid State Relay (Triac)	S.P.S.T. N.O	750W	2 to 240V AC	4A Continuous (Spike to 16A)	4A at 240V AC	AC Control Circuits and AC Motor Control to 1 HP
MF20-A240	Standard Relay 240V AC Coil	S.P.D.T.	2500VA at 250VAC 300VA at 30VDC	0 to 240 V AC	10A	7.5A at 240V AC 5A at 30V DC	General AC or DC Control
MF20-A24	Standard Relay 24V AC Coil	S.P.D.T.	2500VA at 250VAC 300VA at 30VDC	0 to 240V AC	10A	7.5A at 240V AC 5A at 30V DC	General AC or DC Control

Note: The MF20 flow switch uses reed switches as the primary switching element. Reed switches are one of the most reliable mechanical switching devices ever devised. They offer an operating life in excess of 100 million cycles, however, care needs to be taken to ensure they are not electrically overloaded or if applied in questionable applications, suitable protection should be added to the control circuit.

Power Control
PRODUCTS

Unit 3, 8 Hayden Court, Myaree WA 6154
Phone (08) 9317 4322, Fax (08) 9317 4465
www.powercontrol.com.au

Supplied to you
by

Power Control
PRODUCTS

PLEASE NOTE: Kelco Engineering Pty Ltd reserves the right to change the specification of this product without notice. Kelco Engineering Pty Ltd accepts no liability for personal injury or economic loss as a consequence of the use of this product. All rights reserved copyright Kelco Engineering Pty Ltd © 2008.

INSTALLATION AND OPERATING SHEET FOR MF20 MICRO FLOW SWITCH

INTRODUCTION

The MF20 micro flow switch is a vertically mounted in line piston flow switch that is supplied preset to switch on or off at a specific flow rate. The body of the switch contains a piston that obstructs the line of flow. The process fluid, either a liquid or a gas enters the bottom of the switch and must push the piston up until it can flow over the piston and out the top of the switch. When the piston is pushed up by flowing fluid, a magnet inside the piston actuates a reed switch in the electrical enclosure; this provides a set of closed, (or open) electrical contacts that can be used in control circuits, to indicate flow. When flow stops the piston sinks down, due to gravity and in doing so, moves the magnet out of proximity of the reed switch, thus de-actuating the reed switch.

OPERATING ENVIRONMENT

The MF20 micro flow switch has no metal parts in contact with the process fluid. Inert thermoplastics are all that come in contact with the liquid passing through the switch. This means the MF20 can be used in aggressive chemical solutions and in many fluids that would attack metal parts. The MF20 flow switch contains a close fitting piston, and should only be used in applications where the process fluid is reasonably clean and free of entrained or suspended material. Fluids containing large particulate matter, ferrous materials or fibrous matter should not be used in this switch. If the degree of contamination of the process fluid can't be guaranteed, then suitable line filtration should be fitted to the system downstream of the MF20 flow switch.

The principle environmental limitations of the MF20 micro flow switch are set out in the following table

Maximum Recommended Operating Pressure (Static or Dynamic) at Ambient Temperature	1800 kPa (260 P.S.I.)
Minimum Burst Pressure at Ambient Temperature	9700 kPa (1400 P.S.I.)
Maximum Liquid Temperature (Standard MF20 Switch)	80 Degrees C at a pressure 1 bar absolute, see note below
Minimum Liquid Temperature (Standard MF20 Switch)	-30°C
Maximum Recommended Continuous Flow Rate (Water)	25 Litres per Minute (Head loss across the switch <100kPa at 25L/min)
Liquid Ph range	1 to14
Ingress Protection Rating (Weatherproof Rating)	IP67

Important Note: Temperature for the maximum operating pressure shown in the above operating environment table is 15°C. In the interest of safety, maximum operating pressure must be de-rated linearly in direct proportion to temperature increase, to a maximum pressure of 1 bar absolute at 80 degrees Centigrade. In other words only use this switch at elevated temperatures in non pressurised systems that are totally open to atmosphere in all circumstances and under all conditions.

CHEMICAL COMPATIBILITY

The standard MF20 micro flow switch is constructed from glass-reinforced polypropylene with EPDM O-ring seals. Specific data on the chemical compatibility of polypropylene and EPDM can be obtained from widely available chemical compatibility charts, or from the manufacturer, on request. The MF20 flow switch is weatherproof to IP67, and is suitable for all outdoor exposed applications. The switch should be protected from freezing and not be exposed to fluid temperatures in excess of 80°C. The MF20 flow switch should not be used in applications where the line pressure exceeds 18 bars, the switch has a burst pressure rating of >70 bars. Care should be taken not to expose the switch to excess pressures such as may be generated by the high acceleration heads from some metering pumps, or from water hammer.

INSTALLATION

The MF20 micro flow switch must be mounted vertically in the pipe work, with flow passing upward through the switch body. There is a direction of flow arrow on the switch body; this directionality must be adhered to, as the switch will not operate against a reversed flow. A comprehensive selection of pipe spigots and tube flare fittings are supplied with each switch. In most instances these fittings will prove sufficient to allow installation of the switch without the need for any special components. Pipe work can be used to support the switch, or the switch can be connected directly onto the discharge valve of a metering pump. The MF20 is terminated with 3/4" BSPP male threads. These can be screwed directly into pipe sockets, and used in 3/4" piping. In addition the switch is supplied with 3/4" unions and 1/2" (15NB) spigots. The spigots are thick walled and designed to be tapped 1/4BSP, for use with compression fittings, if required. The pipe spigots supplied with this switch constructed from PVC. Both types are suitable for solvent gluing directly into 15N/B PVC or ABS pipe fittings.

In addition to the pipe spigots, each MF20 flow switch is supplied with 3 sets of tube flare fittings, these suit 6 by 5, 8 by 4 and 12 by 9 flexible tube.

FLOW SENSITIVITY & RESPONSE TIME

Sensitivity to fluid flow is a function of liquid viscosity and piston clearance. There are 3 pistons available to suit the MF20 flow switch. Each piston has a distinct switching point. The pistons are designated and marked A, B and C. The MF20 micro flow switch is supplied as standard with the "A" piston. The optional "B" and "C" pistons are also supplied with each switch. The following table sets out the performance parameters of the 3 pistons. The data is based on testing with water at 15°C as the test medium, and is accurate to +/-10%. Changes in liquid viscosity will affect the switching point. Increases in viscosity will proportionally decrease the flow rate required to actuate the switch, and will proportionally increase the response time. Decreasing viscosity will proportionally increase the flow required to actuate the switch, and will proportionally decrease the response time. Pistons are changed by unscrewing the inlet adaptor (part No 2), and inserting the new piston. Note the spanner octagon on the inlet adaptor accepts a standard gas cylinder spanner (28mm across the flats).

Note: In pulsed flow applications where no pulse dampener is installed, and the pulse frequency is less than the electrical response time, the MF20 flow switch may respond with a train of on/off pulses rather than with a continuous on signal.

Piston Markings and Designation	Switching Point on a Rising Flow in Litres per Hour	Switching Point on a Reducing Flow in Litres Per Hour	Electrical Response Time in Seconds on Cessation of Flow
A	0.32	0.30	4
B	3.10	3.05	3
C	12.80	12.6	2

Please Note: The type "A" piston is supplied as standard fitted to each switch, unless otherwise specified. The B & C pistons are included packed in with each switch.

ELECTRICAL

The MF20 micro flow switch is available in a variety of electrical configurations, to suit specific applications. The model numbers and details of these options are outlined in the table below. The model of a specific switch can be found on a label inside the lid of the electrical housing of every switch.

The electrical enclosure on the MF20 switch is accessible by removing one screw on the lid. The lid has an integral 20mm cable gland designed to accept flexible cable up to 10mm diameter, or the gland nut can be removed and the exposed female thread will then accept a 20mm conduit bush. Various electrical options are available for the MF20 flow switch. Details of the specific circuit board module, including its model number are located inside the lid of the electrical housing of each switch. All the available electrical modules use a reed switch as the primary switching element. The contacts of the reed switch open and close in response to the position of the switch piston magnet. The reed switch may be the primary switch, or it may be used to drive a triac or a relay that is included on the circuit board in the switch. Where the reed switch is used as the main switch, care should be taken to ensure it is not overloaded. Reed switches are very reliable devices but may be damaged easily if overloaded. Use interposing relays and avoid inductive loads, fit suitable protection such as diodes or rate effect suppression circuits. Avoid capacitive coupling effects associated with long cable runs, use shielded cable in such situations, and fit diode protection to the reed switches in DC applications.

The MF20 switch can be tested for electrical function in the following way. With the switch isolated and held vertically, place a continuity tester across terminals S1 and S2. (Do not use a lamp tester for this, due to the high inrush current.) Use a pencil or similar object to lift the piston within the switch. Each time the piston is lifted a closed circuit should appear across S1 and S2. The piston is accessed by pushing the pencil straight up the centre of the switch, through the centre of the inlet fitting. This test should be done dry, and without the switch in the pipework. Each time the piston is released it should fall freely to the off position, and the switch should respond with an open circuit across terminals S1 and S2.

MAINTENANCE

This flow switch is a very low maintenance device. If The MF20 flow switch is correctly installed and if the process fluid is compatible with the materials of construction of this switch, then a very long service life can be expected. Factors that may contribute to early failure of this device include excess temperature, excess pressure or electrical loads in excess of the electrical modules ratings.

All of the components of this switch are available as spare parts, as listed below.

ITEM	DESCRIPTION	QTY	MATERIAL
1	SWITCH BODY	1	GLASS REINFORCED POLYPROPYLENE
2	INLET ADAPTOR	1	GLASS REINFORCED POLYPROPYLENE
3	O RING SEAL	2	EPDM ELASTOMER
4	MAIN LID GASKET	1	SANOPRENE
5	CABLE GLAND NUT	1	GLASS REINFORCED POLYPROPYLENE
6	CABLE GLAND THRUST RING	1	GLASS REINFORCED POLYPROPYLENE
7	CABLE GROMMET	1	SANOPRENE
8	LID	1	GLASS REINFORCED POLYPROPYLENE
9	LID FIXING SCREW	1	M5 BY 16 STAINLESS STEEL
10	PISTON	1	GLASS REINFORCED POLYPROPYLENE
11	MAGNET CASE	1	GLASS REINFORCED POLYPROPYLENE
12	TERMINAL BLOCK	1	ACETAL RESIN
13	OUTLET ADAPTOR	1	GLASS REINFORCED POLYPROPYLENE
14	CIRCUIT BOARD FIXING SCREW	2	M4 BY 6 STAINLESS STEEL PAN HEAD
15	CIRCUIT BOARD ASSEMBLY	1	COMPLETE ELECTRICAL MODULE
16	UNION NUT	2	GLASS REINFORCED POLYPROPYLENE
17	20N/B PIPE TAIL	2	PVC
18	O RING SEAL	2	EPDM ELASTOMER
19	12 BY 9 TUBE ADAPTORS	2	ABS
20	8 BY 4 TUBE ADAPTORS	2	ABS
21	6 BY 5 TUBE ADAPTORS	2	ABS

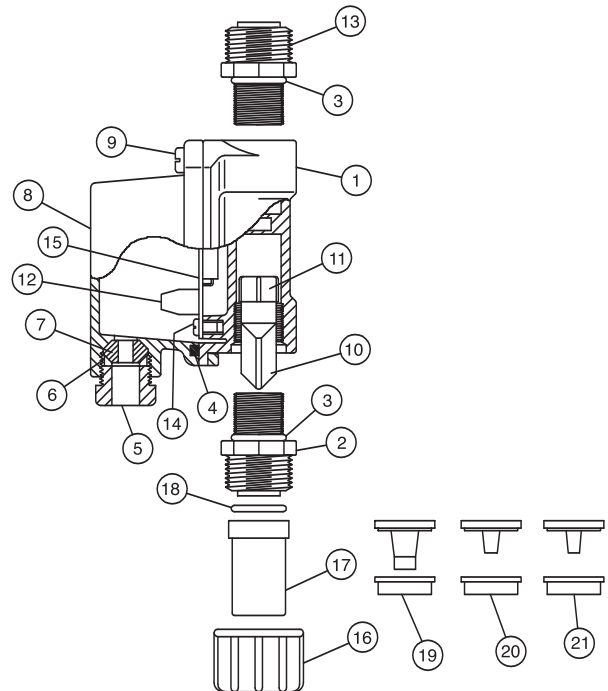

PARTS LIST MF20 MICRO FLOW SWITCH

The MF20 in line flow switch is available in a variety of electrical configurations, to suit specific applications. The model numbers and details of these options are outlined in the table below.

Switch Model	Module Type	Contact Configuration	Switched Power Maximum	Switched Voltage Maximum	Switched Current Resistive AC (rms) Maximum	Inductive Loads (Power Factor 0.4)	Typical Application
MF20-B	Dry Reed Switch	S.P.S.T. N.O	40W	240V AC 200V DC	1A	Not Suitable	PLC and General Control Circuits
MF20-C	Dry Reed Switch	S.P.D.T.	40W	240V AC 200V DC	1A	Not Suitable	PLC and General Control Circuits
MF20-R	Solid State Relay (Triac)	S.P.S.T. N.O	750W	2 to 240V AC	4A Continuous (Spike to 16A)	4A at 240V AC	AC Control Circuits and AC Motor Control to 1 HP
MF20-A240	Standard Relay 240V AC Coil	S.P.D.T.	2500VA at 250VAC 300VA at 30VDC	0 to 240 V AC	10A	7.5A at 240V AC 5A at 30V DC	General AC or DC Control
MF20-A24	Standard Relay 24V AC Coil	S.P.D.T.	2500VA at 250VAC 300VA at 30VDC	0 to 240V AC	10A	7.5A at 240V AC 5A at 30V DC	General AC or DC Control

Note: The MF20 micro flow switch uses reed switches as the primary switching element. Reed switches are one of the most reliable mechanical switching devices ever devised. They offer an operating life in excess of 100 million cycles, however, care needs to be taken to ensure they are not electrically overloaded or if applied in questionable applications, suitable protection should be added to the control circuit.



**Supplied to you
by**



PLEASE NOTE: Kelco Engineering Pty Ltd reserves the right to change the specification of this product without notice. Kelco Engineering Pty Ltd accepts no liability for personal injury or economic loss as a consequence of the use of this product. All rights reserved copyright Kelco Engineering Pty Ltd © 2008.