

EOCR-DS1 Inverse Overload Relay

Samwha



Features

- Microprocessor based inverse overload, locked rotor & phase loss protection
- Independent starting & trip delay adjustment
- Wide current adjustment range
- Power on and trip indication LEDs
- Remote electrical reset
- Low energy consumption, compact design
- Operates in wide temperature range

Benefits

- High accuracy, no damage to motors due to phase loss
- Allows high inertia starting with a fast trip curve
- Reduced spares inventory
- Assists in fault finding
- Safe resetting
- Less cubical space required
- Consistent accuracy

The Samwha DS1 overload relay has been designed to suit most industrial 3 phase motor protection applications. Current ranges from 0.5 amps to 30 amps are achieved by just two relays eliminating the need for large numbers of spares. The three motor cables are fed through the body of the relay via three current transformer windows which accommodate cables up to 10mm in diameter. Alternatively the relay can be supplied with a power terminal kit allowing hard wire connection of the motor cables. For current ranges above 30 amps and up to 400 amps, an external current transformer block part number SR-3CT is installed in conjunction with the EOCR-DS1-05N.

Compact design and advanced features including definite time phase loss protection make it superior to any existing bi-metal overload. It is simple to install being DIN rail or surface mounting and is comparable in price to thermal overload relays. The relay can be reset either manually or electrically allowing remote reset as standard.

Ordering information

EOCR-DS1 --- - N - --- Control voltage 024,110,220
 Fail safe
 Current range 05 or 30 amps

OPTIONS SR-3CT --- Ratios 100:5,150:5,200:5,300:5,400:5
 DST --- Power terminal kit

For further details please contact your Samwha distributor.

Specifications

TRIP TIMES	
Overload	See Time/Current Curves (1-10s)
Phase Loss	4 seconds
CURRENT SETTING RANGE	
05 Type	0.5 - 5 amps
30 Type	3.0 - 30 amps
START CURRENT TRIP DELAY	
1.0 - 50 seconds	
CONTROL VOLTAGES	
024 (24 Vac/dc)	
110 (85-150 Vac)	
220 (180-260 Vac)	
FREQUENCY	50/60 Hz
OUTPUT RELAY	
1N/O,1N/C 5A/250Vac Resistive	
OPERATING CHARACTERISTIC	
Inverse	
TRIP INDICATION	LED
FAULT INDICATION	LED
TOLERANCE	
Current	+/- 10%
Time	+/- 10%
AMBIENT TEMPERATURE	
Storage	-30 - 80 °C
Operation	-25 - 70 °C
Humidity	45 - 85% without condensation
INSULATION	
Between casing and circuits Over 10MΩ @ 500 Vdc	
DIELECTRIC STRENGTH	
Casing & circuit	2kV
Between contacts	1kV
Between circuits	2kV
POWER CONSUMPTION	
Less than 3 VA	
MOUNTING	
35mm DIN Rail/surface	

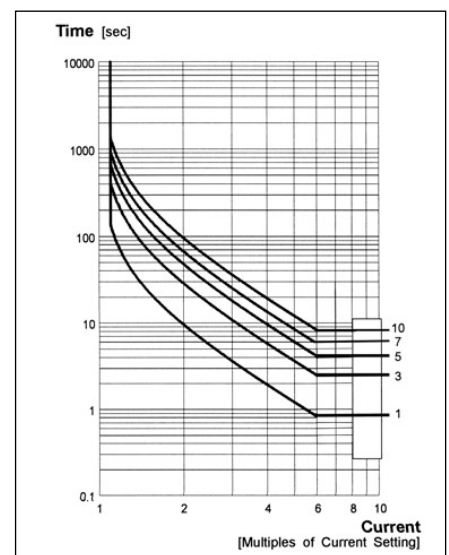

Time current curves

Adjustments

The relay fascia has three adjustments:

- 1) Current adjustment
- 2) Starting trip delay time
- 3) Trip time adjustment

Each adjustment potentiometer is calibrated so the relay can be accurately set with no control power applied.

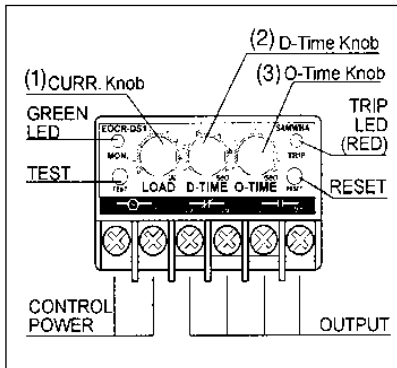

Motor Status		LED Output / Pulse Signal				
		Green LED		Red LED		
1	Stop(Power Input)	Flashing		Off		
2	Starting	Flashing		Flashing		
3	Normal Running	On		Off		
4	Overloading	On		Flashing		
5	Trip	Over-current	Off		Off	
		Locked Rotor	Off		Flashing	
	Loss	R	Off		Flashing	
		S	Off		Flashing	
	T	Off		Flashing		

Indication

The EOCR-DS1 gives full indication of motor status via two LEDs mounted on the fascia. These illuminate independently or together in differing sequences according to motor status (see table above).

Setting Instructions

Once all connections to the EOCR-DS1 have been made in accordance with the typical wiring diagram, apply control power to terminals L1 and L2. The green LED will light flash indicating a ready state.

- Set the current adjustment (1) to the desired level. Each relay is individually calibrated with a black dot near the corresponding current value.
- Set the starting trip delay (2). This time should be as close as possible to the normal motor starting or run up time. The relay will trip on locked rotor fault when this time has expired and motor current is $>300\%$ of current setting.
- Set the trip time adjustment (3) according to the required trip curve characteristic shown on page 1. If 5 is selected, the 5 second curve is selected and so on.

Test and Reset

- Press the test button and hold it down until the relay trips. The red and green LEDs flash together for the period of the D Time. Once the D-Time is exceeded, the green LED stays on and only red LED flashes indicating the relay is now in O-Time and a trip is imminent. The amount of time the relay takes to trip is approximately equivalent to the combination of the D Time

setting and the O Time setting. During the test sequence, the simulated motor current is $<300\%$ of the relay load setting.

- The relay trips, the green LED goes off and the red LED remains on until the relay is reset.
- Reset the relay by pressing the reset button on the fascia or by momentarily interrupting the control power to terminals L1 and L2. The green LED will then flash indicating control power is available and the relay is ready for use.

Mounting

The EOCR-DS1 is 35mm DIN rail mounting and is supplied with a bracket for surface mounting if required. It can be mounted in any orientation without affecting performance.

Phase Loss

Phase loss protection is standard for all EOCR-DS1 relays and does not need to be selected.

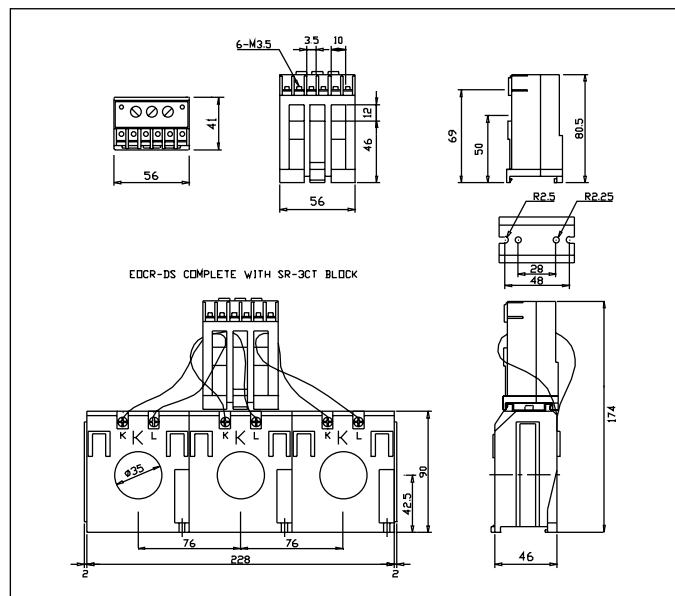

Dimensions (power terminals can be supplied separately)

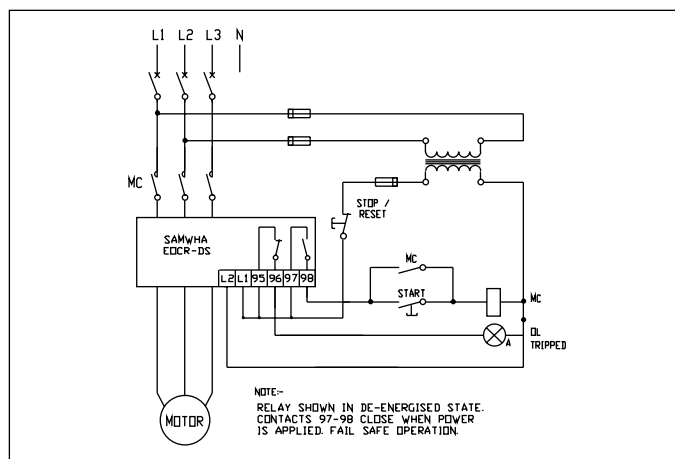

Typical wiring diagram

Details may be subject to change without notice.

Doc EOCR-DS1-Rev1, Feb 2000. © R&D Technology PTY LTD

Australian Distributors

R&D Technology PTY LTD
 PO Box 192
 Wickham NSW 2293
 PHONE 02 4962 1282
 FAX 02 4962 1522
 EMAIL sales@rdtechnology.com.au

Supplied by