

SAFE-T-DRIFT

7mm minimum from the belt edge to the under side of the Switch

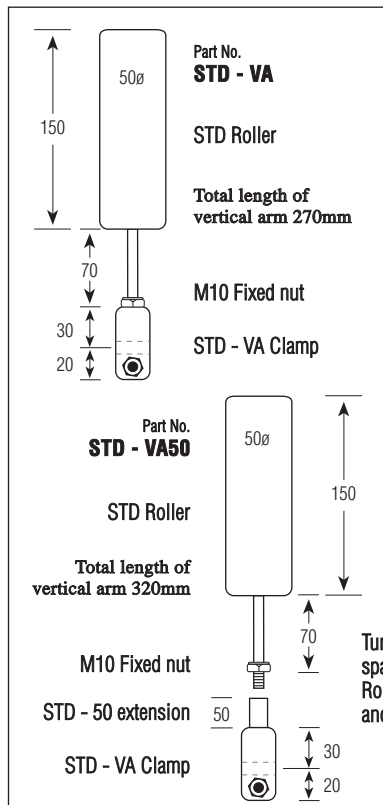
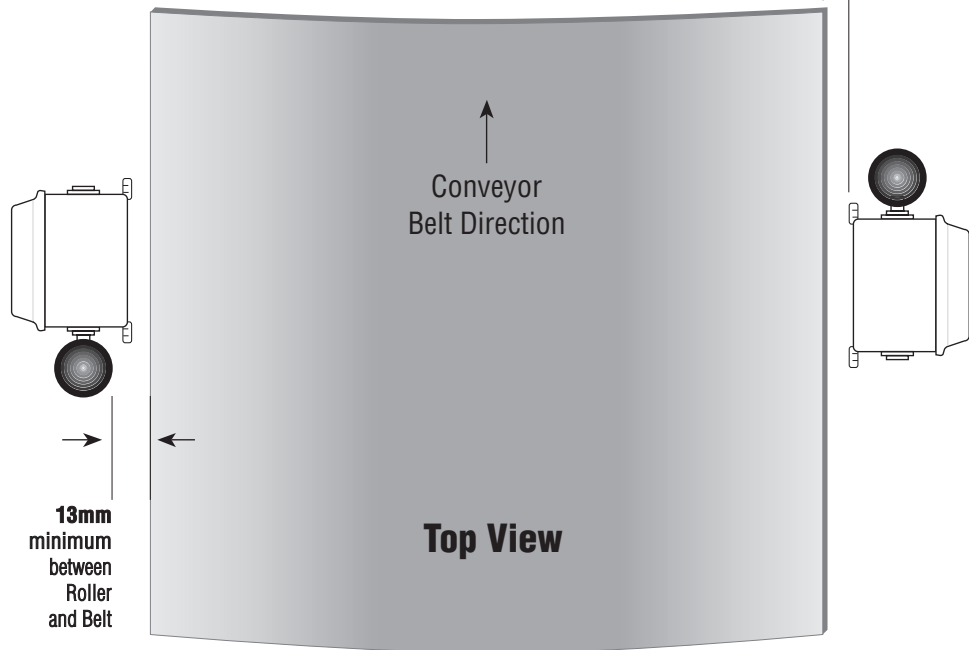

VERTICAL ARM

Part No's: STD-VA; STD-VASR; STD-VA50

Installation Instructions

Recommended Belt Drifts to use with STD-VA / VASR / VA50
Part No's: STD-P/-? STD-P-K/-?

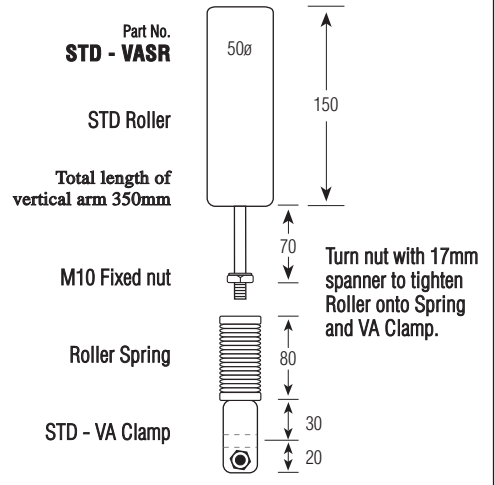

The roller arm has the ability to rotate 90° from its set resting position in both directions, so that you can get maximum belt drift travel and maintain switch & roller reliability. The arm returns to its set resting position when the belt returns to its normal running position.

Using the Part No. STD-P-LATCH the arm can be preset to a position where the belt drifts and trips the switch, and the arm rotates over to the 90° position and only returns when it is physically pushed back to position and then the conveyor may be restarted.

Eg. Use the roller arm as a Belt Drift Switch visual flag indicator.

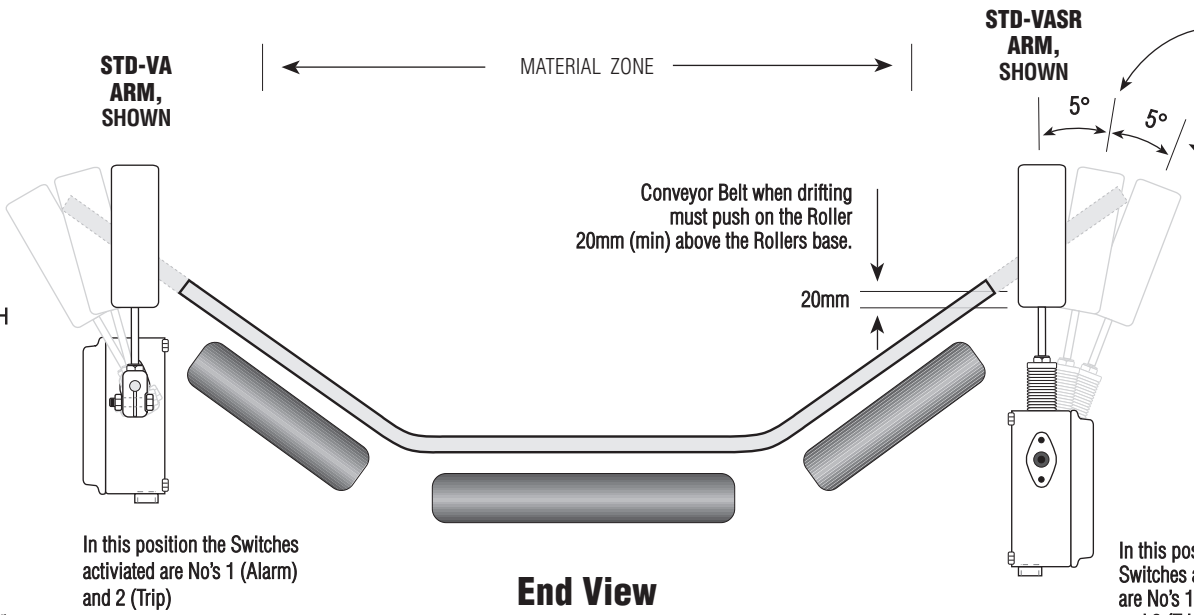

FACTORY SET LIMIT SWITCH ALARM POSITION (ALARM LIMIT SWITCH ON)
(Factory Setting may be changed after Switch Installation to required position. See Micro Switch Installation Instructions for adjustment)

FACTORY SET LIMIT SWITCH TRIP POSITION (TRIP LIMIT SWITCH ON)
(Factory Setting may be changed after Switch Installation to required position. See Micro Switch Installation Instructions for adjustment)

Limit switch trip position to be set anywhere before the Conveyor Belt rides over the top of the roller.



Unit 3, 8 Hayden Court, Myaree WA 6154
Phone (08) 9317 4322, Fax (08) 9317 4465

Made in Australia