

SMARTSTART - 480

INSTRUCTION MANUAL

SMARTSTART 480

Table of Contents

Model Information	1
Receiving	1
Electrical Specifications	2
Mechanical Installation	3
Power Wiring Diagrams	4
Control Wiring Diagrams	6
Diagnostic / Status Indication	7
Smartstart Adjustments	8
Start Up Procedure	10
Other Features	11
Application Considerations	12
Smartstart Trouble Shooting	13
Testing SCR Assemblies	14
Appendix A Fuse Rating	15
Appendix B Pump Profile Settings	16

SMARTSTART 480 Model Information

Model	Cyclic	Continuous	Bypass
A80	85A	80A	92A
A115	125A	115A	145A
A175	195A	175A	220A
A300	345A	300A	360A
A450	530A	450A	550A
A600	750A	650A	830A

- all ratings are 3 Wire connected medium duty load.
- cyclic rating is continuous running with a minimum 2 minute cool down before restart.
- all figures based on 12 starts per hour.

RECEIVING

Inspect the Smartstart for any shipping damage, if found report it to the carrier immediately.
Access the inside of the Smartstart and check for internal damage.

**DO NOT ATTEMPT
TO OPERATE THE SMARTSTART IF ANY OBVIOUS DAMAGE EXISTS**

SMARTSTART 480

ELECTRICAL SPECIFICATIONS

ELECTRICAL

Motor Supply:	208-480 V AC (+10%,-10%)
Frequency:	50/60Hz (automatic adjustment)
Power Circuit Fusing:	Ultra-fast semiconductor fuses included as standard
Equipment Grounding:	Earth stud provided on top of chassis
PIV Rating:	1400 V DC minimum
dv/dt suppression:	RC snubber network
Motor Configuration:	3 wire or 6 wire connected
Control Supply:	110/220 – 240 V AC (+10%,-10%)
Start/Stop Supply:	110/220 – 240 V AC (+10%,-10%)
Start/Stop:	110 – 240 V AC two or three wire control
Power Consumption:	60 VA maximum for control circuitry
Control Circuit Fuse:	2A HRC fuse (customer supplied)

ENVIRONMENTAL

Operating Temperature:	0°C to 55°C (derate 1% per °C above 45°C)
Humidity:	0% to 95% non condensing
Altitude:	1000m ASL Maximum
Airborne Matter:	Suitable for non conducting and non flammable dusts only
Storage:	Clean dry location -20°to 60°C
Protection Bag:	IP00

FUNCTIONAL

Ramp Control:	1, 2, 5, 10, 20, 30, 45, 60 seconds
Ramp Type:	Linear increase in SCR conduction angle
Extended Stop Control:	0.5, 1, 2, 4 times selected acceleration time
Pump Stop Control:	(Optional) adjustable deceleration profile to minimise water hammer
Current Limit Control:	200, 225, 250, 275, 300, 325, 350, 375, 400, 450% of nominal FLC
Pulse Start:	0.5, 1.0, 2.0, s of near full voltage for starting positive displacement pumps and loads that stick firm at rest
Status Indication:	Power On, Standby, Accelerating, Up to Speed, Bypass Mode, Decelerating, Energy Save, 3 Wire Mode
Fault Indication:	Fault, Control Voltage, Bypass Fault, Overtemperature, Phase Reversal, Motor Stalled, Phase A,B,C
Relay Output:	Healthy run condition is signalled by a set of change over contacts
Bypass Conductor Signal:	Normally open contact closes for bypass
Relay Contact Rating:	5A @250 V AC or 5A @ 30V DC resistive, @A @ 250V AC inductive
Maximum Duty Cycle:	FLC continuously
Medium Duty Cycle:	300% FLC 30 seconds 200% FLC 60 seconds
Heavy Duty Start:	450% FLC 30 seconds 300% FLC 60 seconds

PROTECTION

Phase Loss:	Loss of phase upstream or downstream controller
SCR Fault:	Detection of short circuit, open circuit or firing faults on SCRs
Motor Stall:	Detection of stalled or underspeed motor condition
Auto Restart:	Unit will restart on fault trip condition for 3 consecutive attempts
Overtemperature:	Thermal sensor controls cooling fans and overtemperature trip
Short Circuit:	Ultra-fast semiconductor fuses included as standard

MECHANICAL INSTALLATION

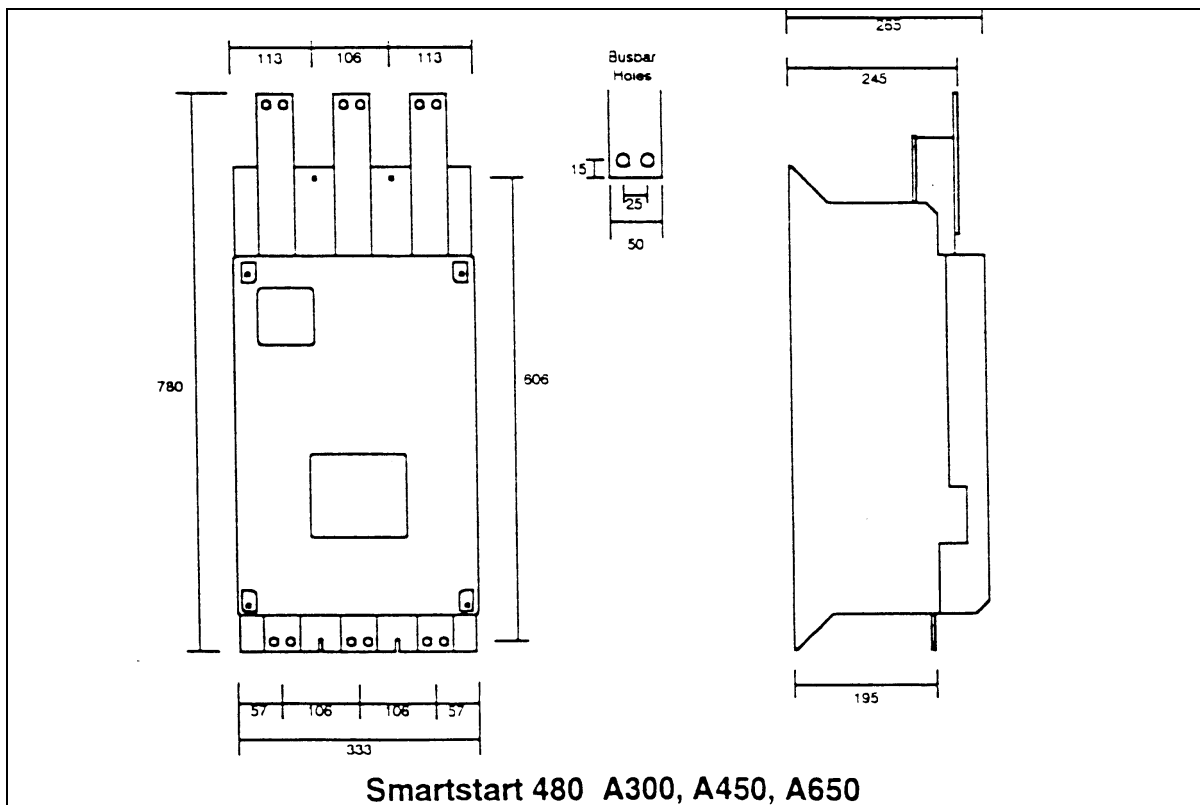
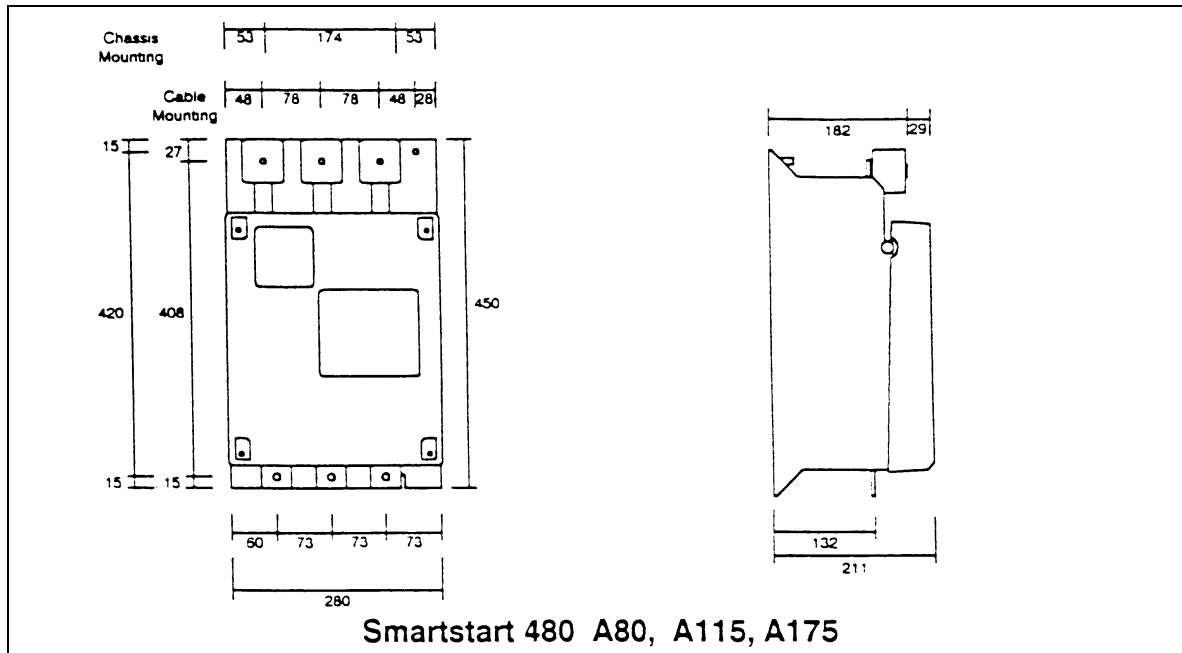

IMPORTANT NOTES

- All Dimensions in millimetres
- Always mount in dust free environment
- Always mount in a vertical position
- Allow 200mm free air space top and bottom
- All mounting holes are 8mm clearance
- Make allowance for high ambient temperatures

POWER WIRING 3 Wire Connections

There are two methods of configuring the power wiring to the Smartstart, 3 Wire or 6 Wire. To wire the Smartstart in 3 Wire the motor terminals of the Smartstart are connected to either a Star or Delta connected motor. The 6 Wire connection is sometimes referred to as an inside delta connection, and is best shown on pages 5 of this manual. The 3 Wire connection is used in nearly all applications of the Smartstart.

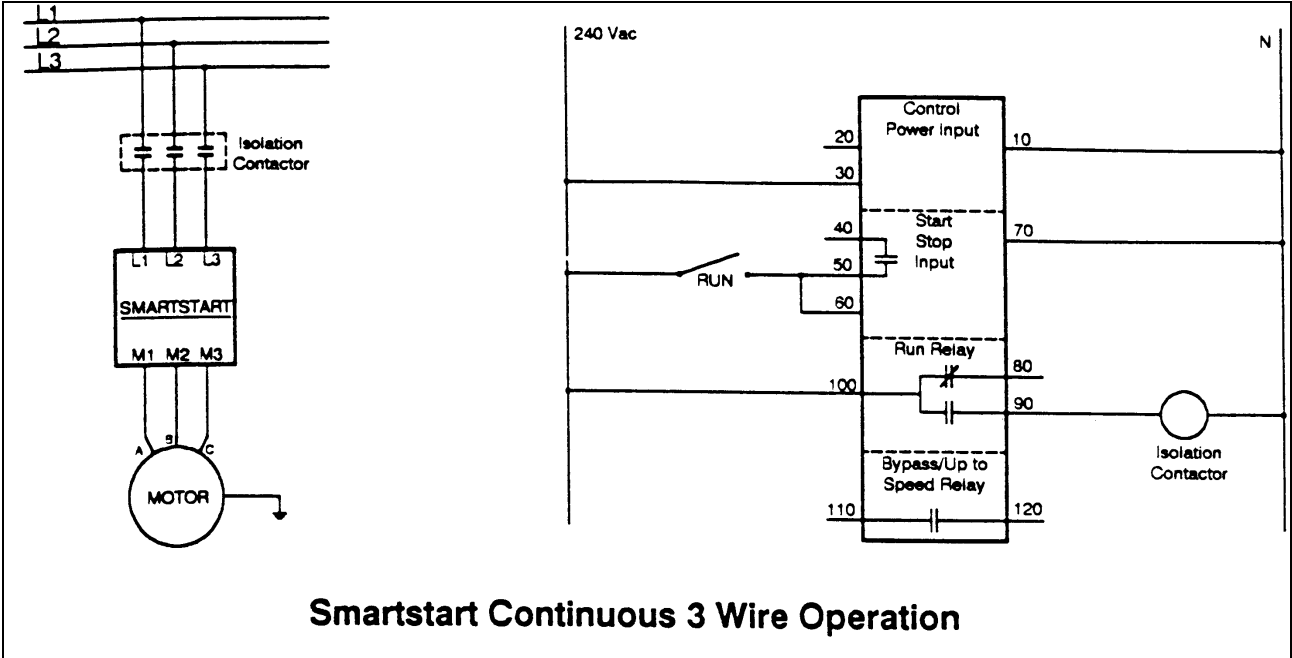

In continuous operation the Smartstart accelerates to full speed and runs under its own control. This is the easiest configuration to use and is suited to a broad range of applications.

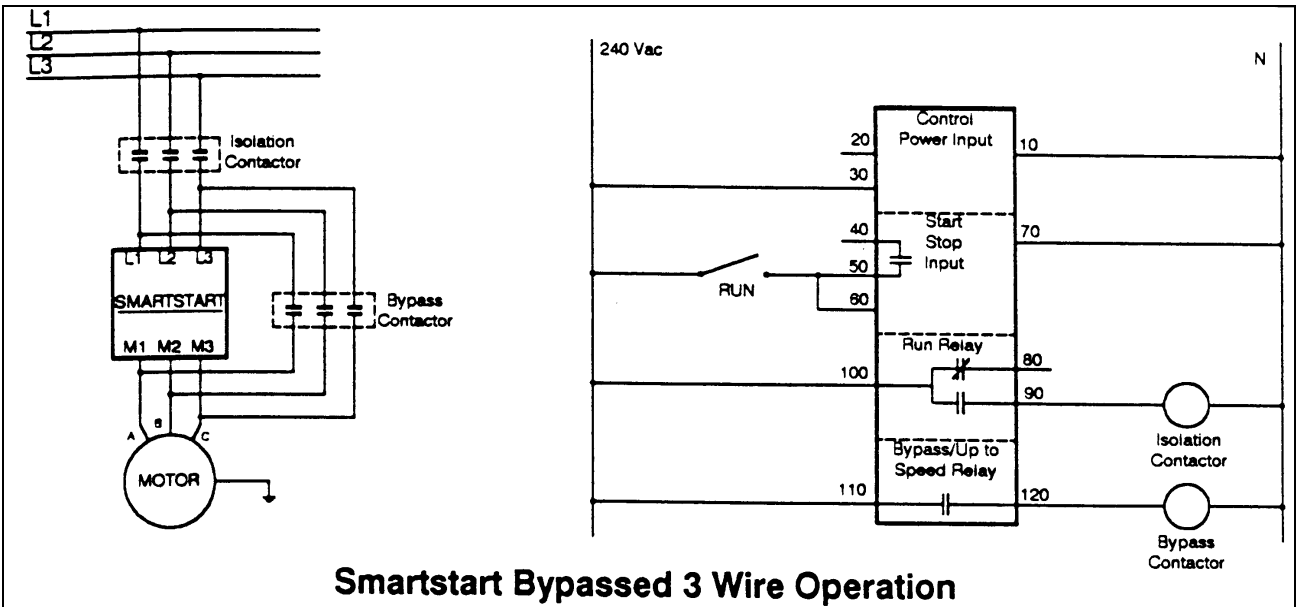

In the Bypass mode of operation the Smartstart accelerates the motor to full speed then switches a contactor to bypass thus removing it from the current path to the motor. This configuration results in much less heating of the Smartstart and thus is suited to applications where the available volume of cooling air is small.

POWER WIRING 6 Wire Connections

6 Wire connection of the Smartstart has the advantage that lower current flows through the Smartstart. The lower current through the Smartstart leads to lower heat losses. 6 Wire connections are also advantageous if the Smartstart is being used to retrofit an existing Star-Delta starter, where 6 motor wires are already present. In many cases it is possible to use a smaller size starter for 6 Wire connection than is possible for 3 Wire connection.

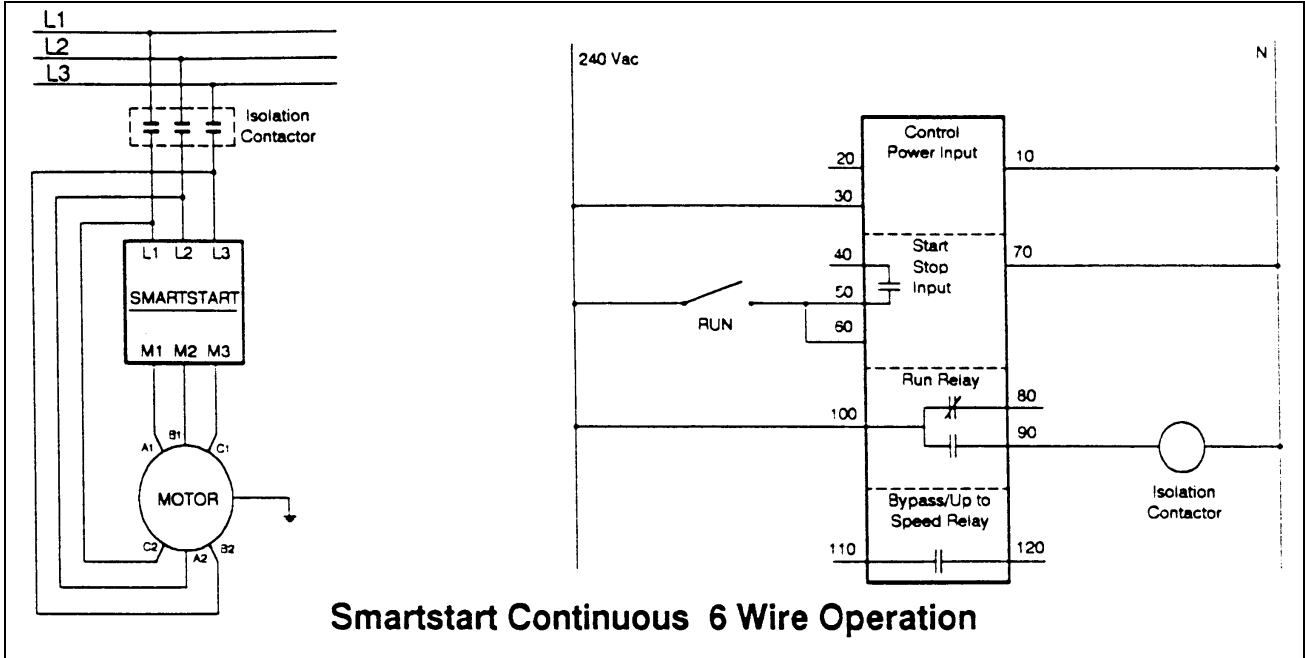

6 Wire continuous operation is similar to 3 Wire continuous operation but the advantage of using the 6 Wire configuration is that the actual current being switched by the Smartstart is significantly less than that of the 3 Wire case and in most instances a smaller Smartstart may be chosen.

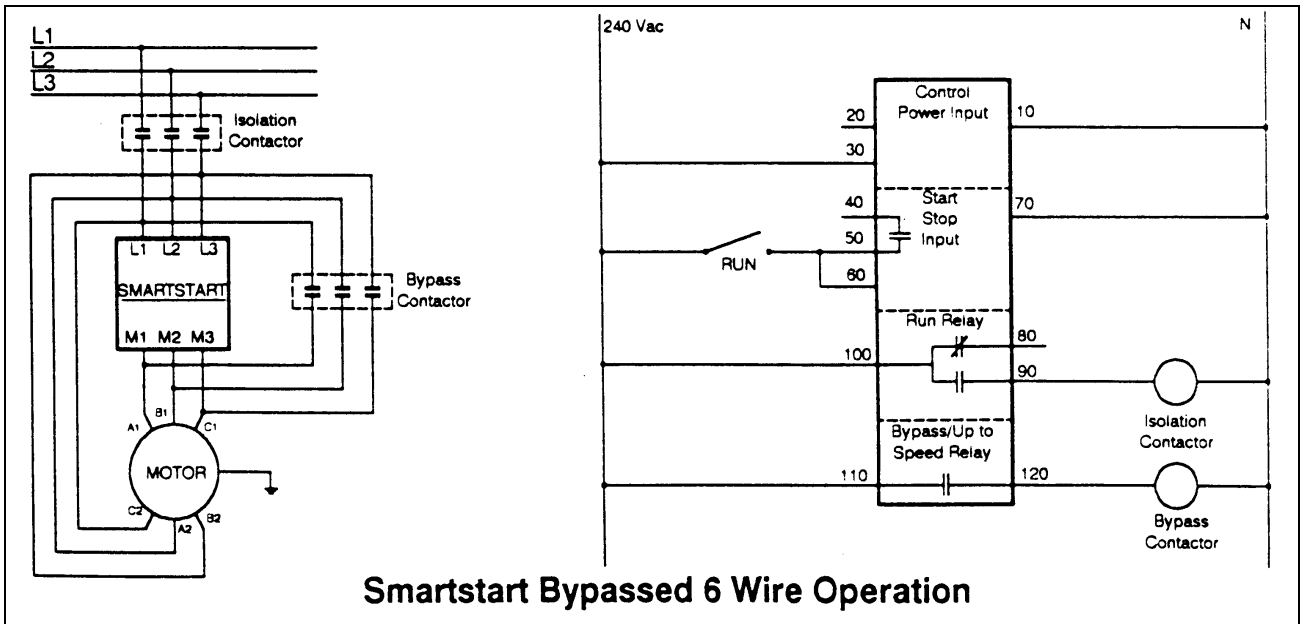

6 Wire bypassed operation differs from the 3 Wire bypassed connection because there is less current flowing through the Smartstart and thus a smaller bypass contactor may often be used.

CONTROL WIRING DIAGRAMS

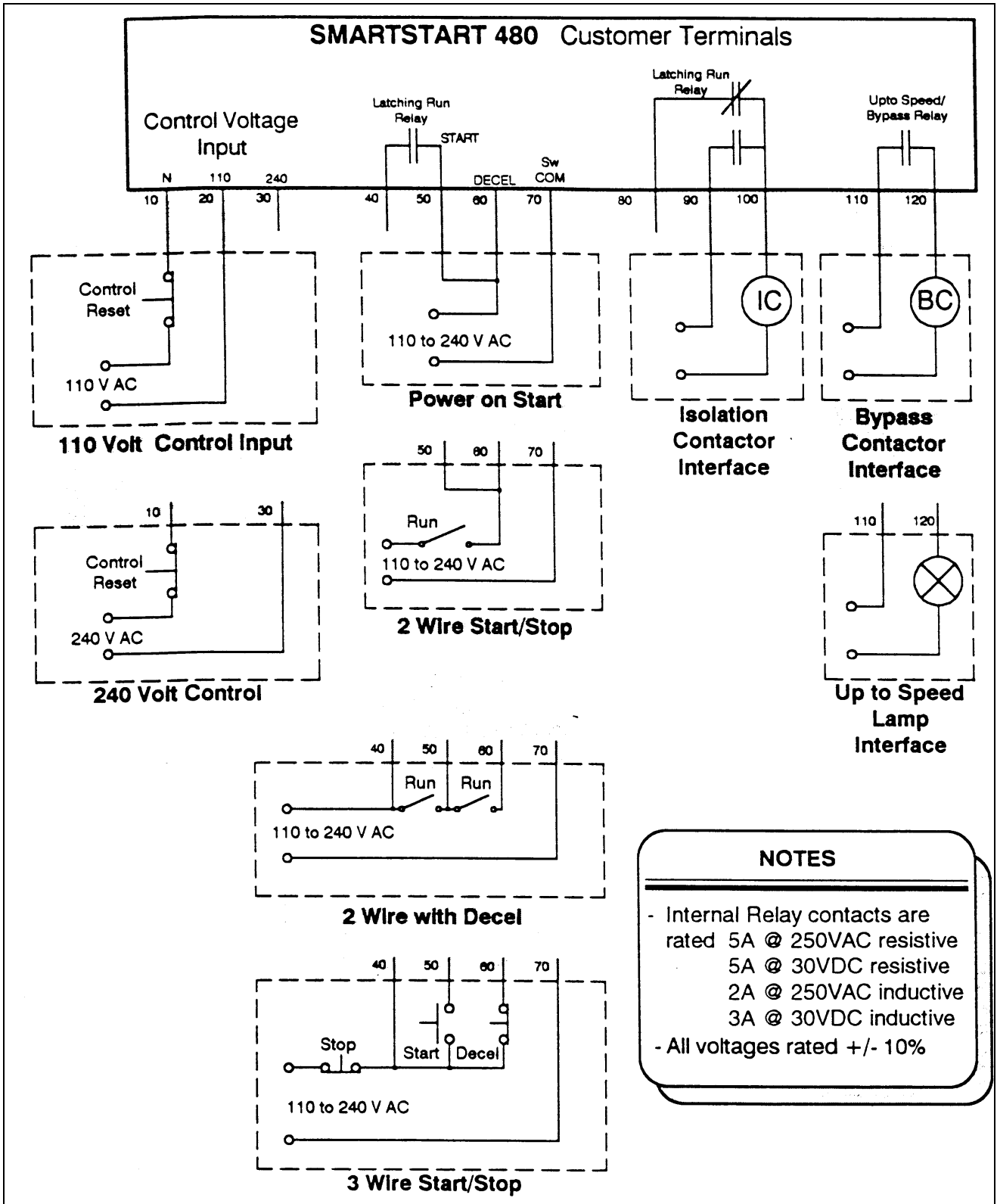

DIAGNOSTIC / STATUS INDICATION

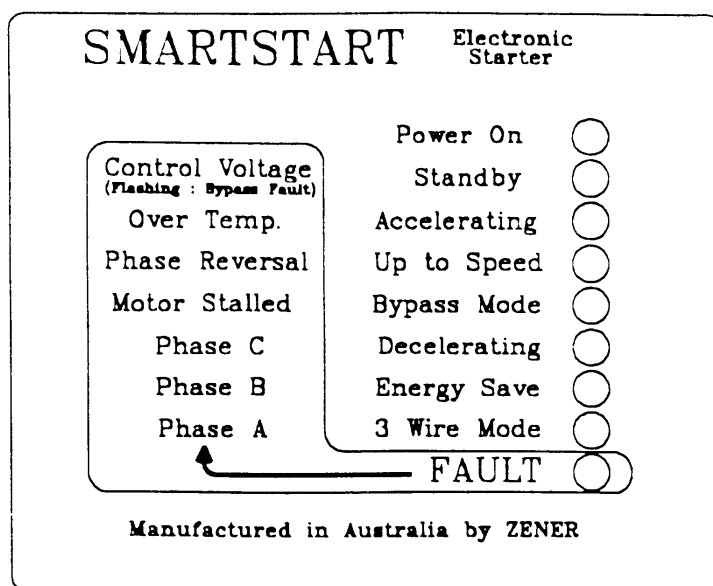

The diagnostic / status indicator shows either the current state of the Smartstart while running normally or indicates what fault caused the unit to stop. If the Smartstart tripped off the bottom red LED will illuminate along with a corresponding LED indicating the reason for tripping. The cause is determined by the left hand column of the indicator.

STATUS (normal operation)

CONTROL VOLTAGE

Indicates that the 100 or 240 VAC control voltage has been applied to the control circuit of the Smartstart.

STANDBY

A start signal has been received and the Smartstart is waiting for 3 phase power to be applied.

ACCELERATING

The starter is accelerating the motor to full speed.

BYPASS MODE

Acknowledges the operation of the bypass contactor and signals that the Smartstart has been successfully bypassed.

ENERGY SAVE

This LED illuminates when the energy save option has been enabled and motor voltage reduced, to save some energy in running the motor.

3 WIRE MODE

This LED indicates that the Smartstart is connected in the 3 Wire configuration, if this is not illuminated the Smartstart is connected in 6 Wire.

DIAGNOSTIC (with Fault LED)

CONTROL VOLTAGE

Failure due to low control voltage on the control PCB.

CONTROL VOLTAGE (flashing)

Bypass contactor failed to operate correctly.

OVER TEMP

The temperature of the heatsink assembly has reached its maximum allowable level, further operation may result in damage to SCR assemblies. Heatsinks must be allowed to cool before a restart is possible.

PHASE REVERSAL

The phase reverse inhibit option has been selected and an attempt has been made to start in the reverse direction, (Phase rotation CBA).

MOTOR STALLED

Motor stalled detection has been enabled and the motor has been overloaded to a point where a stall is imminent.

PHASE A,B or C

This will occur if a permanent fault occurs on a phase. A phase fault can either be in the Line input, Motor output or the SCR assembly.

PHASE A, B and C

This will occur if intermittent faults have occurred on one or more phases. To trip the Smartstart on a fault condition there must have been 4 faults in any 5 minute period.

SMARTSTART ADJUSTMENTS

GENERAL PARAMETERS

Switch SW-A is used to set the general operating parameters for the Smartstart. These parameters are checked by the Smartstart every time a start signal is given.

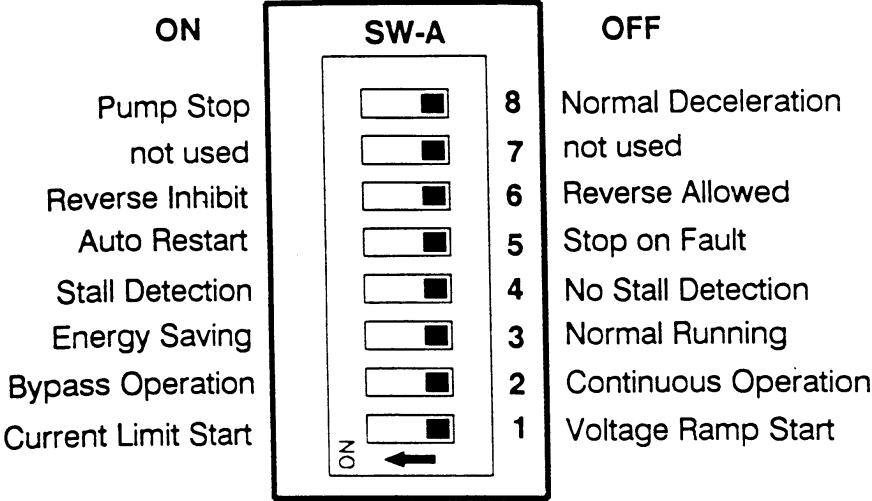

STARTING PARAMETERS

Two rotary switches((SW-C and SW-D) are used to set the starting parameters of the Smartstart. These switches are used to set the Acceleration time and the Breakaway level for the start.

Acceleration Time

The acceleration time is the time for the Smartstart to ramp the motor voltage from the breakaway level up to full line voltage. The time is adjusted using SW-C and is checked by the Smartstart every time a start signal is given. The times are as follows:

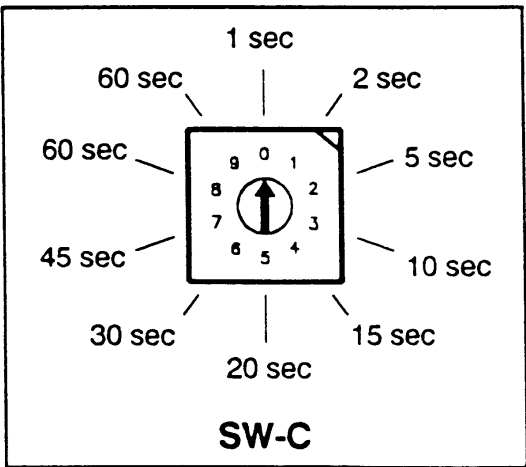

Breakaway Level

The breakaway level is used to adjust the starting voltage applied to the motor when the Smartstart receives a start signal. The voltage is ramped from the breakaway level to full voltage over the acceleration time. The breakaway level is checked by the Smartstart every time a start signal is given. The breakaway level is adjusted using SW-D and is given as a percentage of motor full load current as follows:

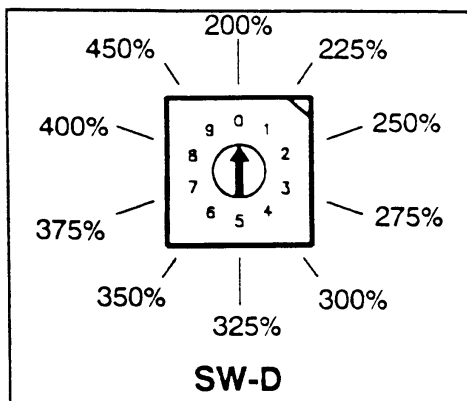

SWITCH B

Switch SW-B on the Smartstart control card is used to control the Deceleration multiplier and the Kick Start duration. The values set by this switch are checked by the Smartstart every time a start signal is given.

Deceleration Multiplier

Switches B1 and B2 are used to set the deceleration multiplier. This determines the time taken to ramp down the motor voltage when a decel signal is given. The deceleration time is calculated by multiplying the acceleration time by the multiplier set with switch SW-B.

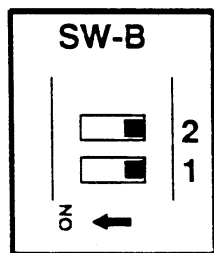

x 0.5

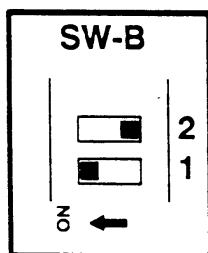

x 1

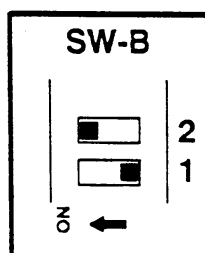

x 2

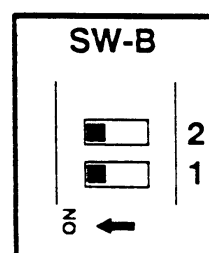

x 4

Kick Duration

Switches B3 and B4 are used to set the time that a kick voltage will be applied to the motor before beginning the normal acceleration ramp.

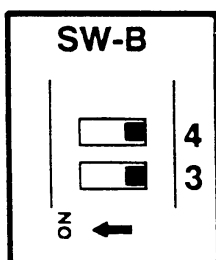

No Kick

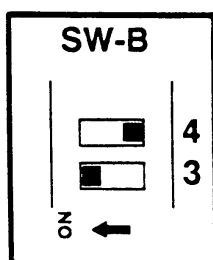

0.5 sec

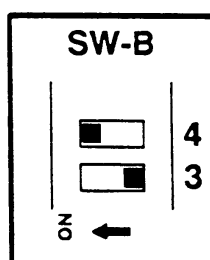

1 sec

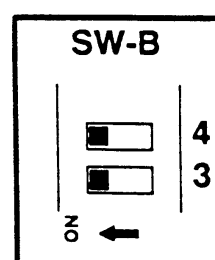

2 sec

SMARTSTART 480

STARTUP PROCEDURE

Before following this startup procedure ensure that the 3 phase supply and control supply to the Smartstart are disconnected.

CONTROL POWER

Switch the control power on to the Smartstart. The POWER ON LED on the status indicator should illuminate. If not, check the control power wiring to the Smartstart.

Give the Smartstart a signal to start the motor and STANDBY LED should illuminate. If not, check the wiring of the start stop signals to the Smartstart control terminal strip. When a stop signal is applied to the Smartstart the STANDBY LED should go out.

ACCELERATION TIME

Acceleration time is the time that the Smartstart will take to apply full voltage to the motor after the start signal is applied.

Using the Acceleration time control, SW-C, set the desired time for the motor and load combination to accelerate from rest to full speed. 10 or 15 seconds is usually a good selection for most loads, however for larger loads or high inertia loads longer acceleration times may be needed.

BREAKAWAY

The breakaway level is the voltage level that the voltage ramp will commence from after the application of a start signal.

Using the Breakaway level control SW-D, set a suitable breakaway level for the motor and load combination. 300% FLC is a good starting point for most loads, however for larger loads or loads with higher inertia a higher breakaway level may be required. Likewise for smaller or low inertia loads, a lower breakaway level may be required to provide a smooth start to the acceleration ramp.

KICK SELECTION

The kick selection feature is a method of applying near full voltage to the motor for a short period of time to break any static friction or “stiction” that may stop the load from accelerating smoothly from rest. If required, use the shortest kick setting to break the “stiction” of the load using SW-B/3 and SW-B/4.

DECELERATION MULTIPLIER

The deceleration multiplier sets the time that the Smartstart will take to reduce the voltage from full volts to no volts, thus providing the load with an extended stop characteristic. The time is set by multiplying the acceleration time by the setting of the deceleration multiplier.

If a soft stop is being used select the appropriate multiplier to set the desired soft stop time, using SW-B/1 and SW-B/2.

POWER ON

Connect the 3 phase supply to the unit or isolation contactor so that main power will be present when the start is performed. Connect the control voltage to the Smartstart. Apply a start signal to the Smartstart, the motor will begin to accelerate as indicated by the ACCELERATING LED on the status indicator. If the start is too harsh or too slow adjust the breakaway, acceleration time or kick duration to achieve the desired result.

SMARTSTART 480

OTHER FEATURES

CURRENT LIMIT

Current limit is used when it is necessary to limit the maximum current being applied to the motor during the acceleration ramp. It must be realised that a current limit setting that is too low may result in a stall condition if the motor torque is reduced to such a level that the load cannot be accelerated to its full speed. If this occurs then a large current surge will occur at the end of the acceleration ramp when the Smartstart applies full voltage to the motor. (Also see Stall Detection).

UP TO SPEED / BYPASS CONTACT

Terminals 100 and 110 of the Smartstart are an internal voltage free contact set that perform two functions. If the Smartstart is operating in a continuous mode the contacts close at the end of the acceleration indicating that full voltage is now being applied to the motor. If operating in bypass the contacts close at the end of the acceleration ramp and are used to switch a bypass contactor.

ENERGY SAVING

During times of light load or no load for the motor benefits can sometimes be obtained by reducing the voltage applied to the motor. This can result in some energy savings and a cooler running temperature for the motor. The energy savings in real terms are fairly minimal. The Smartstart self calibrates and automatically adjusts for all load conditions by improving the power factor. Energy saving does not operate while the starter is bypassed.

STALL DETECTION

The Smartstart monitors the motor load from the completion of the acceleration ramp until the Smartstart is stopped. If a stall or underspeed condition occurs the Smartstart will shut down with a STALLED fault. The stall detection does not operate while the unit is bypassed.

AUTO RESTART

This feature allows the Smartstart to attempt a sequence of 3 automatic restarts following fault conditions. This is especially useful in remote or unmanned installations. The unit will attempt 3 restarts within a five minute period, if the 3rd attempt is unsuccessful the Smartstart will trip with a permanent fault condition. The time taken to attempt a restart is 10 seconds after a fault.

PHASE ROTATION INHIBIT

The phase rotation inhibit feature will prevent the Smartstart starting loads in a reverse direction. When selected the Smartstart will only start loads with a phase sequence of A-B-C. This feature is especially useful for loads that must be limited to one direction of rotation only.

PUMP STOP

To get greater control over the stopping of pumps, thus reducing water hammer problems, the pump stop option may be used. This will allow tailoring of the deceleration ramp profile by adjusting the initial voltage drop point and the final cut off point for the deceleration ramp. This enables controlled deceleration over the pump's critical operating range. For further detail on using pump stop option refer to Appendix B of this manual.

ALTERNATIVE CONTROL VOLTAGE

An optional interface transformer available to allow control voltage to be supplied from differing voltages. Alternative voltages of 346, 380, 415, 440 Volts are possible with this interface transformer.

SMARTSTART 480

APPLICATION CONSIDERATIONS

CONTINUOUS OR BYPASS

Due to the nature of the SCRs used in the Smartstart power circuit, continuous running generates heat. The heat required to be dissipated is approx 1 to 1.5 Watts / Amps / Phase. This heat will play a significant role in the sizing of the enclosure. One method of overcoming this problem is to use a bypass contactor to bridge the Smartstart out once full motor voltage has been applied. This will reduce the generated heat to a level of about 20% of a continuously operating Smartstart.

ELECTRICAL NOISE

Severe cases of electromagnetic or other forms of electrical disturbances may cause erratic behaviour of the Smartstart. Zener recommends the fitting of RC snubbers across coils of any large relays or any contactors, which are operated from the same supply as the Smartstart.

ENCLOSURES

When mounting the Smartstart into an enclosure care must be taken to ensure the ambient temperature for the enclosure does not exceed 50 degrees Celsius. The size and/or the ventilation of the enclosure must ensure adequate dissipation of heat generated by the Smartstart. The heat generated is in the order of 1 to 1.5 Watts/Amp/Phase for continuous running or 20% of this figure for bypassed running.

MOTOR THERMAL PROTECTION

Motor thermal protection is not provided with the Smartstart and must be provided separately. Bimetallic or eutectic overload devices should be used with the Smartstart. Some early design of electronic thermal overloads may experience problems when being operated with electronic motor starters, and may lead to false overload conditions.

MOUNTING

The Smartstart is in an air cooled unit and thus it is important that the controller be located in a position which allows access to free air to flow through the controller. If operating the Smartstart in a continuous mode there should be at least 200mm clearance above and below the Smartstart for cooling air to flow.

OFF STATE ISOLATION

Although the SCR devices used to switch the supply in Smartstart are adequate to interrupt the motor supply, it is advisable (or even legally required) that an isolation contactor be used to isolate the supply to Smartstart when required, for safety reasons.

POWER FACTOR CORRECTION

If the electrical installation of the motor requires that power factor correction capacitors be fitted, they must be installed on the line side of the Smartstart. If the capacitors are connected at the same time that power is connected to the Smartstart ensure a delay (approx 1 sec) is allowed before a start signal is applied, this will allow any transients caused by switching the capacitors to decay before starting the motor.

PARALLEL MOTORS

If two or more identical motors are employed in such a way that each motor experiences the same simultaneous load change, then a single Smartstart may be used to start all motors at the same time. Care must be taken to ensure the combined or total full load current does not exceed the Smartstart ratings.

SLIP RING MOTORS

The Smartstart can usually be applied to slip ring motor applications. This is done using a single step rotor resistance in circuit on startup. At the end of the acceleration ramp the rotor resistance is shorted out.

SMARTSTART 480

SMARTSTART TROUBLESHOOTING

The following is a quick fault finding guide to follow if the Smartstart develops problems.

PROBLEM TYPE

POSSIBLE CAUSES

Motor Fails to Start

No control volts LED

Control Supply not present
Blown control fuse
Failed control card

Standby LED does not respond when start signal applied

Incorrect start / stop wiring
External interlock open
Failed control card

Standby LED on but not accelerating LED

3 phase line not connected
Motor not connected
Blown semiconductor fuse(s)

Overtemperature fault

Heatsink assembly too hot
Faulty temperature sensor
Excessive starting duty
Excessive running current
Inadequate ventilation

Other Fault Conditions

All phase fault LED on

Permanent phase fault on either line, motor or SCR assembly

Single phase fault LED on

Intermittent phase fault on either line, motor or SCR assembly

Motor fails to reach full speed then starts DOL

Current limit setting too low to get motor to full speed or acceleration ramp too short

If an SCR assembly is suspected of being faulty test as per SCR test procedure on page 14.

SMARTSTART 480

TESTING SCR ASSEMBLIES

In the unlikely event that the Smartstart SCR assembly must be tested, the following procedure should be followed.

All the SCR connections on the Smartstart are colour coded as follows:

LINE	Orange (with a White mate)
MOTOR	Blue (with a Yellow mate)

Each phase of the Smartstart should be checked in the following manner.

1. Remove the three SCR gate lead connectors from the control PCB assembly
2. Check the semiconductor fuses. If faulty, note which phases failed.
3. Using a 1000 DC megger check the isolation from line to motor in one direction (allow enough time for the meter reading to settle) then reverse the megger leads and check the reverse direction. The megger should give readings of between 5 and 10 Megohms in each direction. If excessive leakage or a short circuit is discovered the SCR is faulty. In this case one, two or both SCRs could be faulty. In the case of a Smartstart A80, A115 or A175 a spare SCR module will be required and in the case of a Smartstart A300, A450 or A650 a replacement power pole will be required.
4. Using a multimeter test the gate lead of each SCR. Use the resistance (or Ohms) scale on the multimeter to measure the resistance of each pair of wires in the gate lead, (Orange/White and Blue/Yellow). The gate leads should test a low resistance of between 10 and 40 Ohms. Reverse the meter leads and the same resistance should be observed. If the measurement is outside this range the SCR is faulty, and in the case of a Smartstart A80, A115 or A175 a spare SCR module will be required and in the case of a Smartstart A300, A450 or A650 a replacement power pole will be required.

NOTE: Power pole SCR assemblies are not user serviceable. Under no circumstances should the power pole be disassembled. Replacement power poles and exchange units are available from Zener distributors.

APPENDIX A

FUSE INFORMATION

The following table gives full details of the fuse characteristics for the Smartstart range, this may be helpful in sizing Smartstart applications.

Model	SCR I^2t	Zener fuse	Total I^2t	Fuse Time Current (Amps)		
				10s	30s	60s
A80	20,000	TF22200	19,800	360	310	280
A115	125,000	TF22400	108,500	840	670	615
A175	405,000	TF22400	108,500	840	670	615
A300	300,000	TF23630	252,00	1,320	1,060	970
A450	800,000	TF23500	648,00	2,100	1,680	1,540
A650	2,500,000	TF23700	1,468,00	2,940	2,350	2,200

APPENDIX B

Pump Stop Option

If the Smartstart is being used to control a pump, the pump stop option can be used to reduce water hammer problems that may occur if the pump was stopped conventionally or even with the Smartstart's standard extended stop function. By controlling the initial drop point of the Smartstart deceleration ramp and the final cut off point, it is possible to control the slowing down of the pump over its critical operating region.

This control is achieved by dropping the initial voltage to a level where the motor is still turning but a stall condition would result if voltage drop was reduced any further. The final cut off voltage should be set just below the pump stall point. In this way the slowing of the pump is performed for the set deceleration time and is only ramped over the critical operating region of the pump, which reduces water hammer problems in the system.

The standard deceleration characteristic of Smartstart is to drop the motor voltage from full line volts to an initial drop point then ramp the motor voltage down for the period of the deceleration ramp to bring the motor to a gradual stop. The ramp down time is set by multiplying the acceleration time by the deceleration multiplier.

The initial drop point is set using rotary DIP switch SW-F where position 0 is the smallest drop and position 9 is the largest drop available. The final cut off point is set using rotary switch SW-E where position 0 is the lowest available cut off point and position 9 is the highest available cut off point.

For Example: To set up the Smartstart with the biggest initial voltage drop and the highest final cut off point use SW-F = 9 and SW-E = 9. To set the biggest initial drop and the lowest final cut off point use SW-F = 9 and SW-E = 0. The following diagram indicates the curve shape and the switch actions.

If you are unsure, start with the smallest initial drop (SW-F = 0) and the lowest cut off point (SW-E = 0) and adjust firstly the initial drop voltage to a point where the motor almost stalls, then adjust the final cut off point to be as high as possible and still stall the motor.

Smartstart Voltage Profile

