

## Table of Contents

Section	Page
Scope	1
Receiving	1
Product Warranty	2
1.0 AMC-2000 Selection	3
2.0 AMC-2000 Technical Specifications	4
3.0 Mechanical Installation Diagram	5
4.0 Electrical Installation Diagrams	
4.1 Power on start I	6
4.2 Power on start II	7
4.3 Remote Enable Start	8
5.0 Relay Output	
5.1 Run Relay	9
5.2 Latching Fault Relay	9
5.3 Hold Circuit / Relay	9
6.0 AMC-2000 Display	10
7.0 AMC-2000 User Interface	
7.1 Run / Setup Switch	10
7.2 Parameter Access	10
8.0 Adjustment Procedure	11
9.0 Fault Description	15
10.0 Motor Overload Protection	16
11.0 Semiconductor Fuses	18
12.0 Your AMC2000 Setup notes	19

### Scope

This document is a guide for the installation and operation of the AMC-2000 Motor Mate Soft Starter. It contains essential information to complete the task. All warnings and recommendations should be followed, and in case of uncertainty, please contact Zener Electric for written clarification if necessary. This manual supports the AMC-2000 from software version 1.11.

### Receiving

Inspect the AMC-2000 for shipping damage. If any damage is found report it to the carrier immediately. Do not attempt to operate the AMC-2000 if any obvious damage exists.

**THE CONTENTS OF THIS MANUAL ARE SUBJECT TO CHANGE WITHOUT NOTICE**

## AMC2000 Product Warranty

Zener Electric (Newcastle) warrant the AMC-2000 against defective workmanship and materials for a period of 24 months from the date of despatch. Such defects will be rectified free of charge for both labour and material, at Zener Electric premises subject to:

1. Zener Electric (Newcastle)'s customer raising an order upon Zener for service and/or repairs, subject to a warranty claim. The order is to state particulars of the model and serial number, the date of original purchase and invoice/delivery docket number.
2. All damage resulting from incorrect installation or use other than in accordance with the instruction manuals issued by Zener Electric (Newcastle) is excluded from this warranty.
3. The warranty being rendered invalid if the product is misused or if any unauthorised alteration, modification or substitution of any part of the product be made or the serial number of the product is defaced or altered.
4. The cost of transportation (both ways) is to be met by the owner if it is necessary to return the product, or any part of it, to Zener Electric (Newcastle)'s premises.
5. A charge being accepted by the owner for travelling time and expenses incurred in connection with warranty service at the user's site as requested by the owner.
6. If the product was not purchased from Zener Electric (Newcastle) directly, then a warranty claim must be lodged with the original supplier in the first instance. Repairs will not be effected by Zener Electric (Newcastle) unless approved by the original supplier. Goods not of our own manufacture incorporated in our supply or sold by us, carry their makers warranty.
7. Goods returned for claim under warranty will be accepted on the condition that should the claim be rejected than all costs, including inspection, will be charged to the customer's account.
8. Zener Electric (Newcastle) is not liable for any consequential loss

## Safety

Your AMC-2000 must be applied, installed and operated in a safe manner. It is the responsibility of the user to ensure compliance with all regulations and practices covering the installation and wiring of your AMC-2000. The instruction manual should be completely read and understood before attempting to connect or operate the AMC-2000. Only Skilled personnel should install this equipment.

**1.0 AMC-2000 Selection**

The AMC-2000 is designed for starting medium duty loads. Medium duty applications are those that require low starting current (<300%) for a short period of time (<30 seconds). Typical examples include centrifugal pumps, unloaded compressors and other low inertia loads. The following table allows selection of the AMC-2000 for medium duty applications. Ensure the motor voltage, current ratings remain within the limits stated for the AMC-2000.

Voltage	Motor Rating kW *	AMC-2000 rating Amps	Model
380-415	7.5kW	15A	AMC-2000-A15
	15kW	30A	AMC-2000-A30
	30kW	60A	AMC-2000-A60
	45kW	80A	AMC-2000-A80
220-240	4.0kW	15A	AMC-2000-L15
	7.5kW	30A	AMC-2000-L30
	15kW	60A	AMC-2000-L60
	22kW	80A	AMC-2000-L80

\*Nominal KW at specified voltage

**Heavy Duty Applications:**

Heavy duty applications such as conveyors and other high inertia loads may require high starting currents and extended ramp times. In these applications the AMC-2000 may require derating. Please consult your AMC-2000 distributor for further information.

**High Ambient temperatures:**

The AMC-2000 is rated for an ambient temperature of 45°C. The AMC-2000 may operate above this temperature with suitable derating. Please consult your AMC-2000 distributor for further information.

## 2.0 AMC-2000 Technical Specifications

### General

Input voltage	AMC-2000 A: 380 - 415vac (50Hz) AMC-2000 L: 220 - 240vac (50Hz),
Input frequency:	50/60Hz +/- 3Hz auto detect
SCR PIV rating:	1400V
SCR configuration:	Fullwave
Duty:	300% of unit rating for first 15s, tapering to 100% at 30 s
Starts/hour:	10
Current rating:	15A, 30A, 60A, 80A
Mass: kg (lb)	4kg (8.8), 5kg (11.0), 6kg (13.2), 7kg (15.4)
Control supply:	Nil required
Environmental ratings:	0 to 45°C operating, -20 to 60°C storage 0% to 95% non condensing
IP rating:	IP20
Dimensions:	refer to page 5

### Protection:

Motor overload (Class 20, 10, 10a)  
 SCR over temperature  
 Under current (adjustable)  
 Over current (adjustable)  
 Motor stalled (300% for 3s)  
 Current limit (adjustable)  
 Softstarter Overload (Auto current limit)  
 Short circuit (Optional semiconductor fuses)  
 Phase loss / imbalance \*\*  
 Bypass fail  
 SCR fail  
 Control fail

### Features:

Voltage dip ride through  
 Integral bypass contactor  
 Fault Memory  
 Non volatile memory  
 Display  
 Intelligent Pumpstop



\*\* The Phase Loss/Imbalance feature provides protection only on the output of the SoftStarter.

### 3.0 Mechanical Installation Diagram

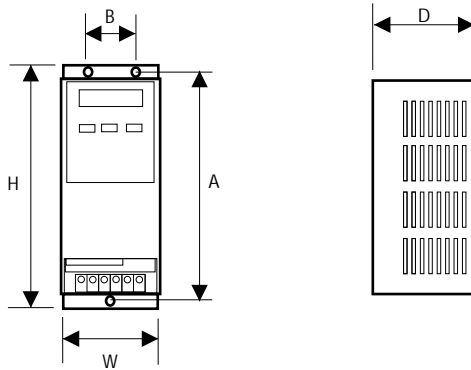

Model	Dimensions in mm (in)					Weight kg (lb)
	H	W	D	A	B	
AMC-2000 A15	340 (13.4)	100 (3.9)	162 (6.4)	310 (12.2)	60 (2.4)	4kg (8.8)
AMC-2000 A30	340 (13.4)	100 (3.9)	162 (6.4)	310 (12.2)	60 (2.4)	5kg (11.0)
AMC-2000 A60	405 (15.9)	100 (3.9)	180 (7.1)	375 (14.7)	60 (2.4)	6kg (13.2)
AMC-2000 A80	460 (18.1)	126 (5.0)	180 (7.1)	429 (16.8)	86 (3.4)	7kg (15.4)

#### Important

1. All dimensions are in millimetres.
2. Mount with M5 screws.
3. Do not allow metal shavings or any other conductive material to enter the AMC-2000 or damage may result.
4. The AMC-2000 must be mounted in a vibration free location.
5. Protect the AMC-2000 against dust build-up and dripping or sprayed liquids.
6. Operation temperature range: 0 to 45°C (32 to 113°F).

### 4.0 Electrical Wiring Diagrams

#### 4.1 Power on Start I (Soft Start only)

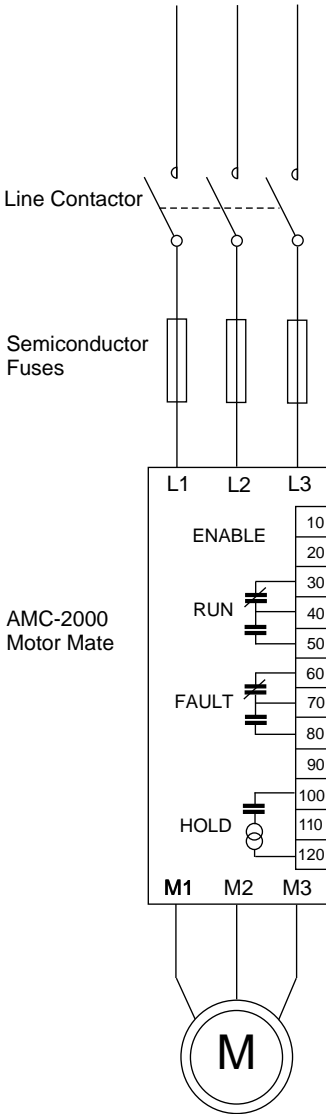

#### Description:

The AMC-2000 is controlled by the line contactor. A link installed between terminals 10 & 20 (Enable) means the AMC-2000 will start the motor when the line contactor is closed.

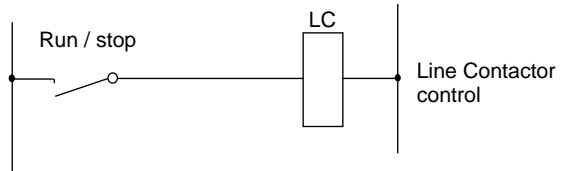

OR

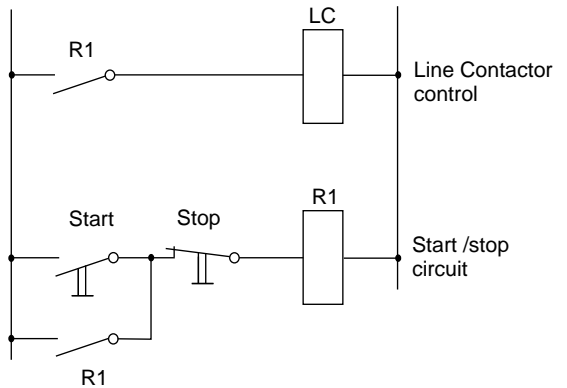

### 4.2 Power on Start II (Soft Start / Soft Stop)

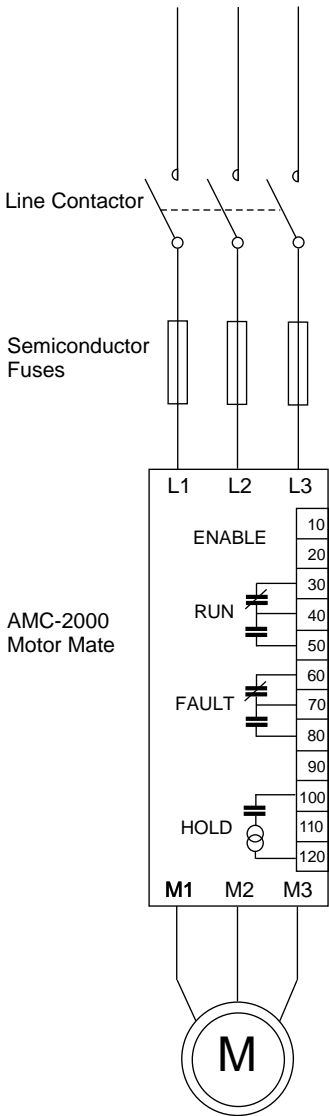

**Description:**

The AMC-2000 is controlled by the line contactor. A link installed between terminals 10 & 20 (Enable) means the AMC-2000 will start the motor when the line contactor is closed.

The Hold circuit acts as a latching relay for the line contactor. This maintains power to the AMC-2000 until the soft stop is complete. The AMC-2000 will then drop out the line contactor, ready for the next start.

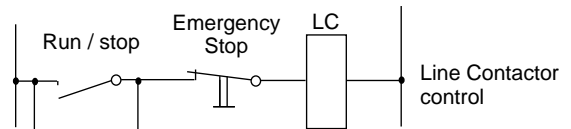

**Hold Circuit:**

The Hold circuit consists of a relay contact and a current sensing circuit. With the run/stop contact closed the current through the hold circuit is zero.

The AMC-2000 detects when the run/stop contact is opened by measuring the circuit current of the line contactor coil. When a current is detected, the AMC-2000 commences a soft stop. Once the ramp down is complete the Hold relay is de-energised which drops out the line contactor.

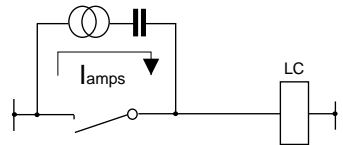

### 4.3 Remote Enable Start (Softstart / Softstop)

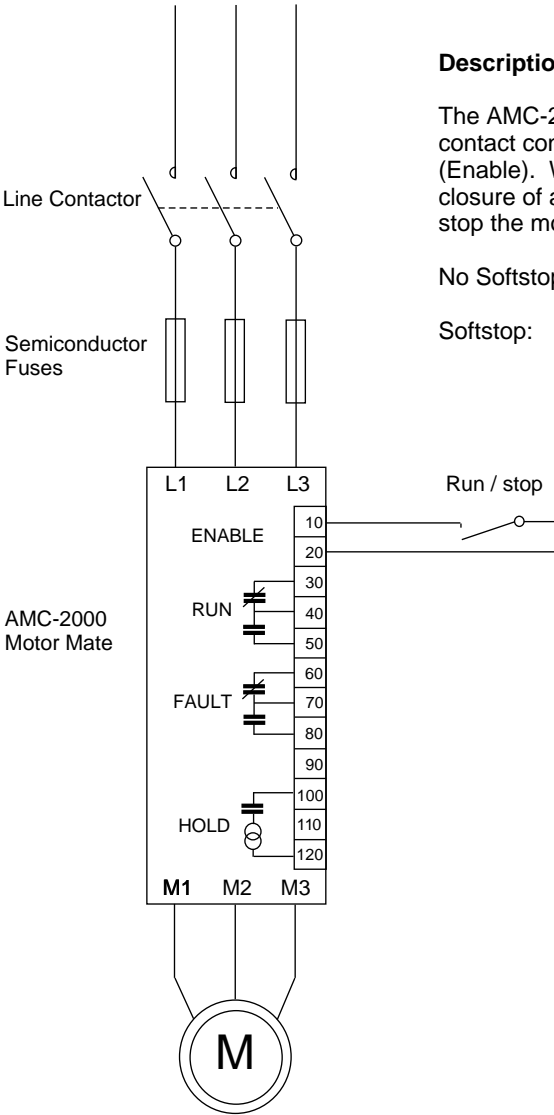

**Description:**

The AMC-2000 is controlled by a voltage free contact connected across terminals 10 & 20 (Enable). With power applied to L1, L2 & L3 the closure of a contact on the enable will start and stop the motor.

No Softstop: Set the Ramp down time to zero

Softstop: Set the desired ramp down time to give the desired soft stop.

## 5.0 Relay Outputs

### 5.1 Run Relay

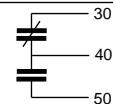
Run Relay	Power off	Power On Not enabled	Power On * Enabled
	Closed	Closed	Open
	Open	Open	Closed

\* Enabled = run/setup in 'run' and link 10/20 and no fault

### 5.2 Latching Fault Relay

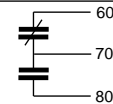
Fault Relay	No Fault	Fault
	Closed	Open (latched)
	Open	Closed (latched)

\* Fault cleared by resetting (refer to page 13). Removing power does not reset fault.

### 5.3 Hold Circuit / Relay

Refer to page 7 for connection diagram.

The Hold circuit consists of a relay contact and a current sensing circuit. With the run/stop contact closed the current through the hold circuit is zero.

The AMC-2000 detects when the run/stop contact is opened by measuring the circuit current of the line contactor coil. When a current is detected, the AMC-2000 commences a soft stop. Once the ramp down is complete the Hold relay is de-energised which drops out the line contactor.

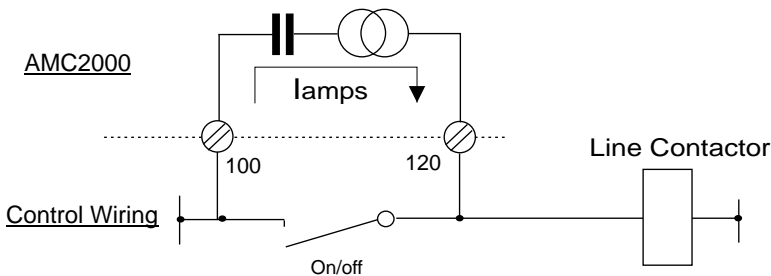

## 6.0 AMC-2000 Display

Supply frequency is indicated by;  
 50Hz = \*  
 60Hz = #

Status / fault displayed in plain text

Motor current displayed in Amps



Bar graph to provide visual indication of load

Motor current displayed as a percentage of motor FLC

## 7.0 AMC-2000 user interface

### 7.1 Run / Setup Switch

To change the operating parameters of the Softstarter, the Run / Setup Switch must be switched to Setup. If the Motor is running, changing the position of this switch will stop the motor.

**Warning: When the switch position is moved to run and if the Starter is enabled, the motor will start immediately.**

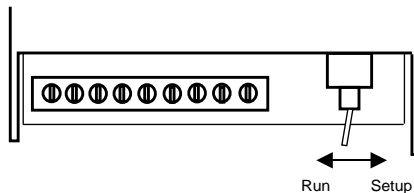

### 7.2 Parameter Access

There are 3 push buttons located on the front panel for adjusting the AMC-2000 operating parameters to achieve the desired motor start. These buttons have the following functions;

NEXT Press the Next button to scroll through the menu screens.

△ "Up" Increases the parameter associated with the current menu screen. The parameter can only be adjusted if setup mode is selected with the run / setup switch.

▽ "Down" Decreases the parameter associated with the current menu screen. The parameter can only be adjusted if setup mode is selected with the run / setup switch.

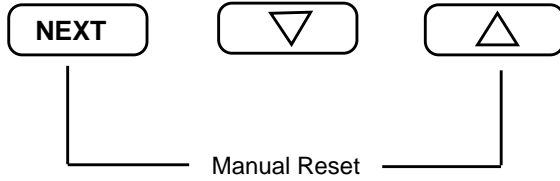

**Manual Reset** If the AMC-2000 has detected a fault condition, the unit can be manually reset by holding down the next and up pushbuttons simultaneously for 3 seconds. The AMC-2000 will "beep" and reset the fault.

**Warning: If the unit is enabled, the motor will start immediately upon resetting**

### 8.0 Adjustment Procedure

Adjustments are made by:

- 1.Setting the run/setup switch to setup.
- 2.Press "next" to scroll through the menu.
- 3.Press "up" or "down" to increase or decrease the value

<<Next>>

#### Unit Rating:

This first screen identifies the software version and the unit rating.

<<Next>>

#### Motor Rated Amps:

Adjust this value to the motor nameplate full load current. This is essential to ensure the correct operation of the overload protection and current limit.

Range: 5A to unit rating

Default: Maximum rating of unit (15A, 30A, 60A, 80A)

<<Next>>

#### Initial Torque:

Adjust to the lowest setting which allows the motor to turn on a start command. This is entered as a percentage of Locked Rotor Torque. This setting is dependant upon the load on the motor. Generally a pump will require a low setting, and a conveyor type load will require a higher setting. The lower this setting the softer the start.

Range: 10% to 25%

Default: 10%

&lt;&lt;Next&gt;&gt;

**Ramp up time:**

Adjust this to vary the time the starter takes to ramp the voltage to full supply voltage.

Range: 3 to 60 seconds  
Default: 10 seconds

&lt;&lt;Next&gt;&gt;

**Ramp down time:**

Adjust this to vary the length of the ramp down. The ramp profile can be selected to be either a linear ramp or an intelligent pump stop.

For a coast to stop set the Ramp down time to Zero.

Range: 0 to 120 seconds  
Default: 0 seconds

Refer to page 7 for wiring configuration for a soft stop with power-up start-up control.

&lt;&lt;Next&gt;&gt;

**Current Limit:**

Adjust to limit the starting current drawn by the motor. This may be used to limit current drawn from the supply or for a current limit start. Current limit starts may improve the soft starting of high inertia fans. This is a percentage of the motor full load current as entered.

Range: 200% to 500%  
Default: 300%

Note: The AMC-2000 has built-in SCR thermal protection to prevent damage due to undersizing or excessive starts/hour. This will further reduce the current limit where necessary to protect the SCRs. This is achieved by reducing the current limit automatically.

&lt;&lt;Next&gt;&gt;

**Fault Reset**

When the Softstarter detects a fault condition, the motor is stopped and the fault displayed on the LCD in plain English. The AMC-2000 provides a latching fault relay (terminals 60,70 & 80), which maintains it's status even if power is removed. There are three reset modes available; Manual, Remote or Automatic. These are explained below.

**Manual:**

The unit is reset by pushing the "next" and "up" simultaneously for 3 seconds. This resets the Soft Starter fault. If the starter is enabled it will start immediately without warning.

**Remote:**

The unit is reset by removing power or removing the enable signal (terminal 10 & 20). The fault relay will maintain it's status until power or the enable signal is reapplied. The AMC-2000 will then reset and start the motor. The manual reset function will also operate in this mode.

**Automatic:**

The unit will automatically restart after 60 seconds. Three attempts will be made at restart before flagging a permanent fault. The remote and manual reset function will also operate in this mode.

**Important**

If the AMC-2000 has tripped on Overload, the unit will not reset until the "motor temp" has fallen below 90%.

**Warning: If the unit is enabled, the motor will start immediately upon resetting**

**<<Next>> Under Current**

The AMC-2000 continually monitors the motor current. Under current protection can be enabled or disabled. Under current protection is only active while in bypass. If an under current condition occurs the fault relay is energised and the motor is stopped. The words "Under Current" are displayed on the LCD display until the AMC-2000 has been reset.

<<Next>> Trip level: 10% to 90% (default 10%)

<<Next>> Trip delay: 0 to 90 seconds (default 10 seconds)

**<<Next>> Over Current**

The AMC-2000 continually monitors the motor current. Over current protection can be enabled or disabled. Over current protection is only active while in bypass. So it ignores the high starting current associated with starting a motor. If an over current condition occurs the fault relay is energised and the motor is stopped. The words "Over Current" are displayed on the LCD display until the AMC-2000 has been reset.

<<Next>> Trip level: 100% to 250% (default 100%)

<<Next>> Trip delay: 0 to 10 seconds (default 10 seconds)

**<<Next>> Pumpstop**

The pumpstop provides an intelligent softstop for pumping applications. This feature can be enabled or disabled (default enabled). When the pump stop feature is enabled the AMC-2000 provides closed loop control of the ramp profile, to assist in the reduction of water hammer. The pump stop algorithm, under some conditions, may complete the ramp faster than the ramp down time setting.

**<<Next>> Motor Temperature**

This screen displays the motor thermal capacity used. The AMC-2000 will trip when this value exceeds 115%. The AMC-2000 will not allow a reset until this value falls below 90%, thus ensuring the motor has adequately cooled. The overload is factory set to class 10. The overload class can be adjusted with link settings on page 18.

**<<Next>> Return to Operating Screen**

This concludes the setup of the AMC-2000. Switch to "Run" and the AMC-2000 is ready to start. If the unit is enabled it will start without warning. You may need to further adjust the starting parameters to fine tune the starting of the motor.

## 9.0 Fault Description

The AMC-2000 has a backlit LCD to display fault messages in plain English.

When a fault is detected the AMC-2000 will stop the motor and sound an alarm. The display's backlight will flash and the fault message will be displayed until the AMC-2000 is reset. Refer to page 13 for instructions on resetting the AMC-2000.

\* Fault  
Bypass Failure

- If the AMC-2000 detects a failure of the bypass contactor, the SCRs commence firing. After 20 seconds, if the bypass failure still exists the AMC-2000 will stop the motor and trip on "Bypass Fault"

\* Fault  
Frequency Range

- The AMC-2000 will operate on either 50Hz or 60Hz supply automatically. If the supply frequency is +/-3Hz the AMC-2000 will not operate and trip on a "Frequency Fault"..

\* Fault  
Internal Fault

- An "internal fault" indicates a problem with the AMC-2000 control and should be returned to Zener for service.

\* Fault  
Motor Stall

- The AMC-2000 will trip on "Motor Stalled" when the motor current exceeds 300% of the entered motor FLC for 3 seconds.

\* Fault  
Motor Overload

- The AMC-2000 constantly monitors the motor current and provides motor overload protection. When the simulated motor temperature exceeds 115% the AMC-2000 will stop the motor and trip on "motor overload". Refer to page 16 for more details on the motor overload.

\* Fault  
Overcurrent

- Over Current fault is selectable, and provides protection of the load/application by monitoring the motor current. Refer to page 14 for more details on this feature.

\* Fault  
Phase Loss/Imbal

- The AMC-2000 will detect a short circuit SCR. It will also detect an open circuit, short circuit or imbalance in the motor power wiring.

\* Fault  
Undercurrent

- Under Current fault is selectable, and provides protection of the load / application by monitoring the motor current. Refer to page 14 for more details on this feature.

### 9.0 Fault Description (cont'd)

\* Fault  
Unit Over Temp

- The AMC-2000 will trip on "over temperature" with excessive starting, excessive starting current or high ambient temperature. The AMC-2000 also offers a built in protection mechanism to reduce the current limit when high temperatures are detected.

### 10.0 Motor Overload Protection

The AMC-2000 offers a motor overload of type R1, class 20, 10, 10a with a total memory function. The class of the overload can be modified to suit the motor supplier's recommendations. The factory setting of the motor overload is class 10, which is suitable for most applications. The protection offered by each class is illustrated in the graph below.

AMC-2000 TOL Characteristic (Class 20)

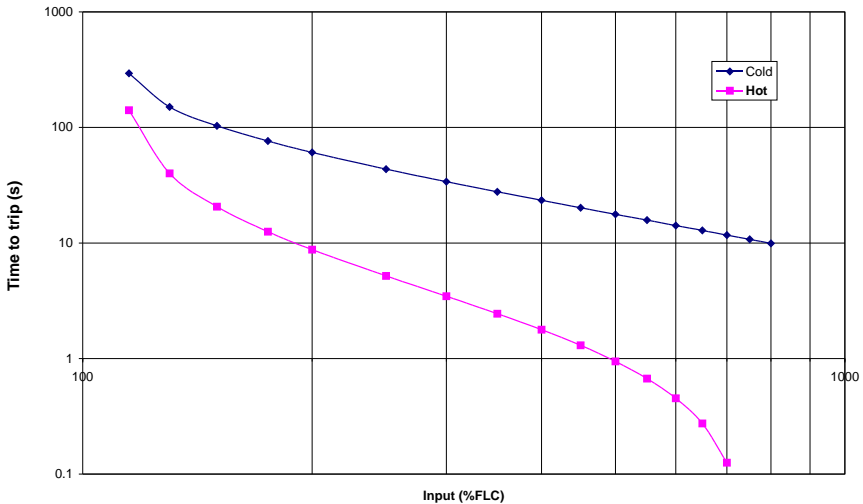

AMC-2000 TOL Characteristic (Class 10)

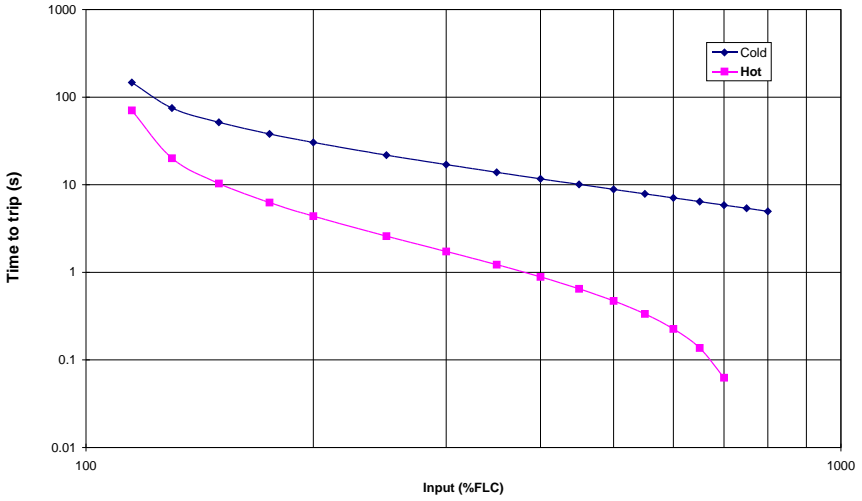

AMC-2000 TOL Characteristic (Class 10A)

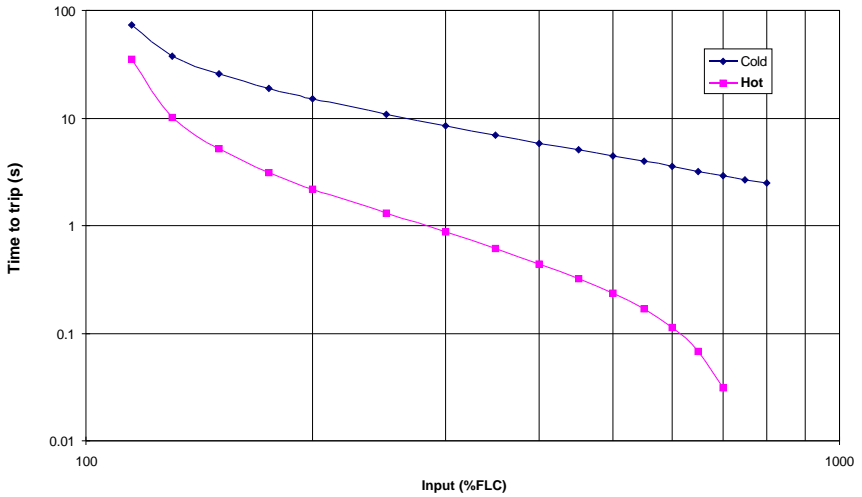

To change the overload class follow the procedure below:

1. Remove the right side panel, by removing the 4 screws. The AMC-2000 A60 and A80 both have fans and care must be taken not to damage the cables or connectors.
2. Locate the links on the right hand side, under the top PCB. Configure the links for the desired overload class as shown below.

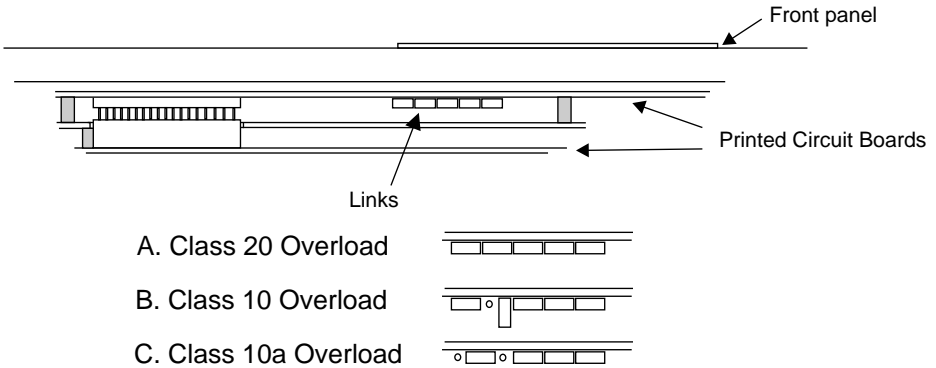

### 11.0 Semiconductor Fuses

Zener Electric recommends the installation of fast acting semiconductor fuses co-ordinated with the SCR's for short circuit protection of the SCR's. Semiconductor fuses are installed on the line side of the AMC-2000 as shown in the electrical wiring diagrams (pages 6-8).

Zener Electric offer fuse kit's consisting of suitable semiconductor fuses and associated mounting hardware. The table below is a guide for selecting the correct semiconductor fuse for the AMC-2000.

AMC-2000	Fuse Rating (Amps)	Maximum I <sup>2</sup> T (A <sup>2</sup> s)	Fuse Part No.	Fuse kit Part No.
AMC-2000 A15	32A	500A <sup>2</sup> s	TF20032	TQ00004
AMC-2000 A30	50A	1,000A <sup>2</sup> s	TF20050	TQ00005
AMC-2000 A60	100A	15,000A <sup>2</sup> s	TF20100	TQ00007
AMC-2000 A80	160A	25,000A <sup>2</sup> s	TF20160	TQ00008

### 12.0 Your AMC2000 Set-up notes

**Starter Designator:** .....

**Equipment Details:**

Model Number: .....

Serial Number: .....

**User Parameters:**

Date:.....

Motor Rated Amps:	.....	default:	Unit rating 15A, 30A, 60A, 80A
		range:	5A to unit rating
Initial Torque:	.....	default:	10%
		range:	10% to 25%
Ramp up time:	.....	default:	10 seconds
		range:	3 to 60 seconds
Ramp down time:	.....	default:	0 seconds
		range:	0 to 120 seconds
Current Limit:	.....	default:	300%
		range:	200% to 500%
Fault Reset:	.....	default:	Manual
		selection:	Manual / Automatic / Remote
Under Current:	.....	default:	disable
		selection:	enable / disable
Trip Level:	.....	default:	10%
		range:	10% to 90%
Trip Delay:	.....	default:	10 seconds
		range:	0 to 90 seconds
Over Current:	.....	default:	disable
		selection:	enable / disable
Trip Level:	.....	default:	100%
		range:	100% to 250%
Trip Delay:	.....	default:	10 seconds
		range:	0 to 10 seconds
Pump Stop:	.....	default:	disable
		selection:	enable / disable
Motor Overload:	.....	default:	Class 10
		selection:	Class 10a / 10 / 20

## **ZENER ELECTRIC (NEWCASTLE) PTY LIMITED**

ACN: 002 307 324

### ***Australian Manufacturers of Variable Speed Drives and SoftStarters***

Delivery Address:

1 William Street  
WICKHAM  
NSW 2293  
AUSTRALIA

Contact:

Tel: +61-2 - 4969 6788  
Fax: +61-2 - 4962 1451

Email: [welcome@zener.com.au](mailto:welcome@zener.com.au)  
Web Site: <http://www.zener.net>