

# PULL - SAFE

P/N: PS - P

## INSTALLATION & SETTING INSTRUCTIONS

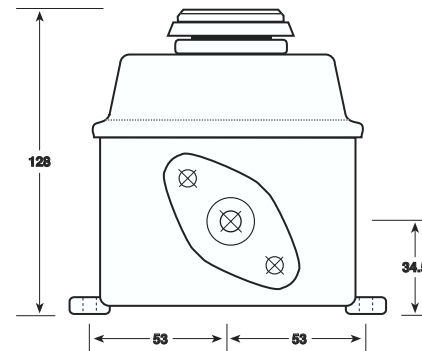
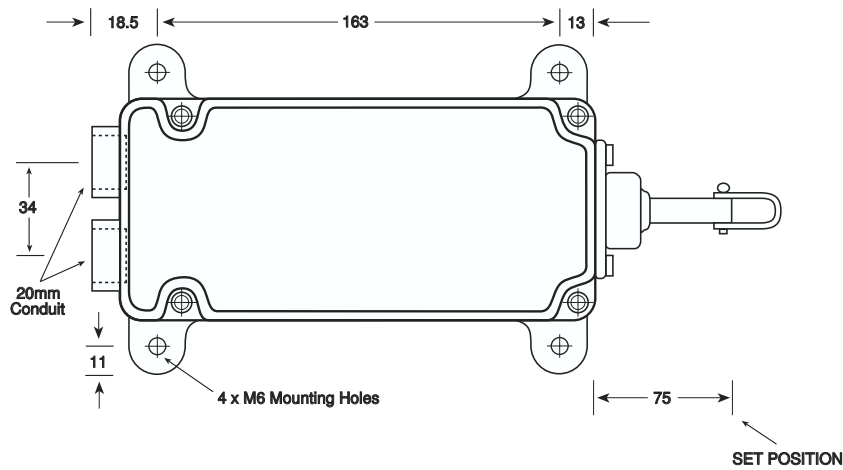
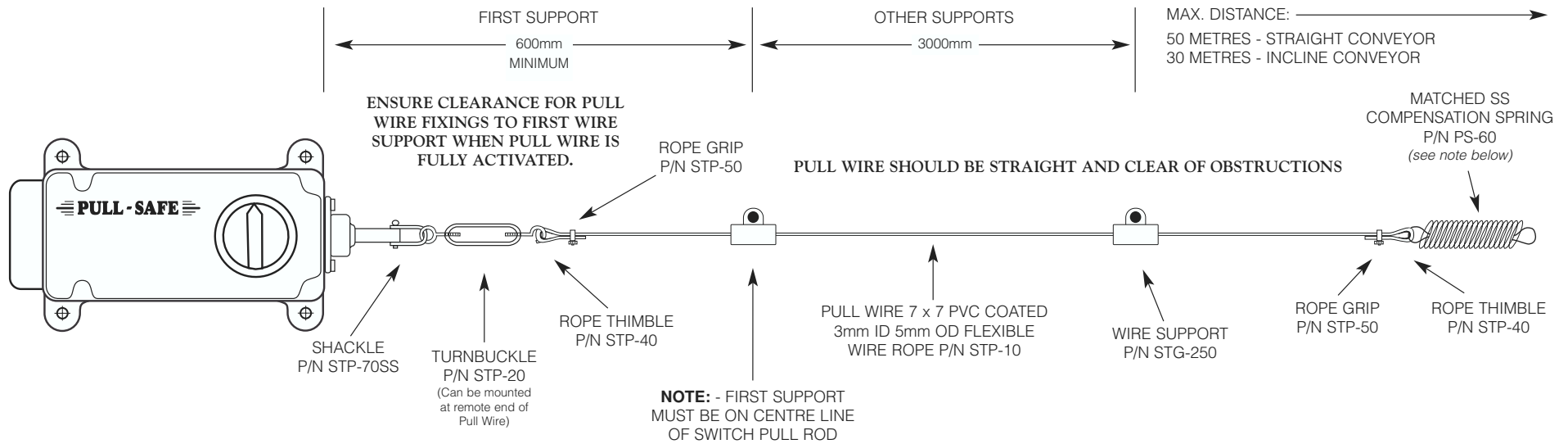

NOTE: - TO COMPLY WITH AS 4024 Parts 1 and 2  
A matched compensation spring must be fitted to the remote end of the Pull Wire to allow tripping in both directions.

SWITCH CANNOT BE RESET UNTIL PULL WIRE IS CORRECTLY TENSIONED  
ie. 75mm from pull rod end to switch body.

**Power Control**  
PRODUCTS

Unit 3, 8 Hayden Court, Myaree WA 6154  
Phone (08) 9317 4322, Fax (08) 9317 4465

PUB No. PS - INST. 03